

**Ministry of Transportation and
Communications**

**Taiwan New Car Assessment Program
(TNCAP)**

Second Version

3.6 Rear Whiplash Testing Protocol

V2.0
May 2024

TABLE OF CONTENTS

3.6.1 Definitions.....	3
3.6.2 Vehicle Setup	3
3.6.3 Test Procedure.....	5
3.6.4 Head Restraint Position Definitions.....	13
3.6.5 Discomfort Metric Measuring Device	16

3.6.1 Definitions

- 3.6.1.1 A-Surface: surface of a head restraint that is nearest to the occupant.
- 3.6.1.2 Discomfort Metric: A geometrical requirement in terms of size and location for shingled non-use position head restraint designs.
- 3.6.1.3 Non-use Position: A head restraint position at which the height does not comply with the minimum head restraint height requirements of the Vehicle Safety Testing Directions “50-2, Head Restraint” or UN-ECE Regulation 17-08.
- 3.6.1.4 Use Position: A head restraint position at which the height complies with the minimum head restraint height requirements of the Vehicle Safety Testing Directions “50-2, Head Restraint” or UN-ECE Regulation 17-08.
- 3.6.1.5 Highest Use Position: the highest locking use position. If a restraint has non-locking positions above the highest locking position, then the highest locking position is still considered as the highest position.
- 3.6.1.6 Lowest Use Position: the lowest locking or stowed use position i.e. the lowest locking or stowed position in which the head restraint still meets the minimum height requirements of the Vehicle Safety Testing Directions “50-2, Head Restraint” or UN-ECE Regulation 17-08.
- 3.6.1.7 Mid Use Position: the locking position at the geometric mid between the highest use position and the lowest use position, or the notch position closest to the geometric mid as determined by the method in 3.6.4.
- 3.6.1.8 Shingled Head Restraint: a non-use position design where the rear surface of the head restraint overlaps the seatback when the head restraint is adjusted to the non-use position.
- 3.6.1.9 C/LO: the centreline of a seating position, extending onto the top surface of the head restraint where applicable.
- 3.6.1.10 HLE: the distance from the R-point to the lower edge of the head restraint measured along the torso line.
- 3.6.1.11 S: is the maximum thickness of the head restraint (as determined within 25 mm of the head restraint lower edge) measured perpendicular to the torso line between TH and TS from line P.
- 3.6.1.12 P: is a line parallel to the torso line which intersects the head restraint at TS.
- 3.6.1.13 TH: is the line perpendicular to the torso line and tangent to the lower edge of the head restraint.
- 3.6.1.14 TS is the line parallel to and 25 mm from TH.

3.6.2 Vehicle Setup

Before assessment, the manufacturer will be asked to provide ride heights for the vehicle in the unladen kerb state. Ensure that the differences between ride-heights

are the same as those provided by the manufacturer. The absolute values of ride-heights do not matter.

Make sure the vehicle is stable by supporting the vehicle on the jacking points as shown in the vehicle hand book.

This protocol also extends to the first-row outboard seats only of heavy vehicles (as defined in section 1.4). In such cases, all intermediate seating positions of M1 category vehicles must be equipped with head restraints in order to earn points.

3.6.2.1 Vehicle Preparation

3.6.2.1.1 If the vehicle is equipped with a foldable roof, sunroof, sunroof blind, position to the closed position. Retract any rear glazing blinds.

3.6.2.1.2 Do not remove floor mats when fitted as standard.

3.6.2.1.3 Set all first row seats fully forward and into the highest position.

3.6.2.2 Second and Third Row Seating Setup

3.6.2.2.1 The manufacturer will be asked to provide seat adjustment information before the assessment is done (this information does not need to be in the vehicle handbook). Set all seat adjustments to the positions specified by the manufacturer.

3.6.2.2.2 Where the manufacturer has not provided seat adjustment specifications, or for particular adjustments where no specifications have been provided, set the seat using all or some of steps 3.6.2.2.2.1 through 3.6.2.2.2.14 (see also section 3.6.4 for details of how to set head restraint positions).

3.6.2.2.2.1 Seat Track – Set to the most rearward position intended for occupant use.

3.6.2.2.2.2 Seat Height – Set to the lowest position.

3.6.2.2.2.3 Seatback – Set to a position to give a nominal HPM torso angle of 25°. 20° in the case of vehicles categorized as ‘Heavy Vehicle’ (see section 1.4) protocol.

3.6.2.2.2.4 Seat Tilt – Set to a mid position.

3.6.2.2.2.5 Seat Cushion Height – Set to the lowest position.

3.6.2.2.2.6 Seat Cushion Tilt – Set to mid position.

3.6.2.2.2.7 Lumbar Support – Set to the retracted and lowest position.

3.6.2.2.2.8 Upper seat back – Set to the most rearward position.

3.6.2.2.2.9 Cushion Extension – Set to the retracted position.

3.6.2.2.2.10 Side Bolsters – Set to the retracted position on the seat base and seat back.

3.6.2.2.2.11 Head Restraint Vertical Position – Set to the lowest locking use position.

3.6.2.2.2.12 Head Restraint Horizontal Position – Set to mid position.

3.6.2.2.2.13 Head Restraint Tilt Position – Set to the mid position.

3.6.2.2.2.14 For third row assessment, set all second row seats into their fully forward and highest position if possible.

3.6.3 Test Procedure

If the seat to be assessed has never been sat upon, a person of mass 75 ± 10 kg shall sit on the seat two times for one minute to flex the seat cushion and seat back.

3.6.3.1 Determination of Seat Centerline C/LO

3.6.3.1.1 Refer to manufacturer specifications for the C/LO.

3.6.3.1.2 If manufacturer specifications are not available, find C/LO as follows:

3.6.3.1.2.1 For seats with defined bolsters, or individual auxiliary seats, C/LO is the centreline of the seat.

3.6.3.1.2.2 For bench seats (or other) seats, C/LO is the middle of the head restraint. If a head restraint is not fitted, find C/LO between the belt anchors.

3.6.3.1.2.3 If the C/LO cannot be found with the procedures 3.6.3.1.2.1 through 3.6.3.1.2.2 the C/LO is located 381mm outboard from the vehicle centreline.

3.6.3.2 H-Point Machine Installation

3.6.3.2.1 Place a piece of muslin cloth on the seat. Tuck the edge of the cloth into the seat pan/back join, but allow plenty of slack.

3.6.3.2.2 Place the seat and back assembly of the H-point machine on the seat at the centre line of the seat.

3.6.3.2.3 Apply thigh weights.

3.6.3.2.4 If it is possible to install the T bar and lower legs assemblies without interference with parts of the vehicle interior, this shall be done as described in the following subsections. However, if installation of the lower leg assemblies and/or the T bar causes interference with parts of the vehicle interior in a way that is likely to influence the position of the H point, do not install the legs and/or T bar. In this situation, every effort shall be made to ensure that the HPM does not slide forward on the seat base.

3.6.3.2.4.1 Attach the shoe and lower leg assemblies to the cushion pan assembly, individually at the knee joint or by using the T-bar lateral segment and lower leg assembly. Use 50th percentile lower leg segments and 50th percentile thigh segments.

3.6.3.2.4.2 The T-bar lateral segment shall be parallel to the Y-axis of the vehicle and perpendicular to the XZ-plane of the vehicle unless specified differently by the manufacturer.

- 3.6.3.2.4.3 Position both shoes together, or up to 127mm to either side of C/LO to clear obstructions.
 - 3.6.3.2.4.4 With both shoes touching the floor, extend both shoes forward of the HPM while keeping the T-Bar laterally leveled.
 - 3.6.3.2.4.5 Apply lower leg weights.
 - 3.6.3.2.5 Tilt the back pan forwards to the end stop and draw the machine away from the seatback.
 - 3.6.3.2.6 Allow the machine to slide back until it is stopped by contacting the seat back.
 - 3.6.3.2.7 Apply a $100 \pm 10\text{N}$ load twice to the back and pan assembly positioned at the intersection of the hip angle intersection to a point just above the thigh bar housing.
 - 3.6.3.2.8 Return the machine back to the seat back.
 - 3.6.3.2.9 Install the right and left buttock weights.
 - 3.6.3.2.10 Apply the torso weights alternately left and right.
 - 3.6.3.2.11 Tilting the back pan forward to a vertical position, the assembly shall be rocked from side to side over a 10° arc, 5° in each direction. Where seat side bolsters prevent movement of up to 5° , the assembly shall be rocked as far as permissible. This rocking shall be repeated twice, making a total of three complete cycles. Care shall be taken to maintain support of the T-bar during the rocking action, and to ensure that no inadvertent exterior loads are applied. Ensure that the movements of the HPM feet not restricted during this step. If the feet change position, they shall be allowed to remain in that attitude for the time being. Return the machine back to the seat back.
 - 3.6.3.2.12 Check the lateral spirit level and if necessary apply a lateral force to the top of the machine back, sufficient to level the seat pan of the machine.
 - 3.6.3.2.13 If applicable, position the shoes as described in 3.6.3.2.4.3 through 3.6.3.2.4.4
 - 3.6.3.2.14 Apply a rearward force not more than 25N at the top of the torso angle bar.
 - 3.6.3.2.15 Release the applied force and apply again until the hip angle readout shows identical values.
 - 3.6.3.2.16 Measure and record in the test details the position of the H-point relative to some easily identifiable part of the vehicle structure.
 - 3.6.3.2.17 Measure and record in the test details the angle of the seat assembly of the H-point machine and the position of the seat cushion front end.
- 3.6.3.3 HPM Measurement

All CMM measurements are relative to the manufacturer specified car alignment coordinate system or a suitable Cartesian coordinate system if not specified. Record all measurements to 0.1mm precision. For the purposes of this protocol the X-Axis is positive rearward and the Z-Axis is positive upward.

3.6.3.3.1 With a CMM or other means measure and record the X, Y and Z-coordinates for the left and right H-points.

3.6.3.3.2 Compare the left hand and right hand X and Z-coordinates. If the related X and Z coordinates are not within 5.0mm of each other repeat the H-point machine installation.

3.6.3.3.3 Measure and record the torso angle in the vehicle XZ-plane on the calibrated block attached to the weight hanger bar to 0.1 degree precision.

3.6.3.3.4 Repeat the H-point machine installation two more times.

3.6.3.3.5 Calculate the average for the three HPM installations measurements (HPM H-point coordinates and torso angle). Record these values.

3.6.3.3.6 If the average values recorded in 3.6.3.3.5 are within the following tolerances of the manufacturer specified values:

Torso angle: $\pm 3^\circ$

HPM X and Z: $\pm 25\text{mm}$

then the manufacturer-defined values shall be used in all subsequent calculations. Otherwise, the recorded average values shall be used.

3.6.3.4 Head Restraint Measurement

3.6.3.4.1 Contact point and backset

The distance between the head restraint and the back of the 50th percentile male head (backset) is determined at two head restraint positions: mid position and worst case (lowest and most rearward). The backset in the mid position is subsequently used in 3.6.3.4.2.1 as part of the determination of the intersection point (IP).

3.6.3.4.1.1 Mark a line showing the C/LO $\pm 5\text{mm}$ along the A-Surface of the head restraint.

3.6.3.4.1.2 Using the values of torso angle and H point determined in section 3.6.3.3, calculate the Contact Point Z-coordinate, CP Z, which represents the height of the rearmost point of the head of a 50th percentile male.

$$\text{CP Z} = 504.5 \cos(\text{Torso angle} - 2.6) + 203 + \text{HPM Z}$$

3.6.3.4.1.3 Set the head restraint to the mid position (see definitions and 3.6.4). For head restraints with locking tilt positions, it will be necessary to mark and measure CP with the restraint in the most forward and

most rearward positions in order to find its location and coordinates with the head restraint in the mid-tilt position (see also 3.6.4)

3.6.3.4.1.4 Use a CMM or other means to mark the CP Z-coordinate ($\pm 2.5\text{mm}$) on the C/LO line. This point is known as the Contact Point, CP.

3.6.3.4.1.4.1 If the CP Z-coordinate cannot be marked on the A-Surface of the head restraint (because the head restraint is below the CP Z-coordinate), record the CP Z-coordinate as the highest point on the C/LO line. If more than one point is at the highest point record the most forward point.

3.6.3.4.1.4.2 If the CP Z-coordinate cannot be marked on the A-Surface of the head restraint as the CP Z-coordinate relates to a gap in the head restraint, CP will be determined using a 165mm diameter sphere with its centre at the same height as the CP Z-coordinate. When the sphere is making first contact with the head restraint, CP is designated as the rearmost point of the sphere in the gap area (see Figure 1).

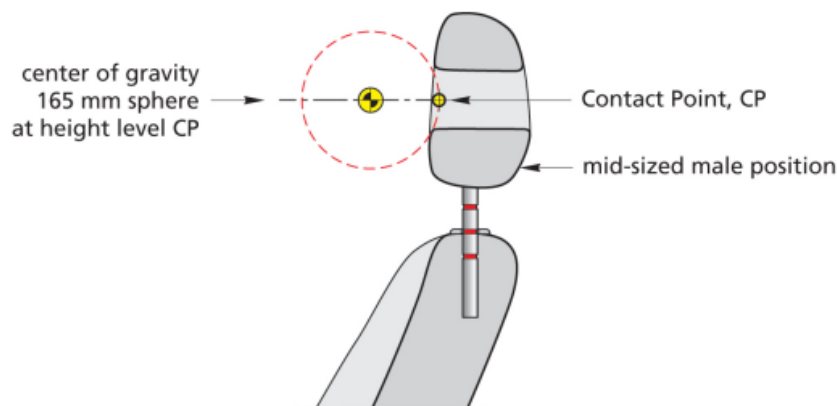

Figure 1 Definition of CP in the presence of a gap in the head restraint

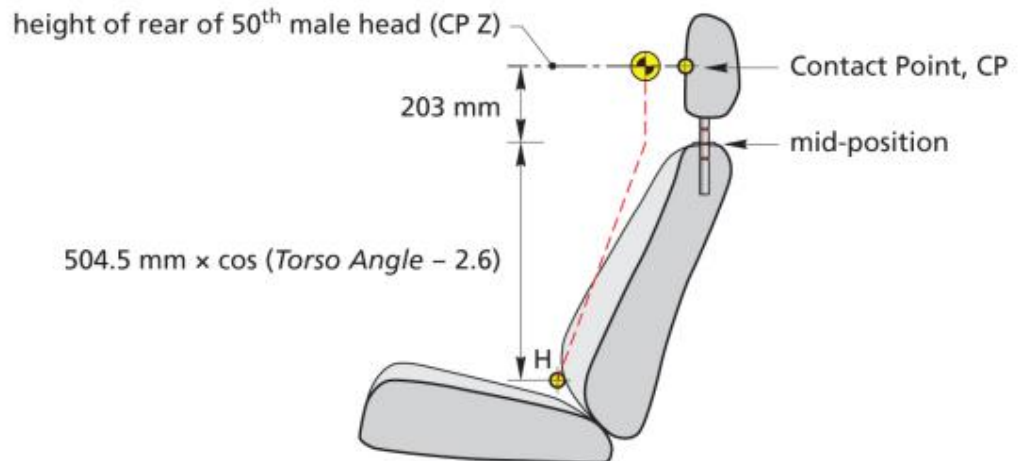

Figure 2 Contact point

3.6.3.4.1.5 Record the X-coordinate of the contact point. Record this as (CP X).

3.6.3.4.1.6 Calculate the CP X-coordinate relative to the HPM X-coordinate,

$(\Delta CP X)_{mid}$.

$$(\Delta CP X)_{mid} = CPX_{mid} - HPM X$$

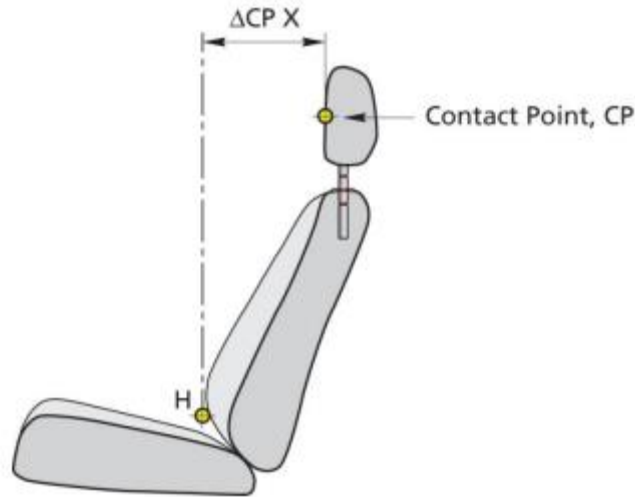

Figure 3 Calculation of backset

3.6.3.4.1.7 Set the head restraint to the lowest Use and most rearward position (see definitions and 3.6.4).

3.6.3.4.1.8 Repeat steps from sections 3.6.3.4.1.4 to 3.6.3.4.1.6 to calculate

$(\Delta CP X)_{wc}$

$$(\Delta CP X)_{wc} = CPX_{wc} - HPM X$$

3.6.3.4.2 Intersection Point (IP)

In this step, the ‘Intersection Point’ is established. To do this, the position of the contact point CP is extended rearward by a distance corresponding to the difference between the rearmost point of a 50th percentile male and a 95th percentile male. The point on the restraint corresponding to this X coordinate is marked as IP on the head restraint, when the restraint is in its highest position.

3.6.3.4.2.1 Calculate the Intersection Point X-coordinate, IP X, which represents the additional distance in X between the back of the head of a 50th percentile male and a 95th percentile male.

$$IP X = 88.5 \cdot \sin(Torso\ angle_{(3.6.3.3.5)-2.6}) + 5 + CPX_{(3.6.3.4.1.5)}$$

This formula derives from the subtraction of two goniometric formulae which, respectively, give the X position of the back of the head of a large male and that of a mid-sized male:

$$\begin{aligned} & (593 \cdot \sin(Torso\ angle - 2.6) + 76) - (504.5 \cdot \sin(Torso\ angle - 2.6) + 71) \\ & = 88.5 \cdot \sin(Torso\ angle - 2.6) + 5 \end{aligned}$$

3.6.3.4.2.2 Place the head restraint in the Highest Use and mid-tilt position (see definitions and 3.6.4).

3.6.3.4.2.3 On the surface given by the C/LO line, find the highest point and record the related X-coordinate.

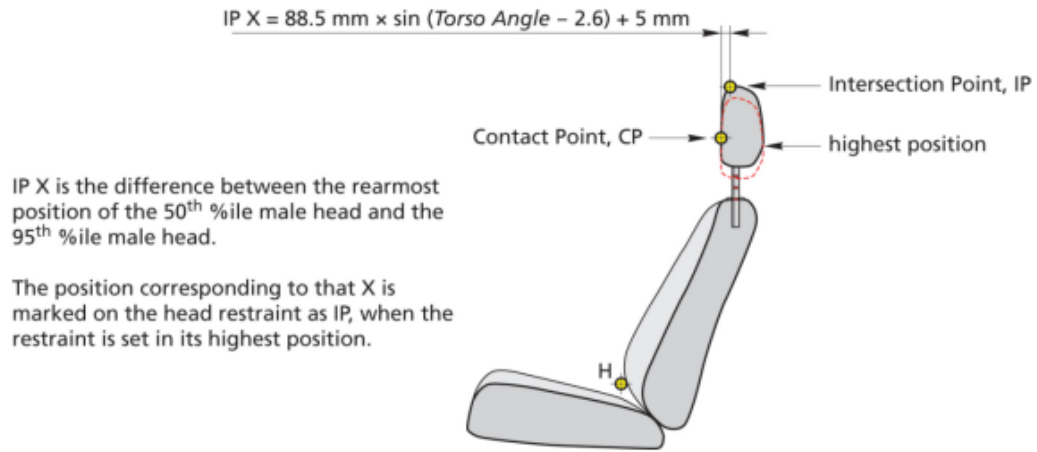

Figure 4 Intersection Point

3.6.3.4.2.4 Use a CMM or other means to mark the IP X-coordinate in 3.6.3.4.2.1 ($\pm 2.5\text{mm}$) on the C/LO line. If the IP X-coordinate is rearward of the X-coordinate value in 3.6.3.4.2.3, record the X-coordinate in 3.6.3.4.2.3 as IP X.

3.6.3.4.2.5 On the surface given by the C/LO line and the IP X point, record the Z-coordinate of the IP X mark (3.6.3.4.2.4). Record this point as Intersection Point Z (IP Z).

3.6.3.4.2.6 Calculate the IP X-coordinate relative to the HPM X-coordinate, $(\Delta IP\ X)_{high}$.

$$(\Delta IP\ X)_{high} = IP\ X - HPM\ X$$

3.6.3.4.2.7 Calculate the IP Z-coordinate relative to the HPM Z-coordinate, $(\Delta IP\ Z)_{high}$.

$$(\Delta IP\ Z)_{high} = IP\ Z - HPM\ Z$$

3.6.3.4.2.8 Place the head restraint in the Lowest Use and most rearward position (see definitions and 3.6.4).

3.6.3.4.2.9 Using the same method as above, calculate $\Delta IP\ X$ and $\Delta IP\ Z$ for this head restraint position and record as $(\Delta IP\ X)_{wc}$ and $(\Delta IP\ Z)_{wc}$.

3.6.3.4.3 Effective height

The effective height of the Intersection Point is determined in the highest and in the worst-case (lowest and most rearward) head restraint positions.

3.6.3.4.3.1 Calculate the Effective Height for the highest and for the worst-case (lowest, most rearward) in-use positions, using the appropriate

values determined in sections 3.6.3.4.2.6 to 3.6.3.4.2.9.

$$\text{Effective height} = (\Delta\text{IP } X)\sin(\text{torso angle}) + (\Delta\text{IP } Z)\cos(\text{torso angle})$$

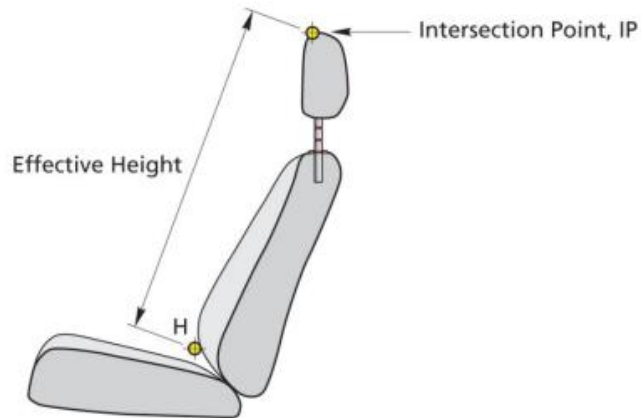

Figure 5 Effective Height

3.6.3.4.3.2 Record the values as (Effective Height)_{high} and (Effective Height)_{WC}.

3.6.3.5 Non-use Position Measurement

The non-use position assessment does not apply to the first-row seats in heavy-duty vehicles according to section 1.4.

3.6.3.5.1 Automatic return head restraints

3.6.3.5.1.1 Weight-based systems

3.6.3.5.1.1.1 Set the head restraint in the non-use position

3.6.3.5.1.1.2 Position a Hybrid III 5th percentile adult female dummy in the seat aligned with the CL/O and parallel to the XZ-plane.

3.6.3.5.1.1.3 Hold the dummy's thighs down and push rearward on the upper torso to maximize the dummy's pelvic angle.

3.6.3.5.1.1.4 Place the tibias as near to 90° to the thighs as possible. Push rearward on the dummy's knees to force the pelvis into the seat so there is no gap between the pelvis and the seat back or until the back of the dummy's calves touch the front of the seat cushion.

3.6.3.5.1.1.5 Start the vehicle engine. Record whether or not the head restraint moves to a use position.

3.6.3.5.1.2 Capacitance-based systems

3.6.3.5.1.2.1 Set the head restraint to the non-use position.

3.6.3.5.1.2.2 Turn on the ignition or start the vehicle engine.

3.6.3.5.1.2.3 Sit a person weighing 75±10kg in the seat.

3.6.3.5.1.2.4 Record whether or not the head restraint moves to a use position.

3.6.3.5.1.2.5 Repeat 3.6.3.5.1.2.3 and 3.6.3.5.1.2.4 in different types of

clothing (light summer clothing; thick, padded winter clothing)
to ensure repeatable operation of the automatic return system.

3.6.3.5.2 60° Rotation Evaluation

3.6.3.5.2.1 Set the head restraint in the lowest use locking position.

3.6.3.5.2.2 Position a digital inclinometer (which can measure to a precision of 0.1°) on a suitable surface of the head restraint. Record the angle measurement.

3.6.3.5.2.3 Fold or retract the head restraint forwards to the non-use position and record the angle again.

3.6.3.5.2.4 Subtract the angle recorded in 3.6.3.5.2.3 from the angle recorded in 3.6.3.5.2.2.

3.6.3.5.3 10° Torso Line Change

3.6.3.5.3.1 Set the head restraint into the non-use position.

3.6.3.5.3.2 Install the HPM following procedures in 3.6.3.2.1 to 3.6.3.2.17 and record the torso angle.

3.6.3.5.3.3 Subtract the torso angle measured in 3.6.3.5.3.2 from the torso angle measured in 3.6.3.3.3 and record the value.

3.6.3.5.4 Discomfort metric

3.6.3.5.4.1 Set the head restraint into the non-use position.

3.6.3.5.4.2 On the surface given by the C/LO line, find the lowest point on the head restraint (T_H) and record the related X-coordinate and Z-coordinate.

3.6.3.5.4.3 Calculate the X-coordinate recorded in 3.6.3.5.4.2 relative to the HPM X-coordinate, (ΔX).

$$\Delta X = X_{3.6.3.5.4.2} - \text{HPM X}$$

3.6.3.5.4.4 Calculate the Z-coordinate recorded in 3.6.3.5.4.2 relative to the HPM Z-coordinate, (ΔZ).

$$\Delta Z = Z_{3.6.3.5.4.2} - \text{HPM Z}$$

3.6.3.5.4.5 Calculate the H_{LE} (Height of the lowest point (T_H) on the head restraint relative to the HPM H-point) using:

$$H_{LE} = \Delta X \cdot \sin(\text{torso angle}) + \Delta Z \cdot \cos(\text{torso angle})$$

3.6.3.5.4.6 Using the measuring device in 3.6.5 determine the thickness(S).

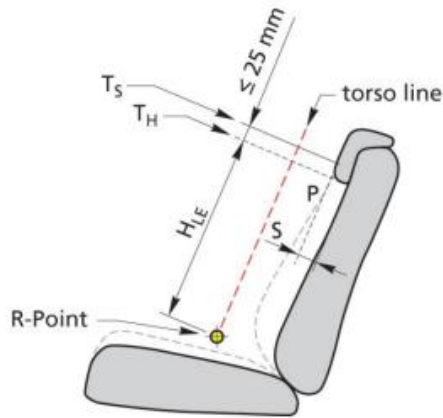

Figure 6 Discomfort metric geometric requirements

3.6.4 Head Restraint Position Definitions

The protocol refers to several head restraint positions – highest, lowest, mid, most rearward etc. This section defines how to establish these positions of the restraint.

3.6.4.1 Vertical Adjustments

3.6.4.1.1 Highest Use Position

3.6.4.1.1.1 The highest position is considered to be the highest locking position.

If a restraint has a non- locking position above the highest locking position, then the highest locking position is still considered as the highest position.

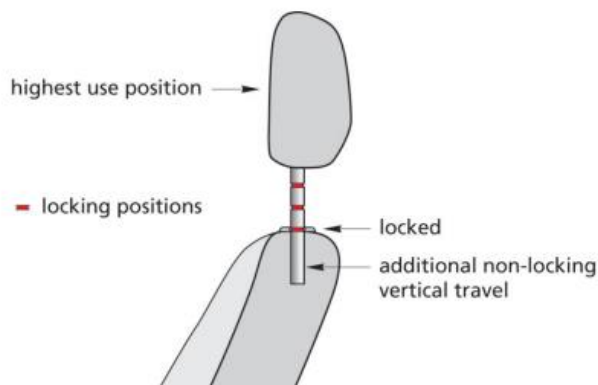

Figure 7 Highest Use Position

3.6.4.1.2 Lowest Use Position

3.6.4.1.2.1 The lowest in-use position is considered to be the lowest locking or stowed position in which the restraint meets the minimum height requirements specified in the Vehicle Safety Testing Directions “50-2, Head Restraint” or in UN R17-08. See Figure 8.

3.6.4.1.3 Mid Position

3.6.4.1.3.1 Mark a repeatable reference point on the top of the head restraint. This point is typically the highest point on the centreline of the head

restraint.

3.6.4.1.3.2 Place the head restraint in the lowest Use position as defined in 3.6.4.1.2.

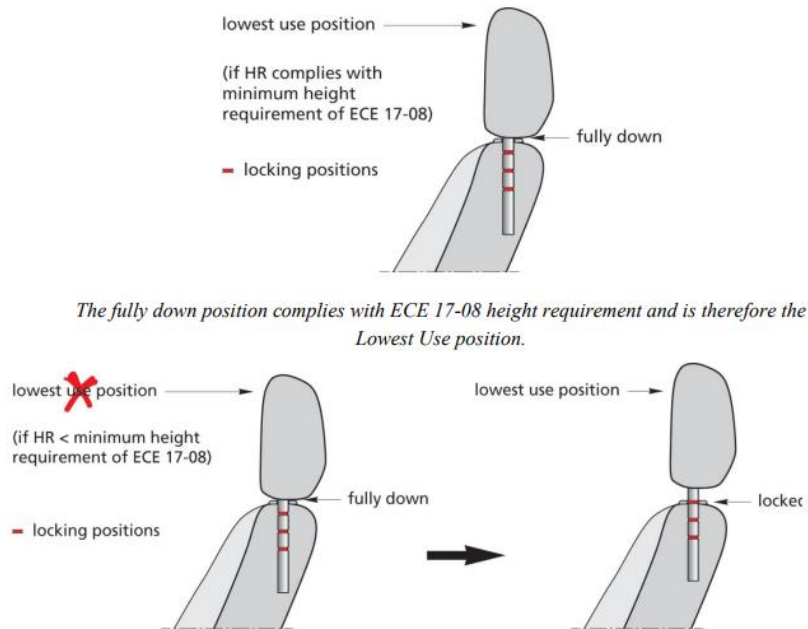

Figure 8 Examples of setting lowest use position

3.6.4.1.3.3 Using a coordinate measurement device, measure the reference point in the Lowest Use position as defined in 3.6.4.1.3.2, and then in the Highest Use position (section 3.6.4.1.1) without altering tilt or any other seat settings.

3.6.4.1.3.4 Midrange height position is determined by calculating the geometric mid point between the lowest position, and highest locking vertical adjustments, considering only the vertical component of measurement. The test position will then be selected based on the following conditions:

3.6.4.1.3.5 Place the head restraint at the geometric mid point if a locking position exists there.

3.6.4.1.3.6 If there is no locking position at the geometric mid point, raise the head restraint by up to 10mm. If a locking position exists within this 10mm of travel, that position will be the test position.

3.6.4.1.3.7 If there is no locking position within 10mm above the geometric mid point, lower the head restraint to the next lowest locking position.

3.6.4.1.3.8 If there is no locking position before the lowest or stowed position is reached, then the head restraint shall be positioned fully down. This will only be the case if the head restraint complies with the

height requirements specified in the Vehicle Safety Testing Directions “50-2, Head Restraint” or in UN R17-08 in the fully down position (i.e. fully down is the Lowest Use position)

3.6.4.1.3.9 Once the vertical test position has been determined, ensure the head restraint is returned to rearmost tilt position.

3.6.4.1.4 Examples of Single Notch Head Restraint

(1) Lowest/stowed position meets the height requirements specified in the Vehicle Safety Testing Directions “50-2, Head Restraint” or in UN R17-08.

(A) The highest use position is at the locking notch.

(B) In the fully lowered/stowed position, the head restraint complies with the height requirements specified in the Vehicle Safety Testing Directions “50-2, Head Restraint” or in UN R17-08. Therefore, this position is the lowest use position.

(C) There is no notch at the geometric mid between Highest Use and Lowest Use positions.

(D) The method of 3.6.4.1.3.6 is followed: if the notch is within 10mm upward of the geometric mid, the notch position becomes the Mid Position (as well as being the Highest Use position); otherwise the Mid Position becomes the fully lowered/stowed position.

(2) The lowest/stowed position does not meet the height requirements specified in the Vehicle Safety Testing Directions “50-2, Head Restraint” or in UN R17-08.

(A) The highest use position is at the locking notch.

(B) In the fully lowered/stowed position, the head restraint does not comply with the height requirements specified in the Vehicle Safety Testing Directions “50-2, Head Restraint” or in UN R17-08. If the head restraint's first locking position complies with the requirements specified in the Vehicle Safety Testing Directions “50-2, Head Restraint” or in UN R17-08. The notch position therefore becomes the Lowest Use position.

(C) The notch position is both the Highest Use and Lowest Use positions.

(D) The notch position also becomes the Mid Position.

3.6.4.2 Tilt Adjustment

3.6.4.2.1 The following procedure shall be used for locking horizontal adjustments only. For non-locking tilt adjustments, the head restraint shall always be tilted fully rearward.

3.6.4.2.1.1 Most rearward tilt position shall be that which results in greatest backset measurement of the Contact Point CP. In the situation where

the head restraint cannot be placed at most rearward tilt (e.g. due to a return spring), the most “most rearward tilt” shall be the most rearward position in which the tilt can be locked.

3.6.4.2.1.2 Most forward tilt position shall be that which results in the smallest backset measurement of the Contact Point CP. It shall be determined by finding the most forward locking tilt position. Non-locking positions located further forward than the most forward lock are disregarded.

3.6.4.2.1.3 Midrange tilt position is determined by calculating the geometric mid point between the most rearward tilt and most forward locking horizontal adjustments, considering the backsets measured. Midrange tilt setting shall be undertaken using the same rationale as used in 3.6.4.1.3. A locking position shall be sought within a window 10mm forwards from the geometric mid point. If a lock is found within this window, that position shall be considered the test position. In the absence of a lock within this range the head restraint shall be moved rearwards until the next locking position is reached. If no locking positions are reached before the fully rearward tilt position, then fully rearward tilt shall be the position used.

3.6.5 Discomfort Metric Measuring Device

Example of a pass/fail gauge to be used with an inclinometer to examine if a shingled head restraint in the non-use position meets the thickness requirement (S), at a height of 25mm above the lowest point on the head restraint along the torso angle line.

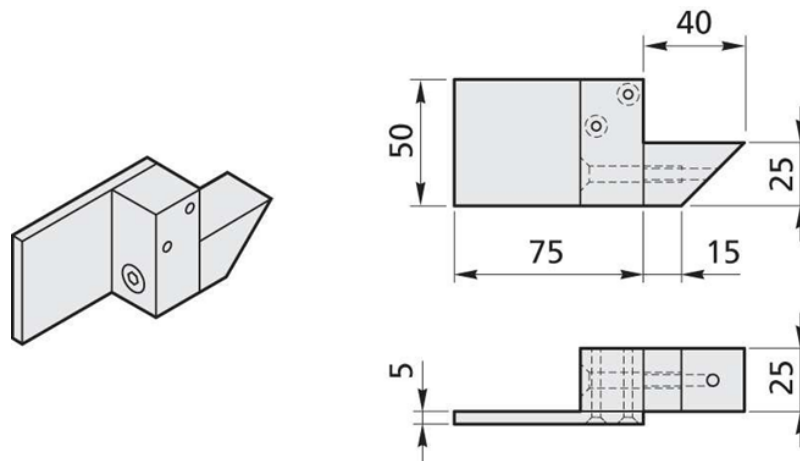

Figure 9 Discomfort metric gauge design example (all dimension in mm)

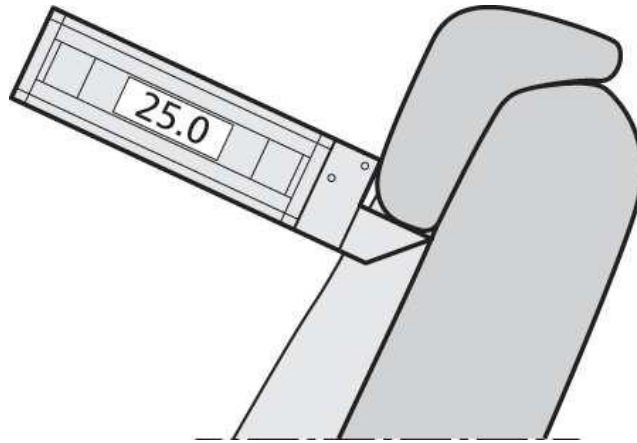

Figure 10 Using the gauge with an inclinometer