

**Ministry of Transportation and  
Communications**

**Taiwan New Car Assessment Program  
(TNCAP)**

**Second Version**

**3.11 AEB VRU Testing Protocol**

V2.1  
Nov 2025

## TABLE OF CONTENTS

3.11.1 Definitions.....	3
3.11.2 Reference System.....	6
3.11.3 Measuring Equipment.....	8
3.11.4 Euro NCAP Pedestrian and Bicyclist Target .....	9
3.11.5 Test Conditions .....	10
3.11.6 Test Procedure .....	14
3.11.7 Obstruction Dimensions.....	20
3.11.8 Testing at Low Ambient Lighting Conditions .....	21

### 3.11.1 Definitions

- 3.11.1.1 Peak Braking Coefficient (PBC): The measure of tire to road surface friction based on the maximum deceleration of a rolling tire, measured using the American Society for Testing and Materials (ASTM) F2493-20 standard reference test tire, in accordance with ASTM Method E1337-19, at a speed of 64.4km/h, without water delivery, or methods specified in the Vehicle Safety Testing Directions 43-2, Section 6.2.5.1.
- 3.11.1.2 Autonomous Emergency Braking (AEB): A braking system that is applied automatically by the vehicle in response to the detection of a likely collision to reduce the vehicle speed and potentially avoid the collision.
- 3.11.1.3 Forward Collision Warning (FCW): An audiovisual warning that is provided automatically by the vehicle in response to the detection of a likely collision to alert the driver.
- 3.11.1.4 Vehicle Width: The widest point of the vehicle ignoring the rear-view mirrors, side marker lamps, tire pressure indicators, direction indicator lamps, position lamps, flexible mud-guards and the deflected part of the tire side-walls immediately above the point of contact with the ground.
- 3.11.1.5 Car-to-Pedestrian Farside Adult 50% (CPFA-50): A collision in which a vehicle travels forwards towards an adult pedestrian crossing its path running from the farside and the frontal structure of the vehicle strikes the pedestrian at 50% of the vehicle's width when no braking action is applied.
- 3.11.1.6 Car-to-Pedestrian Nearside Adult 25% (CPNA-25): A collision in which a vehicle travels forwards towards an adult pedestrian crossing its path walking from the nearside and the frontal structure of the vehicle strikes the pedestrian at 25% of the vehicle's width when no braking action is applied.
- 3.11.1.7 Car-to-Pedestrian Nearside Adult 75% (CPNA-75): A collision in which a vehicle travels forwards towards an adult pedestrian crossing its path walking from the nearside and the frontal structure of the vehicle strikes the pedestrian at 75% of the vehicle's width when no braking action is applied.
- 3.11.1.8 Car-to-Pedestrian Nearside Child 50% (CPNC-50): A collision in which a vehicle travels forwards towards a child pedestrian crossing its path running from behind and obstruction from the nearside and the frontal structure of the vehicle strikes the pedestrian at 50% of the vehicle's width when no braking action is applied.
- 3.11.1.9 Car-to-Pedestrian Longitudinal Adult 25% (CPLA-25): A collision in which a vehicle travels forwards towards an adult pedestrian walking in the same

direction in front of the vehicle where the vehicle strikes the pedestrian at 25% of the vehicle's width when no braking action is applied or an evasive steering action is initiated after an FCW.

- 3.11.1.10 Car-to-Pedestrian Longitudinal Adult 50% (CPLA-50): A collision in which a vehicle travels forwards towards an adult pedestrian walking in the same direction in front of the vehicle where the vehicle strikes the pedestrian at 50% of the vehicle's width when no braking action is applied.
- 3.11.1.11 Car-to-Bicyclist Nearside Adult 50% (CBNA-50): A collision in which a vehicle travels forwards towards a bicyclist crossing its path cycling from the nearside and the frontal structure of the vehicle strikes the bicyclist when no braking action is applied.
- 3.11.1.12 Car-to-Bicyclist Longitudinal Adult 25% (CBLA-25): A collision in which a vehicle travels forwards towards a bicyclist cycling in the same direction in front of the vehicle where the vehicle would strike the cyclist at 25% of the vehicle's width when no braking action is applied or an evasive steering action is initiated after an FCW.
- 3.11.1.13 Car-to-Bicyclist Longitudinal Adult 50% (CBLA-50): A collision in which a vehicle travels forwards towards a bicyclist cycling in the same direction in front of the vehicle where the vehicle would strike the cyclist at 50% of the vehicle's width when no braking action is applied.
- 3.11.1.14 Vehicle Under Test (VUT): Means the vehicle tested according to this protocol with a pre-crash collision mitigation or avoidance system on board.
- 3.11.1.15 Euro NCAP Pedestrian Target (EPTa): Means the adult pedestrian target used in this protocol as specified in the Articulated Pedestrian Target Specification document version 2.0.
- 3.11.1.16 Euro NCAP Child Target (EPTc): Means the child pedestrian target used in this protocol as specified in the Articulated Pedestrian Target Specification document version 2.0.
- 3.11.1.17 Euro NCAP Bicyclist Target (EBT): Means the bicyclist and bike target used in this protocol as specified in the Bicyclist Target Specification document version 1.0.
- 3.11.1.18 Time To Collision (TTC): Means the remaining time before the VUT strikes the EPT, assuming that the VUT and EPT would continue to travel with the speed it is travelling.
- 3.11.1.19 Time of Autonomous Emergency Braking ( $T_{AEB}$ ) Activation: Means the time where the AEB system activates. Activation time is determined by identifying the last data point where the filtered acceleration signal is below  $-1 \text{ m/s}^2$ , and then going back to the point in time where the acceleration

first crossed  $-0.3 \text{ m/s}^2$ .

3.11.1.20 Time of Forward Collision Warning ( $T_{FCW}$ ) Activation: Means the time where the audible warning of the FCW starts. The starting point is determined by audible recognition.

3.11.1.21 Impact Speed ( $V_{\text{impact}}$ ): Means the speed at which the profiled line around the front end of the VUT coincides with the square box around the EPTa, EPTc and EBT as shown in the figure below.

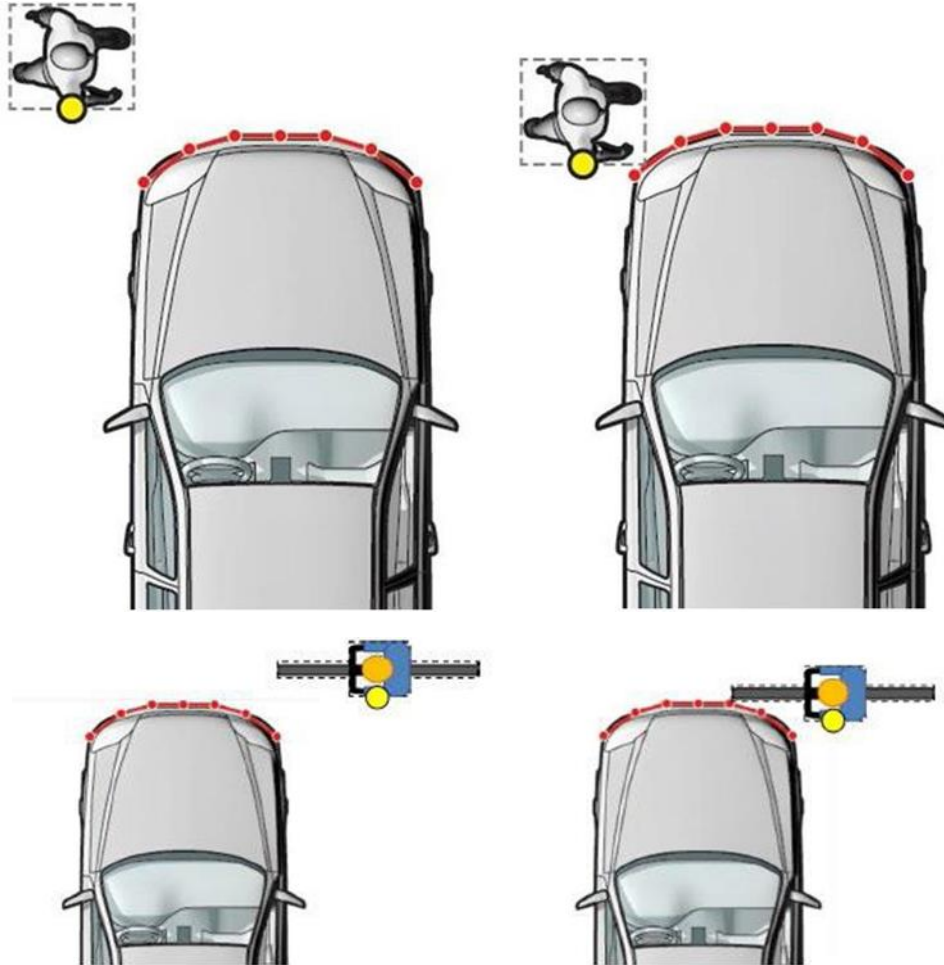

## 3.11.2 Reference System

### 3.11.2.1 Convention

3.11.2.1.1 For VUT, EPT and EBT use the convention specified in ISO 8855:1991 in which the x-axis points towards the front of the vehicle, the y-axis towards the left and the z-axis upwards (right hand system), with the origin at the most forward point on the centreline of the VUT for dynamic data measurements as shown in Figure 1.

3.11.2.1.2 Viewed from the origin, roll, pitch and yaw rotate clockwise around the x, y and z axes respectively. Longitudinal refers to the component of the measurement along the x-axis, lateral the component along the y-axis and vertical the component along the z-axis.

3.11.2.1.3 The nearside is swapped as per LHD and RHD vehicles. Figure 1 shows the near and farside of the vehicle for a left hand driven (LHD) vehicle.

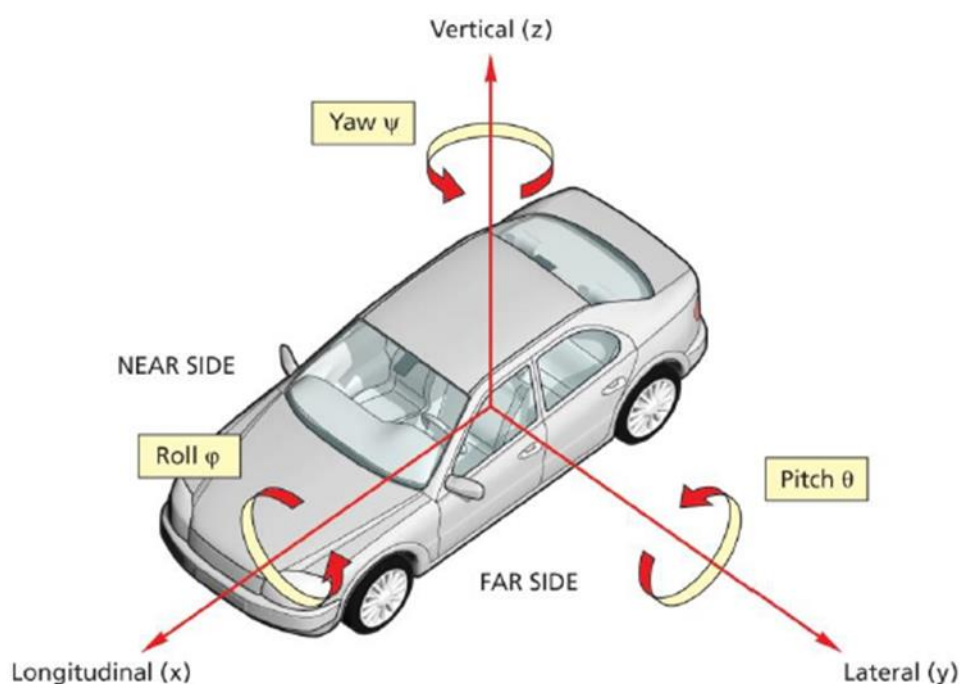

Figure 1: Coordinate system and notation

### 3.11.2.2 Lateral Path Error

3.11.2.2.1 The lateral offset is determined as the lateral distance between the centre of the front of the VUT when measured in parallel to the intended straight lined path as shown in the figure below.

$$\text{Lateral offset} = Y_{\text{VUT error}}$$

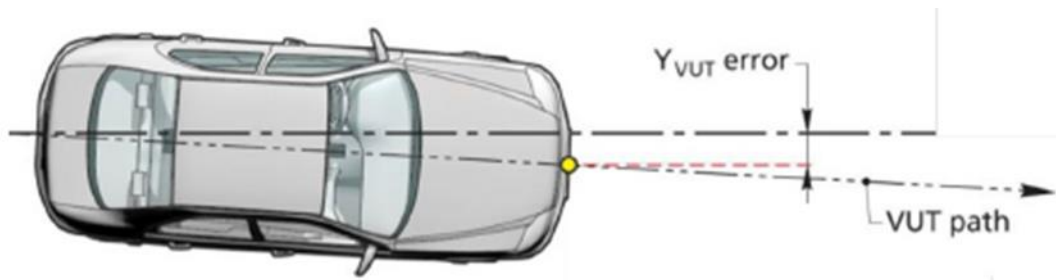

Figure 2: Lateral path error

### 3.11.2.3 Profiles for impact speed determination

3.11.2.3.1 A virtual profiled line is defined around the front end of the VUT. This line is defined by straight line segments connecting seven points that are equally distributed over the vehicle width minus 50mm on each side. The theoretical x,y coordinates are provided by the OEMs and verified by the technical service.

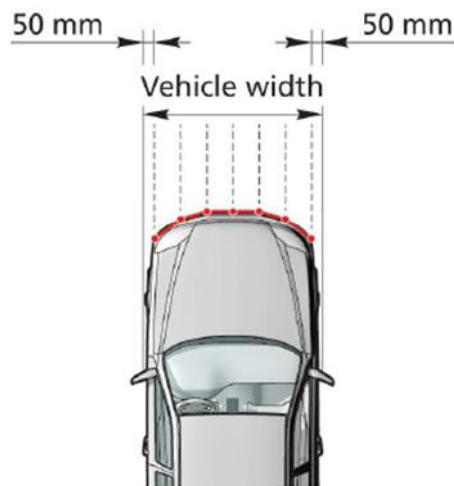

Figure 3: Virtual profiled line around vehicle front end

3.11.2.3.2 Around the EPT a virtual box is defined which is used to determine the impact speed. The dimensions of this virtual box are shown in Figure 4 below. For crossing scenarios, the reference point of the EPT is the HIP point and for the longitudinal scenario a virtual point where the centreline of the dummy crosses the virtual box.



Figure 4: Virtual box dimensions around EPTa and EPTc

3.11.2.3.3 Around the EBT a virtual box is defined which is used to determine the impact speed. The dimensions of this virtual box are shown in Figure 5 below. For crossing scenarios, the reference point of the EBT is the centre of the bottom bracket (crank shaft) (dashed line in Figure 5) and for the longitudinal scenario the most rearward point on the rear wheel is used.

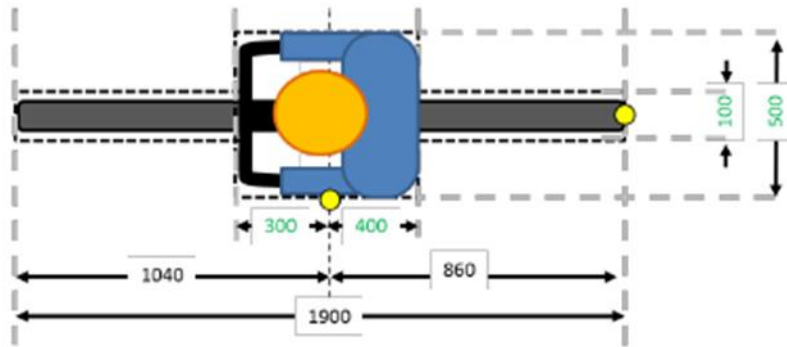

Figure 5: Virtual box dimensions around EBT

### 3.11.3 Measuring Equipment

3.11.3.1 Sample and record all dynamic data at a frequency of at least 100Hz. Synchronize using the DGPS time stamp the EPT and EBT data with that of the VUT.

#### 3.11.3.2 Measurements and Variables

##### 3.11.3.2.1 Time

- |  |           |
|--|-----------|
| (1) $T_0$ equals TTC = 4s                            | T         |
| (2) $T_{AEB}$ , time where AEB activates             | $T_0$     |
| (3) $T_{FCW}$ , time where FCW activates             | $T_{AEB}$ |
| (4) $T_{impact}$ , time where VUT impacts EPT or EBT | $T_{FCW}$ |

##### 3.11.3.2.2 Position of the VUT during the entire test

$T_{impact}$

##### 3.11.3.2.3 Position of the EPT or EBT during the entire test

- |                                |                    |
|--------------------------------|--------------------|
| (1) For crossing scenarios     | $X_{VUT}, Y_{VUT}$ |
| (2) For longitudinal scenarios | $Y_{EPT}/Y_{EBT}$  |

##### 3.11.3.2.4 Speed of the VUT during the entire test

$X_{EPT}/X_{EBT}$

- |  |           |
|--|-----------|
| (1) $V_{impact}$ , speed when VUT impacts EPT or EBT | $V_{VUT}$ |
|--|-----------|

##### 3.11.3.2.5 Speed of the EPT or EBT during the entire test

$V_{impact}$

##### 3.11.3.2.6 Yaw velocity of the VUT during the entire test

$V_{EPT}/V_{EBT}$

##### 3.11.3.2.7 Longitudinal acceleration of the VUT during the entire test

$\Psi_{VUT}$

##### 3.11.3.2.8 Steering wheel velocity of the VUT during the entire test

$A_{VUT}$

### 3.11.3.3 Measuring Equipment

3.11.3.3.1 Equip the VUT, EPT and EBT with data measurement and acquisition equipment to sample and record data with an accuracy of at least:

- (1) VUT speed: 0.1km/h
- (2) EPT and EBT speed: 0.01km/h
- (3) VUT lateral and longitudinal position: 0.03m
- (4) EPT and EBT position in the direction of movement: 0.03m
- (5) VUT yaw rate: 0.1°/s
- (6) VUT longitudinal acceleration: 0.1m/s<sup>2</sup>
- (7) VUT steering wheel velocity: 1.0 °/s

#### 3.11.3.4 Data Filtering

3.11.3.4.1 Filter the measured data as follows:

- 3.11.3.4.1.1 Position and speed are not filtered and are used in their raw state.
- 3.11.3.4.1.2 Acceleration, yaw rate and VUT steering wheel velocity with a 12-pole phaseless Butterworth filter with a cut off frequency of 10Hz.

#### 3.11.4 Euro NCAP Pedestrian and Bicyclist Target

##### 3.11.4.1 Specification

3.11.4.1.1 Conduct the tests in this protocol using the Euro NCAP Pedestrian Target (EPTa and EPTc) and Euro NCAP Bicyclist and bike Target (EBT) dressed in a black shirt and blue trousers, as shown in Figure 6 below. The EPT and EBT replicate the visual, radar, LIDAR and PMD attributes of a typical pedestrian and bicyclist respectively, and is impacted without causing significant damage to the VUT.



Figure 6: Euro NCAP Pedestrian and Bicyclist and bike Targets (EPTa, EPTc and EBT)

3.11.4.1.2 To ensure repeatable results the propulsion system, EPT and EBT must meet the requirements as detailed in Articulated Pedestrian Target Specification document version 2.0 and Bicyclist Target Specification document version 1.0.

3.11.4.1.3 The EPT and EBT are designed to work with the following types of sensors:

- (1) Radar (24 and 77 GHz)
- (2) LIDAR

### (3) Camera

When a manufacturer believes that the EPT or EBT is not suitable for another type of sensor system used by the VUT but not listed above, the manufacturer is asked to contact TNCAP executive agency.

## 3.11.5 Test Conditions

### 3.11.5.1 Test Track

3.11.5.1.1 Conduct tests on a dry (no visible moisture on the surface), uniform, solid-paved surface with a consistent slope between level and 1%. The test surface shall have a minimal peak braking coefficient (PBC) of 0.9.

3.11.5.1.2 The surface must be paved and may not contain any irregularities (e.g. large dips or cracks, manhole covers or reflective studs) that may give rise to abnormal sensor measurements within a lateral distance of 3.0m to either side of the test path and with a longitudinal distance of 30m ahead of the VUT when the test ends.

3.11.5.1.3 The presence of lane markings is allowed. However, testing may only be conducted in an area where typical road markings depicting a driving lane may not be parallel to the test path within 3.0m either side. Lines or markings may cross the test path, but may not be present in the area where AEB activation and/or braking after FCW is expected.

### 3.11.5.2 Weather Conditions

3.11.5.2.1 Conduct tests in dry conditions with ambient temperature above 5°C and below 40°C. For night time tests, the lab may liaise with the OEM to be able to test at lower temperatures.

3.11.5.2.2 No precipitation shall be falling and horizontal visibility at ground level shall be greater than 1km. Wind speeds shall be below 10m/s to minimize EPT, EBT and VUT disturbance. In case of wind speeds above 5m/s during test the validity of the tests is decided by lab discretion using the OEM predicted performance.

3.11.5.2.3 For daytime testing, natural ambient illumination must be homogenous in the test area and in excess of 2000 lux for daylight testing with no strong shadows cast across the test area other than those caused by the VUT, EPT or EBT. Ensure testing is not performed driving towards, or away from the sun when there is direct sunlight.

3.11.5.2.4 Testing at low ambient lighting conditions, nighttime, are specified in section 3.11.8.

3.11.5.2.5 Measure and record the following parameters preferably at the commencement of every single test or at least every 30 minutes:

(1) Ambient temperature in °C;

- (2) Track temperature in °C;
- (3) Wind speed and direction in m/s;
- (4) Ambient illumination in lux.

### 3.11.5.3 Surroundings

3.11.5.3.1 Conduct testing such that there are no other vehicles, highway infrastructure (except lighting columns during the low ambient lighting condition tests), obstructions, other objects or persons protruding above the test surface that may give rise to abnormal sensor measurements within a minimum lateral distance of the VUT test path as per table below (for a LHD vehicle), 1.0m around of the EPT and EBT and within a longitudinal distance of 30m ahead of the VUT when the test ends (Figure 7).



Figure 7: Free surroundings

3.11.5.3.2 Test areas where the VUT needs to pass under overhead signs, bridges, gantries or other significant structures are not permitted.

3.11.5.3.3 The general view ahead and to either side of the test area shall comprise of a wholly plain man made or natural environment (e.g. further test surface, plain colored fencing or hoardings, natural vegetation or sky etc.) and must not comprise any highly reflective surfaces or contain any vehicle-like silhouettes that may give rise to abnormal sensor measurements.

### 3.11.5.4 VUT Preparation

3.11.5.4.1 AEB and FCW System Settings

3.11.5.4.1.1 Set any driver configurable elements of the AEB and/or FCW system (e.g. the timing of the collision warning or the braking application if present) to the middle setting or midpoint and then next latest setting similar to the examples shown in Figure 8.

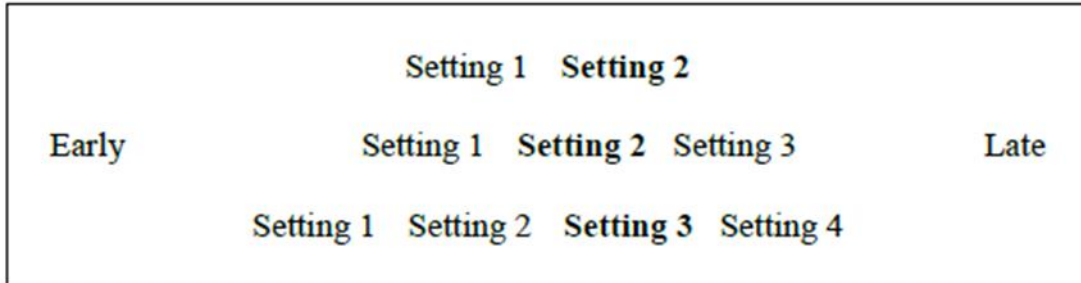

Figure 8: AEB and/or FCW system setting for testing

#### 3.11.5.4.2 Deployable Pedestrian/VRU Protection Systems

When the vehicle is equipped with a deployable pedestrian/VRU protection system, this system shall be deactivated before the testing commences.

#### 3.11.5.4.3 Tires

Perform the testing with new original fitment tires of the make, model, size, speed and load rating as specified by the vehicle manufacturer. It is permitted to change the tires which are supplied by the manufacturer or acquired at an official dealer representing the manufacturer if those tires are identical make, model, size, speed and load rating to the original fitment. Use inflation pressures corresponding to least loading normal condition.

Run-in tires according to the tire conditioning procedure specified in 3.11.6.1.3. After running-in maintain the run-in tires in the same position on the vehicle for the duration of the testing.

#### 3.11.5.4.4 Wheel Alignment Measurement

The vehicle shall be subject to a vehicle (in-line) geometry check to record the wheel alignment set by the OEM. This shall be done with the vehicle in kerb weight.

#### 3.11.5.4.5 Unladen Kerb Mass

3.11.5.4.5.1 Fill up the tank with fuel to at least 90% of the tank's capacity of fuel.

3.11.5.4.5.2 Check the oil level and top up to its maximum level if necessary. Similarly, top up the levels of all other fluids to their maximum levels if necessary.

3.11.5.4.5.3 Ensure that the vehicle has its spare wheel on board, if fitted, along

with any tools supplied with the vehicle. Nothing else shall be in the car.

3.11.5.4.5.4 Ensure that all tires are inflated according to the manufacturer's instructions for the least loading condition.

3.11.5.4.5.5 Measure the front and rear axle masses and determine the total mass of the vehicle. The total mass is the 'unladen kerb mass' of the vehicle. Record this mass in the test details.

3.11.5.4.5.6 Calculate the required ballast mass, by subtracting the mass of the test driver and test equipment from the required 200 kg interior load.

#### 3.11.5.4.6 Vehicle Preparation

3.11.5.4.6.1 Fit the on-board test equipment and instrumentation in the vehicle. Also, fit any associated cables, cabling boxes and power sources.

3.11.5.4.6.2 Place weights with a mass of the ballast mass. Any items added shall be securely attached to the car.

3.11.5.4.6.3 With the driver in the vehicle, weigh the front and rear axle loads of the vehicle.

3.11.5.4.6.4 Compare these loads with the "unladen kerb mass".

3.11.5.4.6.5 The total vehicle mass shall be within  $\pm 1\%$  of the sum of the unladen kerb mass, plus 200kg. The front/rear axle load distribution needs to be within 5% of the front/rear axle load distribution of the original unladen kerb mass plus full fuel load. If the vehicle differs from the requirements given in this paragraph, items may be removed or added to the vehicle which has no influence on its performance. Any items added to increase the vehicle mass shall be securely attached to the car.

3.11.5.4.6.6 Repeat paragraphs 3.11.5.4.6.3 and 3.11.5.4.6.4 until the front and rear axle loads and the total vehicle mass are within the limits set in paragraph 3.11.5.4.6.5. Care needs to be taken when adding or removing weight in order to approximate the original vehicle inertial properties as close as possible. Record the final axle loads in the test details. Record the axle weights of the VUT in the 'as tested' condition.

3.11.5.4.6.7 Verify the x-y coordinates for the virtual front end vehicle contour given by the manufacturer. When the coordinates given are within 10mm of those measured by the technical service, the coordinates as provided by the manufacturer will be used. When the coordinates are not within 10mm, the coordinates as measured by the laboratory will be used.

### 3.11.6 Test Procedure

#### 3.11.6.1 VUT Pre-test Conditioning

##### 3.11.6.1.1 General

3.11.6.1.1.1 A new car is used as delivered to the technical service.

3.11.6.1.1.2 If requested by the vehicle manufacturer, drive a maximum of 100km on a mixture of urban, rural roads or proving ground with other traffic and roadside furniture to ‘calibrate’ the sensor system. Avoid harsh acceleration and braking.

##### 3.11.6.1.2 Brakes

3.11.6.1.2.1 Condition the vehicle’s brakes in the following manner, if it has not been done before or in case the lab has not performed a 100km of driving:

- (1) Perform twenty stops from a speed of 56km/h with an average deceleration of approximately 0.5 to 0.6g.
- (2) Immediately following the series of 56km/h stops, perform three additional stops from a speed of 72km/h, each time applying sufficient force to the pedal to operate the vehicle’s antilock braking system (ABS) for the majority of each stop.
- (3) Immediately following the series of 72km/h stops, drive the vehicle at a speed of approximately 72km/h for five minutes to cool the brakes.

##### 3.11.6.1.3 Tires

3.11.6.1.3.1 Condition the vehicle’s tires in the following manner to remove the mould sheen, if this has not been done before for another test or in case the lab has not performed a 100km of driving:

- (1) Drive around a circle of 30m in diameter at a speed sufficient to generate a lateral acceleration of approximately 0.5 to 0.6g for three clockwise laps followed by three anticlockwise laps.
- (2) Immediately following the circular driving, drive four passes at 56km/h, performing ten cycles of a sinusoidal steering input in each pass at a frequency of 1Hz and amplitude sufficient to generate a peak lateral acceleration of approximately 0.5 to 0.6g.
- (3) Make the steering wheel amplitude of the final cycle of the final pass double that of the previous inputs.

3.11.6.1.3.2 In case of instability in the sinusoidal driving, reduce the amplitude of the steering input to an appropriately safe level and continue the four passes.

#### 3.11.6.1.4 AEB/FCW System Check

3.11.6.1.4.1 Before any testing begins, perform a maximum of ten runs at the lowest test speed the system is supposed to work, to ensure proper functioning of the system.

#### 3.11.6.2 Test Scenarios

3.11.6.2.1 The performance of the system is assessed in different scenarios. For AEB Pedestrian the scenarios CPFA-50, CPNA-25, CPNA-75, CPNC-50 and CPLA are considered as shown in Figures 9a, 9b, 9c and 9d respectively.

3.11.6.2.2 For AEB Bicyclist the CBNA and CBLA scenarios are considered as shown in Figures 10a and 10b.

3.11.6.2.3 For testing purposes, assume a straight line path equivalent to the centreline of the lane in which the collision occurred, hereby known as the test path. Control the VUT with driver inputs or using alternative control systems that can modulate the vehicle controls as necessary to perform the tests.

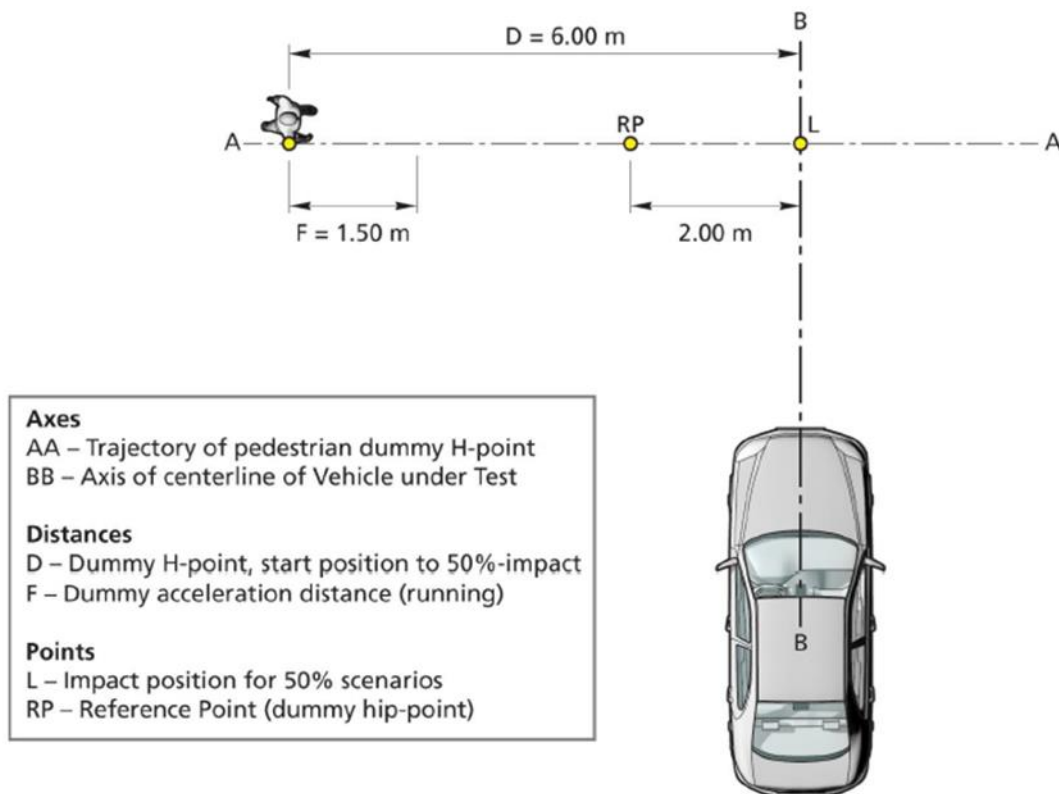

Figure 9a: CPFA-50 scenario, Adult running from Farside

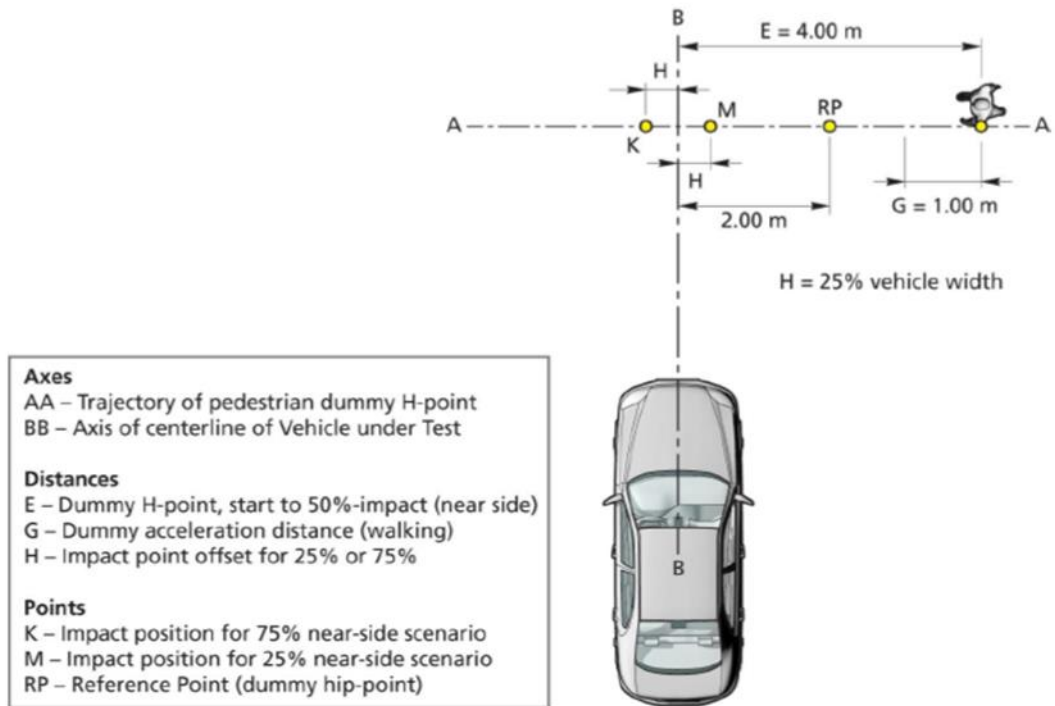

Figure 9b: CPNA-25 & CPNA-75 scenarios, Walking Adult from Nearside

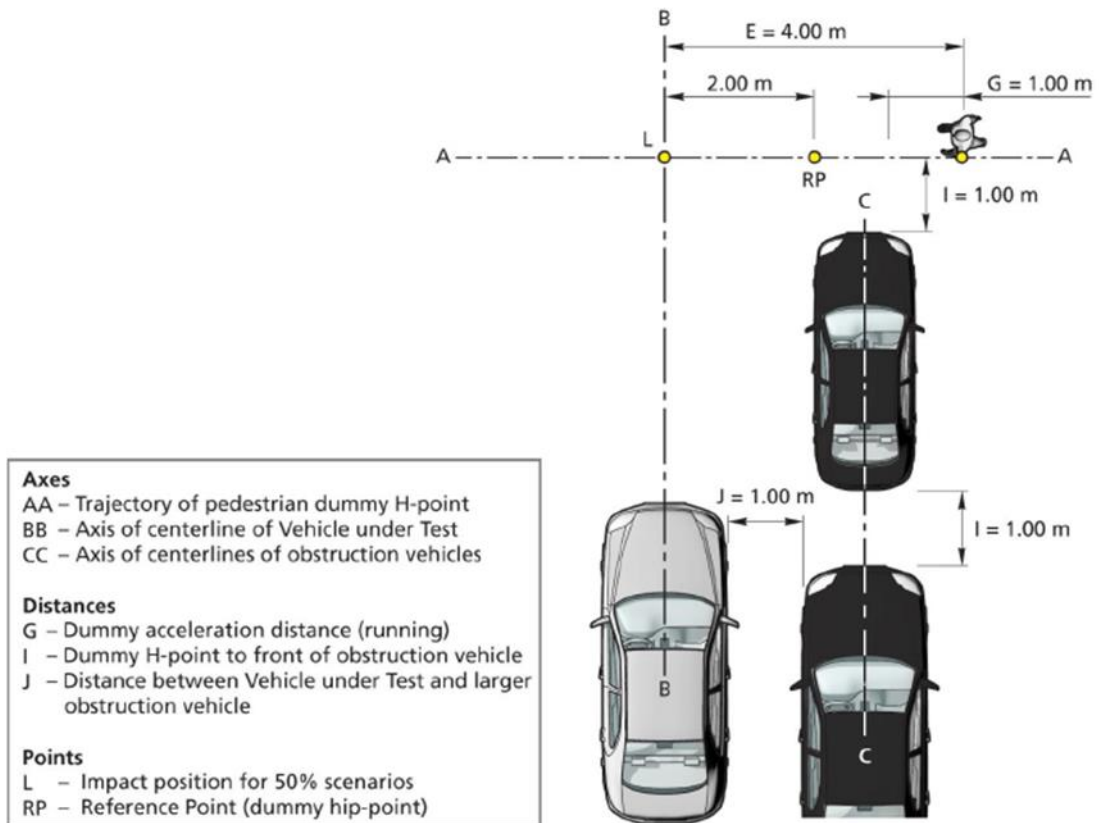

Figure 9c: CPNC-50 scenario, Running Child from Nearside from Obstruction vehicles (see 3.11.7)

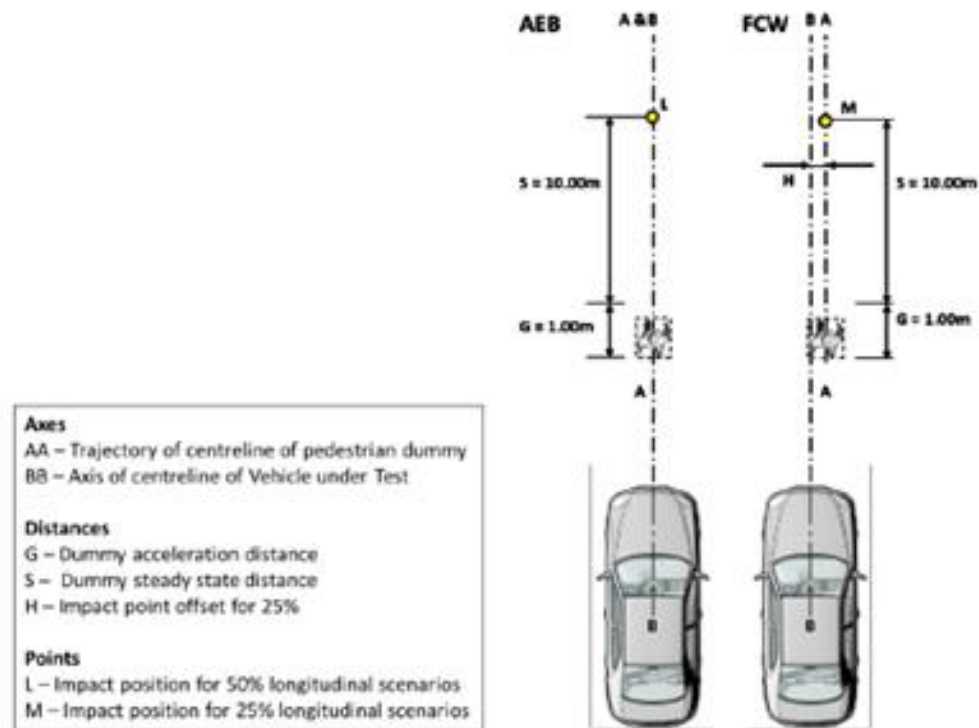

Figure 9d: CPLA scenario, Longitudinal walking Adult

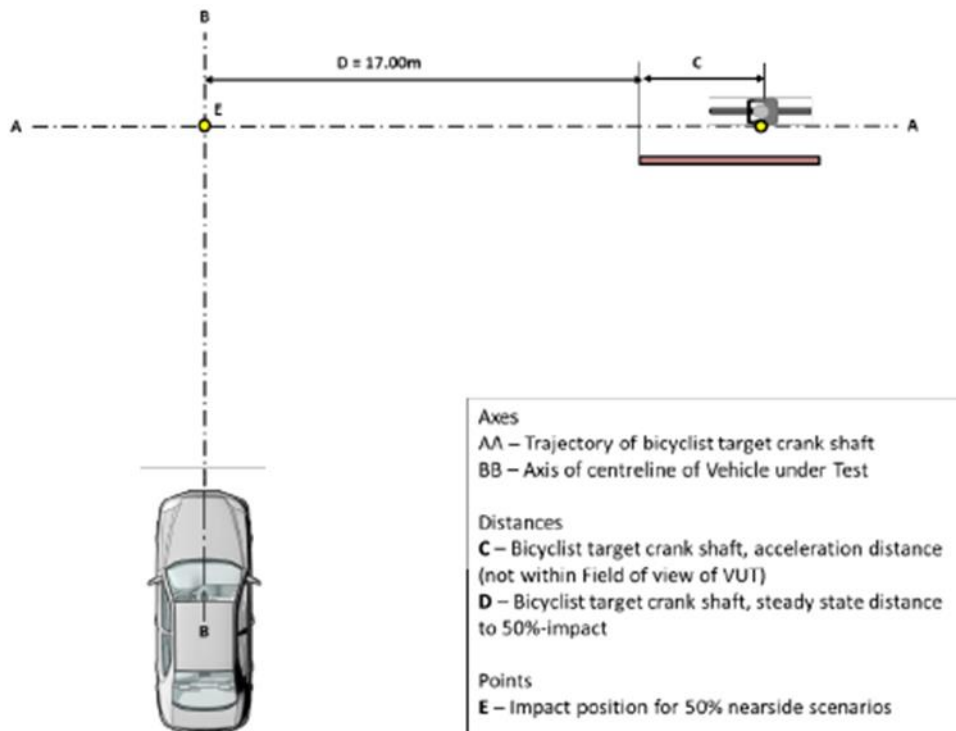

Figure 10a: CBNA scenario, Bicyclist from Nearside

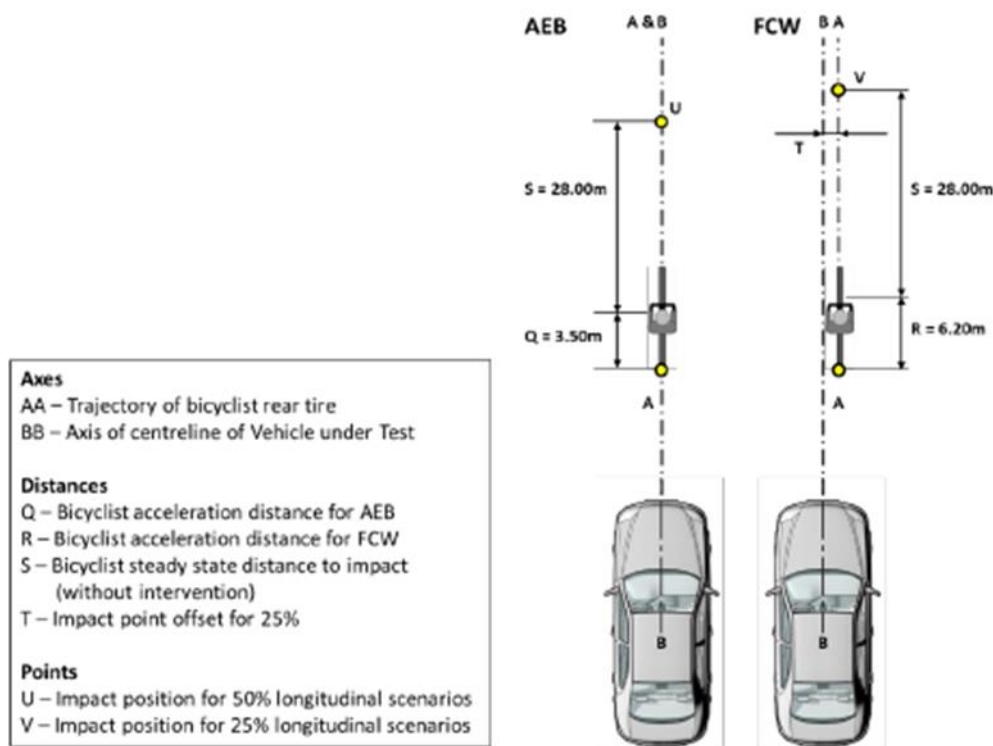

Figure 10b: CBLA scenarios, Longitudinal Bicyclist (AEB left & FCW right)

3.11.6.2.4 All tests will be performed with 5 km/h incremental steps within the speed ranges as summarized in the tables below:

AEB Pedestrian						
	CPFA-50	CPNA-25	CPNA-75	CPNC-50	CPLA-50	CPLA-25
Type of test	AEB					FCW
VUT speed	20-60 km/h					50-80 km/h
Target speed	8 km/h				5 km/h	
Impact location	50%	25%	75%	50%	50%	25%
Lighting condition	Day	Day & Night		Day	Day & Night	
Vehicle lights (night)	Low beam			High beam		
Streetlights (night)	Streetlights as per Annex B			No streetlights		

AEB Bicyclist			
	CBNA-50	CBLA-50	CBLA-25
	AEB		FCW
VUT speed	20-60 km/h	25-60 km/h	50-80 km/h
Target speed	15 km/h		20 km/h
Impact location	50%		25%
Lighting condition	Day		

3.11.6.2.5 For the CPNA-75 scenario the following additional tests are performed as part of the prerequisite verification:

- (1) Test speed of 20km/h with an EPTa speed of 3 km/h
- (2) Test speed of 10km/h (or min. idle speed in 1st gear) with an EPTa speed of 5 km/h

### 3.11.6.3 Test Conduct

3.11.6.3.1 Before every test run, drive the VUT around a circle of maximum

diameter 30m at a speed less than 10km/h for one clockwise lap followed by one anticlockwise lap, and then maneuver the VUT into position on the test path. If requested by the OEM an initialization run may be included before every test run. Bring the VUT to a halt and push the brake pedal through the full extent of travel and release.

3.11.6.3.2 For vehicles with an automatic transmission select D. For vehicles with a manual transmission select the highest gear where the RPM will be at least 1500 at the test speed.

3.11.6.3.3 Perform the first test a minimum of 90s and a maximum of 10 minutes after completing the tire conditioning (if applicable), and subsequent tests after the same time period. If the time between consecutive tests exceeds 10 minutes perform three brake stops from 72 km/h at approximately 0.3g.

Between tests, maneuver the VUT at a maximum speed of 50km/h and avoid riding the brake pedal and harsh acceleration, braking or turning unless strictly necessary to maintain a safe testing environment.

#### 3.11.6.4 Test Execution

3.11.6.4.1 Accelerate the VUT and EPT or EBT to the respective test speeds.

3.11.6.4.2 The test shall start at  $T_0$  (4s TTC) and is valid when all boundary conditions are met between  $T_0$  (for CPLA & CBLA-AEB  $T_0-1s$ ) and  $T_{AEB}$  and/or  $T_{FCW}$ :

(1) Speed of VUT (GPS-speed) Test speed  $\pm 0.5$  km/h

(2) Lateral deviation from VUT test path  $0 \pm 0.05$  m

(3) Lateral deviation from EPT and EBT test path

(A) crossing scenarios  $0 \pm 0.05$  m

(B) longitudinal scenarios  $0 \pm 0.15$  m

(C) lateral velocity  $0 \pm 0.15$  m/s

(4) Yaw velocity  $0 \pm 1.0$  °/s

(5) Steering wheel velocity  $0 \pm 15.0$  °/s

(6) Speed of EPT or EBT during steady state  $\pm 0.2$  km/h

(7) Start of steady state

(A) EPT Nearside 3.0 m from vehicle centreline

(B) EPT Farside 4.5 m from vehicle centreline

(C) EBT Nearside 17m from vehicle centreline

(D) EPT and EBT Longitudinal 10 and 28m from vehicle impact point

3.11.6.4.3 The end of a test, where the AEB function is assessed, is considered when one of the following occurs:

- (1)  $V_{VUT} = 0\text{km/h}$  (crossing) or  $V_{VUT} = V_{EPT/EBT}$  (longitudinal)
- (2) Contact between VUT and EPT or EBT
- (3) EPT or EBT has left the VUT path or VUT has left the EPT or EBT path

3.11.6.4.4 For manual or automatic accelerator control, it needs to be assured that during automatic brake the accelerator pedal does not result in an override of the system. The accelerator pedal needs to be released when the initial test speed is reduced by 5 km/h. There shall be no operation of other driving controls during the test, e.g. clutch or brake pedal. This does not apply for the CPRA tests.

3.11.6.4.5 For AEB systems tests, when there is complete avoidance (if applicable, test results below 20km/h may be ignored), the subsequent test speed for the next test is incremented with 10km/h. When there is contact, first perform a test at a test speed 5km/h less than the test speed where contact occurred. After this test continue to perform the remainder of the tests with speed increments of 5km/h.

For tests above 20km/h, stop testing when the manufacturer predicts no performance. In the tests above 40km/h, stop testing when the actual speed reduction measured is less than 15km/h.

For FCW systems tests, when the FCW is issued before 1.7s TTC, the subsequent test speed for the next test is incremented with 10km/h. When the FCW is issued after 1.7s TTC, first perform a test at a test speed 5km/h less than the test speed where this occurred. After this test continue to perform the remainder of the tests with speed increments of 5km/h.

Stop testing when the manufacturer predicts that the FCW is not issued before 1.5s TTC.

3.11.6.4.6 Where the predicted speed reduction in the tests above 40 km/h is at least 20km/h (sufficient to score points), but the actual speed reduction measured in the test is between 15 and 20km/h, the test shall be repeated a further two times and the middle value will be used in the assessment.

In case FCW triggers between 1.5 and 1.7s TTC, the test shall be repeated a further two times and the middle value will be used in the assessment.

### 3.11.7 Obstruction Dimensions

#### 3.11.7.1 Smaller obstruction vehicle

The smaller obstruction vehicle shall be of the category Small Family Car

and is positioned closest to the pedestrian path. The smaller obstruction vehicle shall be within the following geometrical dimensions and needs to be in a dark color.

	<b>Vehicle Length</b>	<b>Vehicle width (without mirrors)</b>	<b>Vehicle Height</b>	<b>Bonnet length (till A pillar)</b>	<b>BLE height</b>
<b>Minimum</b>	4100 mm	1700 mm	1300 mm	1100 mm	650 mm
<b>Maximum</b>	4400 mm	1900 mm	1500 mm	1500 mm	800 mm

#### 3.11.7.2 Larger obstruction vehicle

The larger obstruction vehicle shall be of the category Small Off-road 4x4 and is positioned behind the smaller obstruction vehicle. The larger obstruction vehicle shall be within the following geometrical dimensions and needs to be in a dark color.

	<b>Vehicle Length</b>	<b>Vehicle width (without mirrors)</b>	<b>Vehicle Height</b>
<b>Minimum</b>	4300 mm	1750 mm	1500 mm
<b>Maximum</b>	4700 mm	1900 mm	1800 mm

### 3.11.8 Testing at Low Ambient Lighting Conditions

#### 3.11.8.1 Illumination Situation

Based on a GIDAS hotspot analysis, this protocol will describe a test condition for a night test scenario in urban situations.

#### 3.11.8.2 Reference EN 13201

This European Standard defines performance requirements, which are specified as lighting classes for road lighting aiming at the visual needs of road users, and it considers environmental aspects of road lighting.

EN 13201, Road lighting is a series of documents that consists of the following parts:

- (1) Part 1: Guidelines on selection of lighting classes [Technical Report]
- (2) Part 2: Performance requirements [present document]
- (3) Part 3: Calculation of performance
- (4) Part 4: Methods of measuring lighting performance
- (5) Part 5: Energy performance indicators

#### 3.11.8.3 Terms and definitions

$E$  - horizontal illuminance over a road area measured in lux (lx)

$\overline{E_{min}}$  - horizontal illuminance averaged over a road area measured in lux (lx)

$E_{min}$  - lowest illuminance on a road area measured in lux (lx)

$\overline{E_{max}}$  - horizontal illuminance averaged over a road area measured in lux (lx)

Reference point R - The reference point of the lamp shall be the geometric centre of the light field

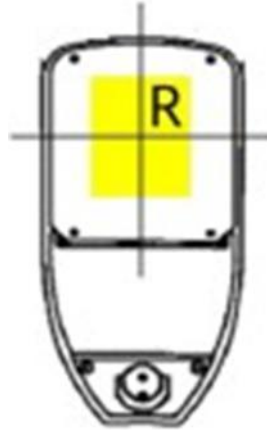

#### 3.11.8.3.1 Derivation of parameter

The test condition in this protocol is based on accident analysis. The illumination values refer to DIN EN 13201.

The main illumination situations are main roads in urban situations with velocity 30...60 km/h, where main users are motorized vehicles and where bicycles and pedestrians are permitted.

The illuminance is based on class ME3. For ME3 comparative classes are available: C3 und S1. For Illuminance class S1 following values are defined in EN 13201:

Values for Class S1:

$$\overline{E_{min}} > 15lx \text{ AND } E_{min} > 5lx$$

$$\overline{E_{max}} < 1,5 * \overline{E_{min}} \text{ AND } \overline{E_{max}} < 22,5lx$$

$\overline{E_{ref}}$  - In order to reach a stable measurement setup, a reference value is defined as:

$$\overline{E_{ref}} = \frac{\overline{E_{min}} + \overline{E_{max}}}{2} = \frac{15lx + 22,5lx}{2} = 18,75lx$$

#### 3.11.8.4 Light Condition

There is a wide range of illuminance values in different situations. (see figure below).

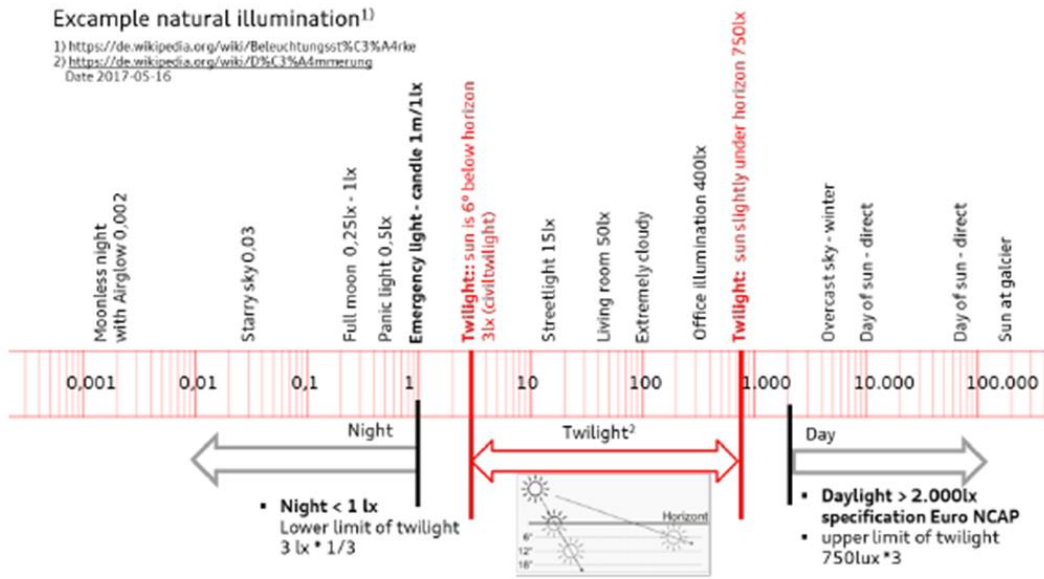

### 3.11.8.4.1 Background Illuminance

The background illumination is an additive value to the streetlight illumination.

The position of the measurement of the background illumination shall be measured at the collision point. During measurement of background illumination all lamps and vehicle light shall be switched off.

Maximum of the background illumination on a test area during night shall be less than:

$$I_{EB} < 1 \text{ lx}$$

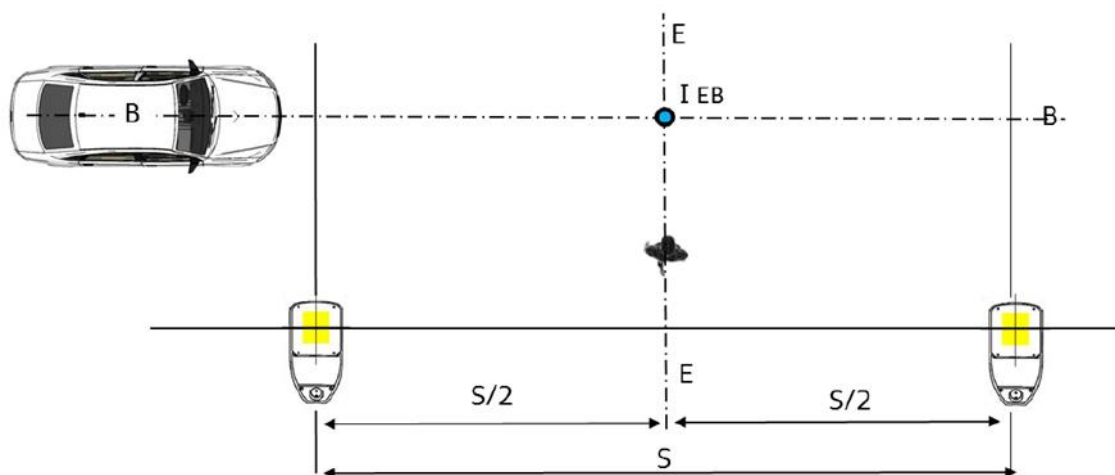

$EE$ : Axis of centerline of pedestrian dummy

$BB$ : Axis of centerline of Vehicle under Test

$S$ : Distance between street lamps

• : Measurement point

### 3.11.8.4.2 Illuminance at VUT Path

The illuminance of VUT path ( $\overline{IVUT}$ ) is defined as an average of illuminance measurement points along the VUT path, trajectory BB. The average illuminance shall be in a range of:

$$\overline{IVUT} = \overline{Eref} \pm Tolerance = 19lx \pm 3lx$$

$$\overline{IVUT} = \frac{1}{11} \sum_{i=1}^{11} IVUT_i; \quad 16lx < \overline{IVUT} < 22lx$$

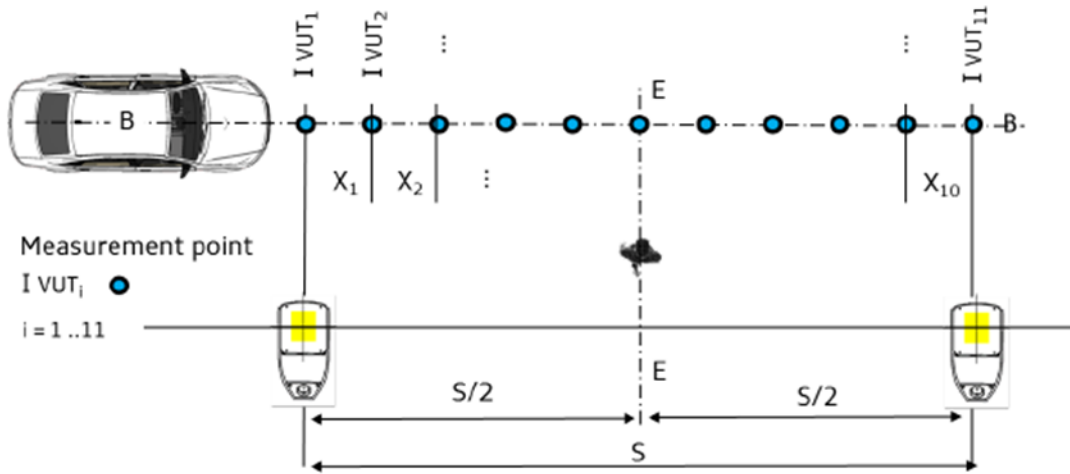

EE: Axis of centreline of pedestrian dummy

BB: Axis of centreline of Vehicle under Test

S: Distance between street lamps

$X_i$ : Distance between measurement points  $X_1, X_2, \dots, X_{10} = S/10$

#### 3.11.8.4.3 Illuminance at EPT Path

The illuminance along the EPT path, trajectory EE shall be at least I

$EPT_i > E_{min}$

$I_{EPT_i} > 5 \text{ lx}$

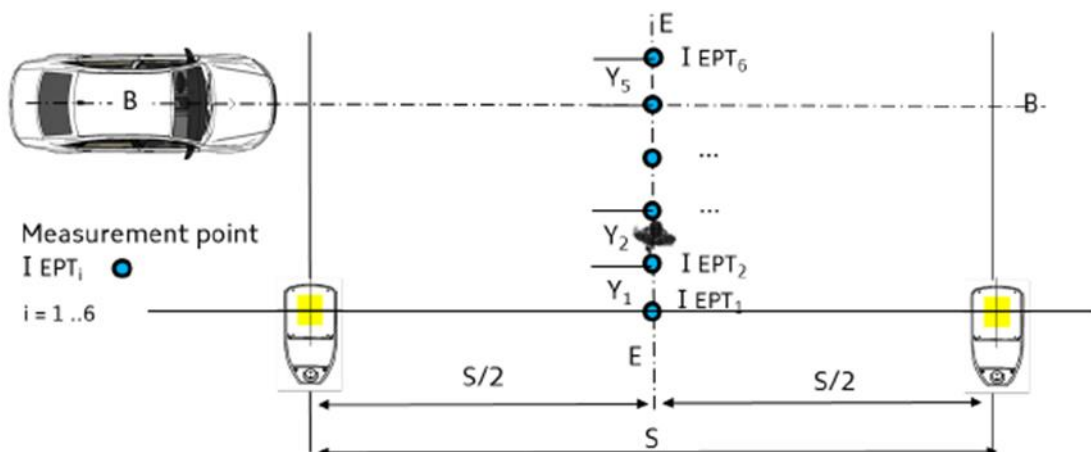

EE: Axis of centreline of pedestrian dummy

BB: Axis of centreline of Vehicle under Test

S: Distance between streetlight

Y<sub>i</sub>: Distance between measurement points Y<sub>1</sub>, Y<sub>2</sub>, .. Y<sub>5</sub> = 1m

3.11.8.4.4 Measurement Tolerances All measurement tolerances shall be EE: ±1lx

### 3.11.8.5 Test Equipment

#### 3.11.8.5.1 General Requirement

The chosen lamp setup must reflect real world conditions. It is not allowed to install separate lamps to reach the required conditions. For the night test, a LED lamp shall be used due to its overall advantages like homogeneous illumination, long-term stability, power consumption etc.

#### 3.11.8.5.2 Glaring

The lamps shall not be tilted towards the SV path to avoid any glaring which could affect the sensor performance. Glaring of the sensor system shall not occur everywhere on the test area and especially not along the section of the vehicle path.

#### 3.11.8.5.3 Constant Illumination Function

To reach constant test conditions during test and lifetime, the lamp shall have a constant illumination function.

#### 3.11.8.5.4 Color Temperature

The color temperature of the lamps shall be between 4500±1000K.

#### 3.11.8.5.5 Mounting Device

The lamps can be either installed stationary on a fixed pole, or on a mobile tripod. The mounting device must be designed to withstand wind speeds up to 20m/s.

#### 3.11.8.5.6 Free Space (F)

In the passenger side of the VUT test path it is not allowed to install any mounting device from the lamp.

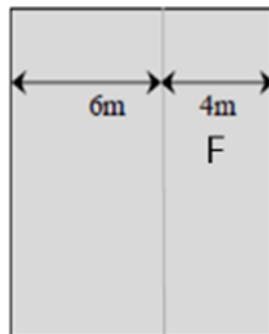

The free space F between the VUT path and the mounting facility shall be  $F \geq 4m$ .

#### 3.11.8.5.7 Test Setup

Three lamps in front of the pedestrian path and two lamps behind the pedestrian path are recommended (see figure below). That lamp

configuration provides a homogeneous illumination of the test scenario according to real world situations.

The position of the EPT is between lamp 3 and 4.

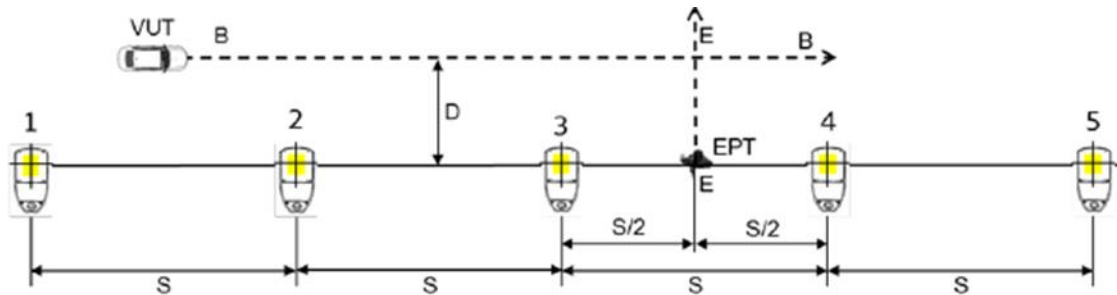

D: Lateral distance between the centre of the light field and the VUT path

EE: Axis of centreline of pedestrian dummy

BB: Axis of centreline of Vehicle under Test

VUT: Vehicle under Test

EPT: Euro NCAP Pedestrian Target

S: Distance between streetlight

#### 3.11.8.5.8 EPT Position

The EPT track EE shall be positioned between the street lamp 3 and 4 and passes the centreline of the EPT. Reference point for test setup is trajectory AA, which passes the pedestrian dummy H-point.

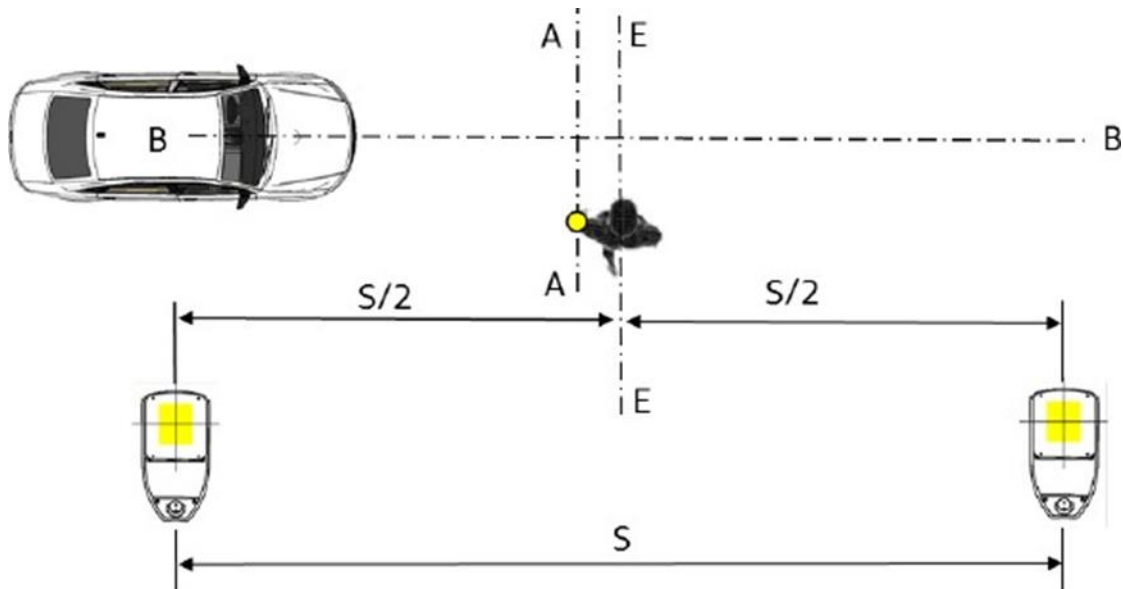

AA: Trajectory of pedestrian dummy H-point

BB: Axis of centerline of Vehicle under Test (VUT) EE: Axis of centerline of pedestrian dummy

S: Distance between street lamps

### 3.11.8.6 Example Test Equipment

As a reference and to demonstrate feasibility, the following sections provides example test equipment, test set-up and reference measurements that can be taken to ensure that the set-up will meet the requirements of this protocol.

#### 3.11.8.6.1 Lamp Type

Schuch, 48\_LED (48 2403 ABX CL)



#### 3.11.8.6.2 Requirement test setup adjustment

To be sure to reach requirement 3.11.8.4.2 and 3.11.8.4.3 the following parameters are allowed to be adjusted.

The distance of the lamp shall be adjustable in order to reach the requested illumination values. S:  $25\text{m} \pm 0.5\text{m}$

The lateral distance between the centre of the LED-area and the vehicle path is adjustable in a range of

D:  $4.0\text{m} \pm 0.1\text{m}$

The height of the lamp shall be adjustable in order to reach the requested illumination values. H:  $5\text{m} \pm 0.1\text{m}$

Angle against ground and pole.

a:  $90^\circ \pm 0.5^\circ$

The tilt of the lamp is adjustable in three different positions. ( $0^\circ$  standard,  $5^\circ$ ,  $10^\circ$ )

T:  $0^\circ$  standard position

The inclination of road and test site surfaces is typically  $\sim 2.5\%$

c:  $< 1.5^\circ$

To ensure that the centre lines L of the lamps are oriented at right angles to the street even under the above conditions the length of the control line C shall be verified. Approval for the two lamps adjacent to the pedestrian path is sufficient.

$$c = \sqrt{D^2 + H^2} = \sqrt{4\text{m}^2 + 5\text{m}^2}$$

C:  $6.4\text{m} \pm 0.1\text{m}$

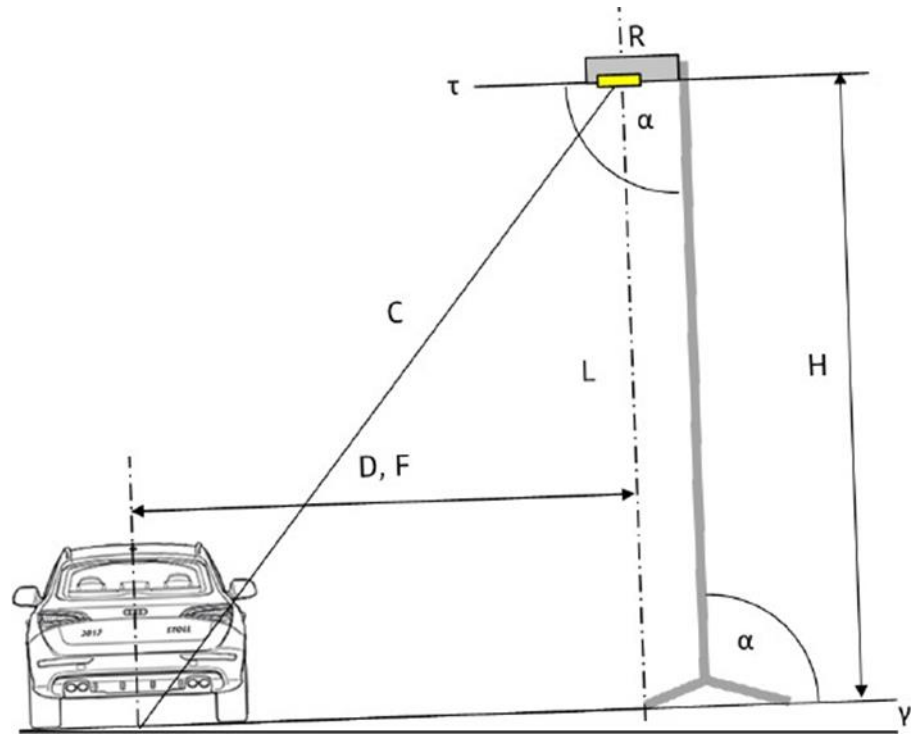

R: Reference point geometric centre of the light field

L: Centre line of the lamp (parallel to the pole)

D: Lateral distance between the centre of the light field and the VUT

path F: Free space between driving path of VUT and equipment

H: Height of lamp C: Control line

$\tau$ : Tilt of lamp

$\alpha$ : Angle against ground and pole

$\gamma$ : Cross slope

### 3.11.8.6.3 Longitudinal inclination of lamp

In order to get well balanced light distribution, it is necessary that the inclination of the lamp is in a range of:

$$\beta_{1,2}: 90^\circ \pm 0.5^\circ$$

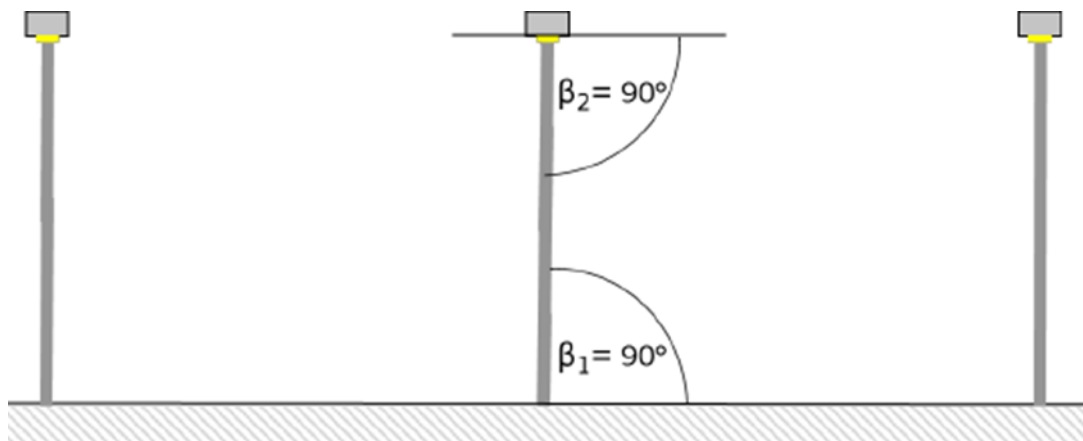

$\beta_1$ : inclination of lamp to ground

$\beta_2$ : inclination of lamp to pole

#### 3.11.8.6.4 Orientation of lamp

In order to get well balanced light distribution, it is necessary that the rotation of the lamp in a range of:

P:  $90^\circ \pm 0.1^\circ$

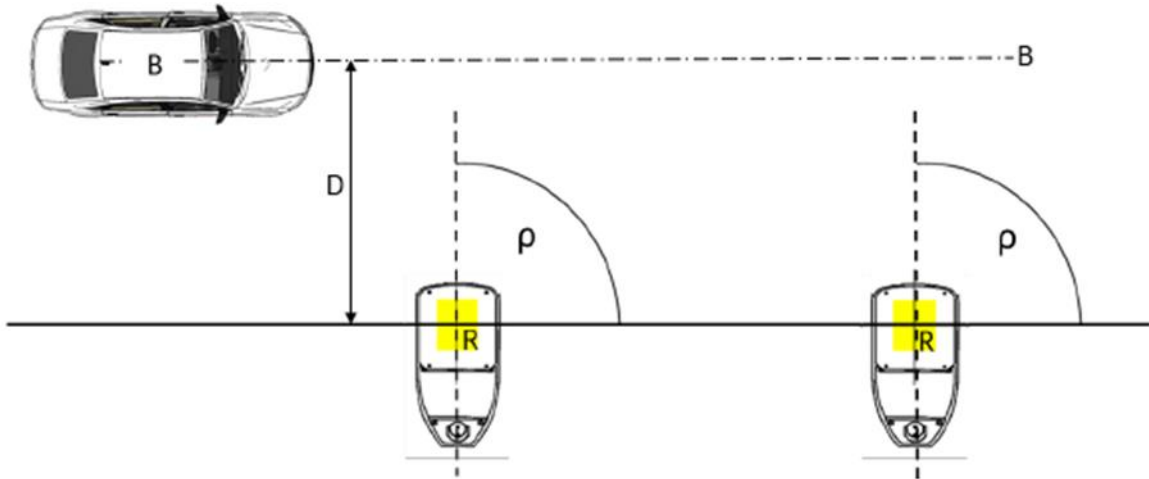

BB: Axis of centerline of Vehicle under Test

F: Free space between driving path of VUT and equipment

D: Lateral distance between the center of the light field and the VUT path

R: Reference point geometric center of the light field

$\rho$ : Rotation of lamp

#### 3.11.8.6.5 Example solutions

It is not allowed to install any mounting device within the free space. Different solutions are possible to reach the requirement as defined in 3.11.8.5.6.

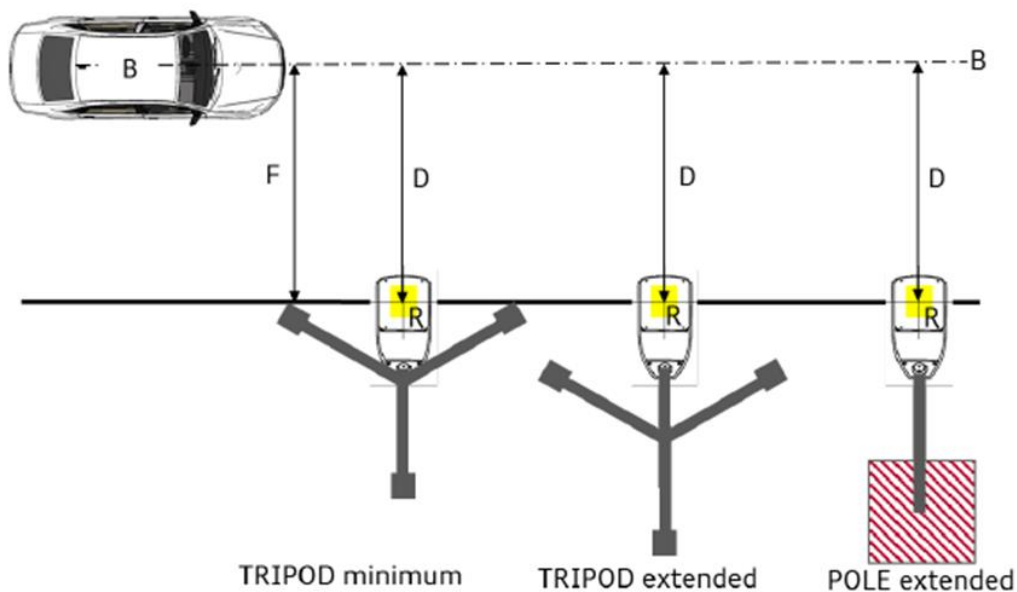

BB: Axis of centreline of Vehicle under Test

F: Free space between driving path of VUT and equipment

D: Lateral distance between the center of the light field and the VUT path

R: Reference point geometric center of the light field

#### 3.11.8.6.6 Example mounting devices

It is not allowed to install any mounting device within the free space. Different solutions are possible to reach the requirement as defined in 3.11.8.5.6.

Towerlight TF5.5

<http://www.towerlight.de/produkt/tf-5-5-7m/> (Date 2017-05-15)



*configuration tripod*



*configuration cement pole*

#### 3.11.8.7 Measurement

To ensure, that the parameter defined in 3.11.8.4.1, 3.11.8.4.2 and 3.11.8.4.3 are in line with test setup, the parameter must be verified and documented.

##### 3.11.8.7.1 Measurement setting

To measure the illumination, a calibrated luxmeter must be set on ground in a right angle to the street.  $P: < 0.2\text{m}$

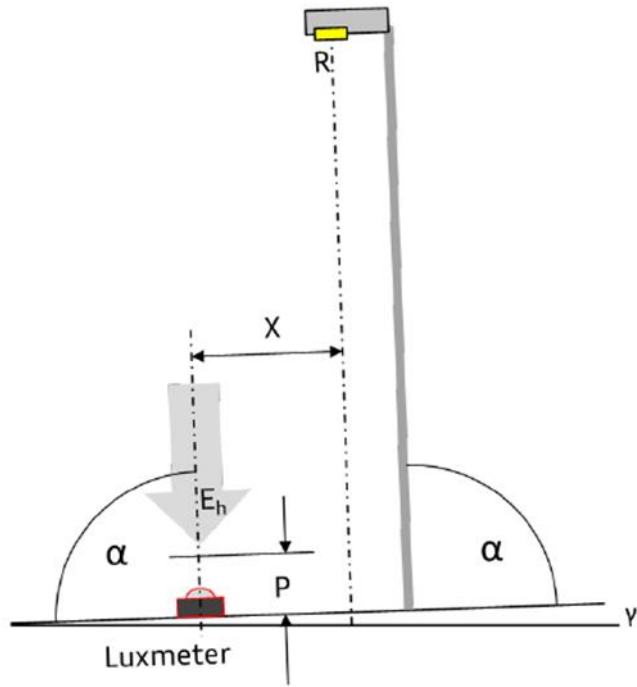

$E_h$ : horizontal illumination

R: Reference point geometric center of the light field

P: maximal height over ground

X: Position X

$\alpha$ : Angle against ground

### 3.11.8.7.2 Example measurement grid

To ensure, that the parameter defined in 3.11.8.4.1, 3.11.8.4.2 and 3.11.8.4.3 are in line with test setup, the parameter must be verified and documented.

For IEPT5, IVUT6, IEB the position for measurement is:

X=12,5m, Y=4,0m.

The other values see figure below.

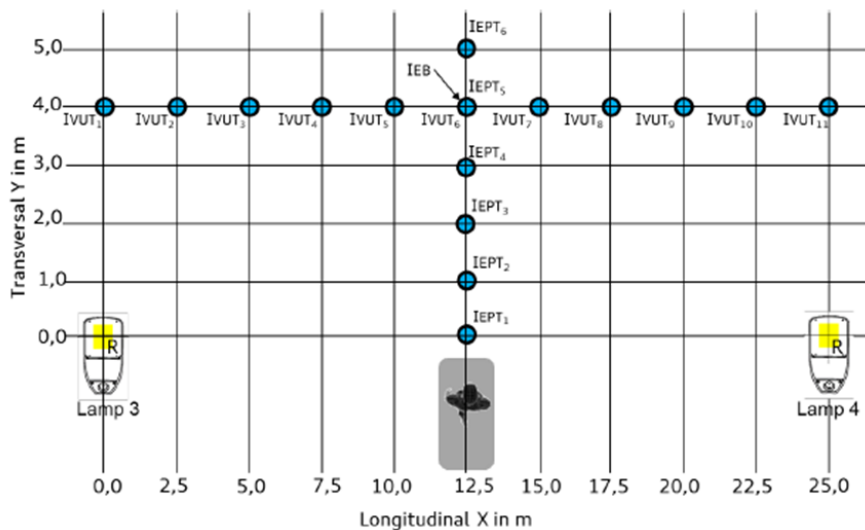

R: Reference point geometric centre of the light field

• : Measurement point

### 3.11.8.7.3 Example measurement tools

To measure the illuminance values, a calibrated luxmeter shall be used.

The tolerance shall be:

Maximal error tolerance < 5%.

Luxmeter LMT B 360

<http://www.lmt-berlin.de/de/b360.html> (Date 2017-05-15)



*Luxmeter LMT B 360*

Luxmeter Konika T-10A

<https://www.konicaminolta.eu/de/messgeraete/produkte/licht-messtechnik/luxmeter/t-10a/einfuehrung.html> (Date 2017-05-15)



*figure: Luxmeter Konika T-10A*

### 3.11.8.7.4 Measurement documentation

The following values shall be measured and documented before and after a complete test series.

(1) Background illuminance  $I_{EB}$  (3.11.8.4.1)

With all lamps and vehicle lights switched OFF, measure and record  $I_{EB}$  before and after a full test series.

(2) Illuminance at VUT, EPT path (3.11.8.4.2 and 3.11.8.4.3)

With all lamps ON and vehicle lights OFF, measure and record the illuminance at VUT and EPT path.