

**Ministry of Transportation and
Communications**

**Taiwan New Car Assessment Program
(TNCAP)**

Second Version

**3.15 Electric Vehicle Post-Collision Electric
Shock Protection Testing Protocol**

V2.1
Nov 2025

TABLE OF CONTENTS

3.15.1 Introduction.....	3
3.15.2 Definition of Terms.....	3
3.15.3 Test Preparation.....	5
3.15.4 Test Conditions	6
3.15.5 Recording, Measurement Items, and Measurement Range	8
3.15.6 Treatment of Measured Values.....	9
3.15.7 Evaluation of Electrical Shock Protection Performance during Collision Test for Electric Vehicles.....	9
3.15.8 Protection from Direct Contact with Live Parts of Power System	10
3.15.9 Measurement of Isolation Resistance	13
3.15.10 Measurement of Residual Voltage	16
3.15.11 Measuring Residual Energy	17

3.15.1 Introduction

This test procedure and assessment apply to Performance Tests for Protection from Electrical Shock after a Collision of the tests conducted by TNCAP which are applicable to M1 category electric vehicles (excluding motor vehicles of which the electric motor operates at a working voltage of less than AC 30 V or DC 60 V).

The test shall be conducted as prescribed herein and according to the provisions of the Offset Frontal Impact Testing Protocol, Full Width Frontal Impact Testing Protocol, Side Impact Testing Protocol, and Pole Side Impact Testing Protocol.

3.15.2 Definition of Terms

3.15.2.1 "Power system": Electric circuits including those described in Section 3.15.2.1.1 to 3.15.2.1.6:

3.15.2.1.1 Traction motor, its accessory wire harness, connectors, etc.

3.15.2.1.2 Rechargeable energy storage system (REESS)

3.15.2.1.3 Electrical energy conversion system

3.15.2.1.4 Electronic converter (meaning devices capable of controlling or converting electric power, such as electronic control of the traction motor and DC/DC converters)

3.15.2.1.5 Auxiliaries related to running (heaters, defrosters, power steering systems, etc.)

3.15.2.1.6 Coupling system for the charging system

3.15.2.2 "High Voltage": The classification of an electric component or circuit, if its working voltage is direct current (DC) of $> 60 \text{ V}$ and $\leq 1,500 \text{ V}$ or alternating current (AC) of 30 V and $\leq 1,000 \text{ V}$ root mean square (rms).

3.15.2.3 "Working Voltage": The highest value of the voltage root mean square (rms) of an electric circuit, specified by the manufacturer, which may occur between any conductive parts in open circuit conditions or under normal operating conditions. If the electric circuit is divided by galvanic isolation, the working voltage is defined for each divided circuit, respectively.

3.15.2.4 "Rechargeable Energy Storage System (REESS)": The rechargeable energy storage system which provides electrical energy to the electric motor for propulsion.

3.15.2.5 "Coupling System for the Charging System": The electric circuit mainly used for charging the rechargeable energy storage system (REESS) from an external electrical power supply and is divided from the power system by galvanic isolation except when connected with an external power supply with a contactor or isolation transformer that opens or closes the electric circuit that includes the items indicated in Section 3.15.2.5.1 to 3.15.2.5.3 below:

- 3.15.2.5.1 Vehicle inlet (meaning part of the vehicle connected to the external power supply)
- 3.15.2.5.2 Wire harness, connectors, etc. between the vehicle inlet and the power system
- 3.15.2.5.3 Electric circuits galvanically connected to the electric circuits prescribed in Section 3.15.2.5.1 and 3.15.2.5.2.
- 3.15.2.6 "External Power Supply": Alternating or direct current electric power supply outside the vehicle.
- 3.15.2.7 "Cabin": The space for occupant accommodation, bounded by the roof, floor, side walls, doors, outside glazing, front bulkhead, and rear bulkhead, or rear gate as well as the electrical protection barriers and enclosures provided for protecting the occupants from direct contact with the live parts of the power system.
- 3.15.2.8 "Direct Contact": The contact of persons with the live parts of the power system.
- 3.15.2.9 "Live Parts": Conductive part(s) intended to be electrically energized in normal use.
- 3.15.2.10 "Indirect Contact": The contact of persons with exposed conductive parts.
- 3.15.2.11 "Protection Degree IPXXB": What is defined in Section 3.15.8, "Protection from Direct Contact with Live Parts of Power System."
- 3.15.2.12 "Exposed Conductive Part": Among the conductive parts which normally are not electrically energized but may become so under isolation failure conditions ("potential conductive parts"), those which can be easily touched without using tools. In such a case, whether the part can be easily touched or not is judged based on whether the part has a structure of protection degree IPXXB.
- 3.15.2.13 "Isolation Resistance": Isolation between the live parts of the power system and exposed conductive parts that can be touched and isolation between the live parts of the power system and electrical chassis.
- 3.15.2.14 "Residual Voltage": The voltage between (Vb) the positive side (V2) and the negative side (V1) of a high-voltage bus prescribed in Section 3.15.10 (on a vehicle with an automatic disconnect, the electric circuit on the side of the traction motor) and the electrical chassis; and the voltage between the positive side (V2) and the negative side (V1) of a high-voltage bus (on a vehicle with an automatic disconnect, the electric circuit on the side of the traction motor), measured between 5 and 60 seconds after a collision.
- 3.15.2.15 "Residual Energy": The energy present in the high-voltage parts of the power system measured between 5 and 60 seconds after a collision.

- 3.15.2.16 "Electrical Circuit": An assembly of connected live parts of the power system which is designed to be electrically energized in normal operation.
- 3.15.2.17 "High-Voltage Bus": The electric circuit, including the coupling system for charging the REESS that operates on a high voltage.
- 3.15.2.18 "Electrical Circuit on the REESS Side": The part of the power system electric circuits, disconnected by the automatic disconnect, which includes the coupling system for charging the REESS.
- 3.15.2.19 "Electrical Circuit on the side of the Traction Motor": The part of the power system electric circuits disconnected by the automatic disconnect which includes the traction motor.
- 3.15.2.20 "Automatic Disconnect": A device that, when sensing an impact from a collision, separates the RESS side circuits from the traction motor side circuits.
- 3.15.2.21 "Electrical Chassis": A set made of conductive parts electrically linked together, whose electrical potential is taken as a reference.
- 3.15.2.22 "Electrical Energy Convergence System": A system (e.g. fuel cell) that generates and provides electrical energy for electrical propulsion.
- 3.15.2.23 "Electrical Protection Barrier": The part providing protection against direct contact, from any direction, with the high-voltage live parts.
- 3.15.2.24 "Enclosure": The part enclosing the internal units and providing protection against contact from any direction.
- 3.15.2.25 "Open Type Traction Battery": A type of battery requiring liquid and generating hydrogen gas released to the atmosphere.

3.15.3 Test Preparation

3.15.3.1 Data Provision from the Manufacturer

Manufacturers shall submit to TNCAP in advance the following data necessary to prepare the test.

- (1) Specifications of the electric vehicle under test.
- (2) Special matters to be confirmed concerning the test preparation and measurement procedure (confirmation relating to the test preparation and measurement method specific to the vehicle type being tested or certain vehicle types including the vehicle type.)

3.15.3.2 Wiring Work for Electric Vehicle

Manufacturers shall assign personnel to perform the wiring work free of charge and coordinate with the technical service. This work shall be completed at the laboratory at least one week before vehicle preparation. If the manufacturer cannot provide assistance with these matters, the rating for this item will not be met, and a score of zero will be given for the frontal offset impact, full-width frontal

impact, side impact, and side pole impact ratings.

3.15.4 Test Conditions

3.15.4.1 Test Vehicle Conditions

3.15.4.1.1 Rechargeable Energy Storage System (REESS): The rechargeable energy storage system (REESS) shall be charged to its normal state of operation prescribed by the manufacturer, etc. Furthermore, if the RESS is an open type traction battery that is open to the atmosphere and needs water refilling, it shall be filled with electrolyte to the prescribed maximum amount.

3.15.4.1.2 Electronic Converter: The vehicle may be subjected to a collision test with the electronic converter turned off, the working principle of the electronic converter having been clearly presented. To do so, other than turning the electronic converter off, necessary modification may be added such as modification of software programs.

3.15.4.1.3 Automatic Disconnect: The automatic disconnect shall operate normally upon collision; provided, however, that, in conducting the test, if TNCAP finds that operating conditions of the automatic disconnect prescribed by the manufacturer are not satisfied, the test may be conducted with the electric circuit on the REESS side disconnected from the electric circuit on the side of the traction motor.

3.15.4.2 Preliminary Preparations

3.15.4.2.1 Indicator Lamp Confirming the Operation of the Automatic Disconnect: A lamp allowing the state of operation of the automatic disconnect to be confirmed from outside the vehicle shall be provided at a conspicuous location on the side rear part of the vehicle to be tested; provided, however, that this shall not apply when the state of operation of the automatic disconnect can be confirmed easily with an operation indicator lamp provided inside the compartment.

3.15.4.2.2 Requirements for Protection from Electric Shock: Before conducting the test, the technical service shall make the preparations prescribed in paragraph 3.15.4.2.2.1; provided, however, that when offered by the manufacturer, the preparations prescribed in Section 3.15.4.2.2.2 to 3.15.4.2.2.4 shall be made.

3.15.4.2.2.1 Preparing for Measuring Indirect Contact

3.15.4.2.2.1.1 Points for measuring the resistance between conductive parts (except for the coupling system for the charging system) and the electrical chassis shall be determined. Necessary modifications may be made as appropriate so that resistance

can be measured easily after the test.

3.15.4.2.2.1.2 The value of resistance shall be measured between the measurement points determined above and recorded in the test result record sheet.

3.15.4.2.2.2 Preparing for Measuring Isolation Resistance

3.15.4.2.2.2.1 The points for measuring the isolation resistance between the live part of the power system (except for the coupling system for the charging system) and exposed conductive parts that might come into contact with the test probe, and between the live part of the power system and the electrical chassis, shall be determined. Modifications may be made as appropriate so that resistance can be measured easily after the test.

3.15.4.2.2.2.2 The value of isolation resistance shall be measured between the measurement points determined above and recorded in the test result record sheet.

3.15.4.2.2.2.3 Stabilizing the Isolation Resistance: When the values measured above are found to be unstable due to the operation of the isolation resistance drop alarm, etc., modifications necessary for measurement may be made as needed by turning off or removing such devices. When removing such a device, it shall be demonstrated with drawings, etc. that such removal does not affect the isolation resistance between the live part of the power system and the electrical chassis.

3.15.4.2.2.3 Measuring Residual Voltage

3.15.4.2.2.3.1 The points for measuring the voltage in the high-voltage bus shall be determined.

3.15.4.2.2.3.2 After consulting the manufacturer and TNCAP, a device shall be installed that allows the voltage in the high-voltage bus to be measured at any time and the results shall be recorded as necessary.

3.15.4.2.2.4 Measuring Residual Energy

3.15.4.2.2.4.1 The points for measuring the residual energy inside the high-voltage parts of the power system in the high-voltage bus shall be determined.

3.15.4.2.2.4.2 After consulting the manufacturer and TNCAP, a device shall be installed that allows the voltage in the high-voltage bus to be measured at any time and the results shall be recorded as necessary.

3.15.4.2.3 Electrical Protection Barriers and Enclosures: An appropriate paint shall be applied to the electrical protection barriers and enclosures to allow checking for the leakage of electrolyte from the rechargeable energy storage system (REESS) after a collision as necessary.

3.15.4.2.4 Electrolyte and Other Aggregates: Aggregates other than electrolyte (substitute liquids for oil, fuel, etc.) shall be colored so that they can be distinguished or separated from electrolyte as necessary.

3.15.5 Recording, Measurement Items, and Measurement Range

3.15.5.1 Activation of Automatic Disconnect: After the collision test, whether the automatic disconnect was activated or not shall be checked and the result shall be recorded.

3.15.5.2 Requirements for Protection from Electric Shock

3.15.5.2.1 Requirements Regarding Direct Contact: After the collision test, it shall be checked whether the test probe came in direct contact with the live parts (except for the coupling system for the charging system) of the power system (except for the coupling system for the charging system) according to Section 3.15.8: Protection from Direct Contact with Live Parts of Power System, and the results shall be recorded; provided, however, that this shall not apply when protection from electric shock is checked as prescribed in Section 3.15.5.2.4 and 3.15.5.2.5.

3.15.5.2.2 Requirements Regarding Indirect Contact: After the collision test, measurements shall be made of resistance between the conductive parts determined before the test and the electrical chassis, except for the coupling system for the charging system, and it shall be checked where the conductive parts are located (whether there are inside or outside the cabin) as well as whether they are exposed conductive parts or not, and the results shall be recorded.

3.15.5.2.3 Requirements Regarding Isolation Resistance: If necessary from Section 3.15.4.2.2, after the collision test, the isolation resistance between the live parts of the power system (except for the coupling system for the charging system) determined before the test and the exposed conductive parts that came into contact with the test probe, and between the live parts of the power system (except for the coupling system for the charging system) and the electrical chassis, except for the coupling system for the charging system, shall be measured according to Section 3.15.9: Measurement of Isolation Resistance, and the results shall be recorded.

3.15.5.2.4 Requirements Regarding Residual Voltage: If necessary from Section

3.15.4.2.2, the maximum voltage shall be measured at a point in time between 5 seconds and 60 seconds after the collision and recorded. However, this excludes cases where protection from electric shock is confirmed as per Section 3.15.5.2.1.

3.15.5.2.5 Requirements Regarding Residual Energy: If necessary from Section 3.15.4.2.2, the maximum energy shall be measured and recorded at a point in time between 5 seconds and 60 seconds after the collision. However, this excludes cases where protection from electric shock is confirmed as per Section 3.15.5.2.1.

3.15.5.3 Requirements Regarding Electrolyte Leakage from the Rechargeable Energy Storage System (REESS): The state of electrolyte leakage from the rechargeable energy storage system (REESS) shall be checked and recorded. Furthermore, if the system is an open type traction battery, this fact shall be recorded.

3.15.5.4 Requirements Regarding Fixation of the Rechargeable Energy Storage System (REESS): The state of fixation of the rechargeable energy storage system (REESS) shall be checked and recorded.

3.15.5.5 Photographed Data: Immediately after the test, characteristic parts of the rechargeable energy storage system (REESS) that are associated with its safety (e.g. fixation of the system) and their state shall be observed and recorded (photographs taken).

3.15.6 Treatment of Measured Values

3.15.6.1 The measured values of exposed amount of electrolyte shall be rounded off to one decimal place in units of L.

3.15.6.2 The resistance between the exposed conductive parts and the electrical chassis shall be rounded off to four decimal places in units of Ω .

3.15.6.3 The working voltage shall be rounded off to one decimal place in units of V.

3.15.6.4 The isolation resistance for 1 V of working voltage shall be rounded off to three significant figures.

3.15.6.5 The residual voltage shall be rounded off to one decimal place in units of V.

3.15.6.6 The residual energy shall be rounded off to two decimal places in module.

3.15.7 Evaluation of Electrical Shock Protection Performance during Collision Test for Electric Vehicles

3.15.7.1 Evaluation Procedure:

(1) Electrical Shock Protection Performance

(A) Direct contact: Protection against live parts of power systems shall meet IP code IPXXB.

(B) Indirect contact: The value of resistance to the electric chassis connected to

exposed conductive parts and the electrical chassis that is accessible shall be less than 0.1 Ω with a current of 0.2 A or higher.

- (C) Insulation resistance: The operating voltage of an AC circuit and a circuit that includes an AC circuit shall be 500 Ω / V or higher. The operating voltage shall be 100 Ω / V or higher when satisfying the requirements of IP code IPXXB and when the voltage of AC parts is 30 V or less. The operating voltage of a DC circuit shall be 100 Ω / V or higher.
- (D) Residual voltage: Residual voltage of high-voltage parts as of 5 to 60 seconds after a collision shall be AC 30 V or less or DC 60 V or less.
- (E) Residual energy: Energy of the high voltage parts of power systems as of 5 to 60 seconds after a collision shall be 2.0J or less.

(2) REESS Electrolyte Leakage Performance

- (A) Electrolyte shall not leak into the passenger compartment.
- (B) When there is electrolyte leakage to the outside of the passenger compartment, the amount of leakage in 30 minutes from the collision shall be 7% or less of the total electrolyte amount. However, for open-type traction batteries, the amount shall be 7% or less of the total electrolyte amount or 5 L or less.

(3) REESS Anchorage Performance

- (A) For the REESS inside the passenger compartment, it shall be anchored in a prescribed position.
- (B) For the REESS outside the passenger compartment, it shall not penetrate into the passenger compartment.

(4) Checking the Operation of Automatic Shutoff Device

- (A) During a collision, the automatic shutoff device shall be activated and the high voltage circuit shut off.

3.15.7.2 Evaluation Results: When the vehicle meets the requirements for electric shock protection performance, REESS electrolyte leakage performance, REESS anchorage performance and operational check of the automatic shutoff device, compliance label (Figure 1) is given.



Figure 1: TNCAP Electric Vehicle Electrical Shock Protection Compliance Label

3.15.8 Protection from Direct Contact with Live Parts of Power System

3.15.8.1 Overview

Protection degree IPXXB regarding direct contact with the live parts of the power

system (excluding the coupling system for the charging system) is as defined in this Attachment. Further, this Attachment applies to power systems of which the working voltage is not more than 1000 V for AC and 1500 V for DC. Furthermore, for the purpose of this Attachment, besides the live parts of the power system prescribed in Section 3.15.8.3.1 of the main text, the parts prescribed in Section 3.15.8.1.1 and 3.15.8.1.2 below are also regarded as live parts of the power system and judged as such.

3.15.8.1.1 The live parts of the power system that are coated with varnish or paint alone; provided, however, that this shall not apply to those which use varnish or paint for isolation.

3.15.8.1.2 The live parts of the power system that are protected by oxidization or similar treatment.

3.15.8.2 Testing Conditions

In principle, the test vehicle shall be in the state it was in immediately after the collision test.

3.15.8.2.1 Test Probe

3.15.8.2.1.1 The test probe to be used to check the protection degree is as prescribed in Table 1.

Table 1: Test Probe

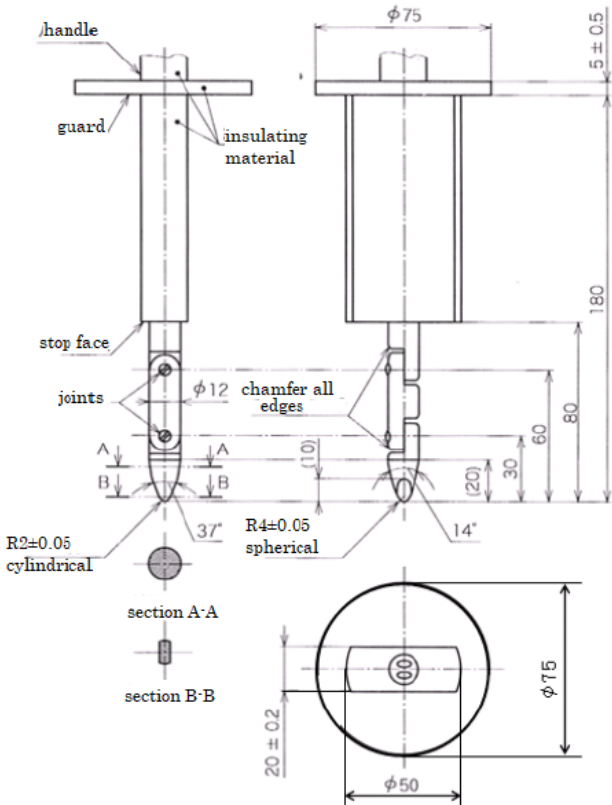
	Test Probe	Test Force
<p>When testing in relation to protection degree IPXXB</p>	 <p>Materials: Metal, except where otherwise specified. Linear dimensions in millimeters. Tolerances on dimensions without specific tolerance: On angles: +0' / -10' On linear dimensions: when <25mm: +0mm / -0.05mm when >25mm: ±0.2mm Both joints shall permit movement in the same plane and the same direction through an angle of 90 degrees with a 0 to +10 degrees tolerance.</p>	<p>10N ± 10%</p>

3.15.8.2.1.2 When checking the contact of the test probe with high-voltage live parts inside the electrical barriers, enclosures, etc. by a signal indication circuit method, a low voltage power supply (of not less than 40 V and not more than 50 V) in series with a suitable lamp shall be connected between the test probe and high-voltage live parts.

3.15.8.2.1.3 Additionally, when a signal indication circuit method is used, the parts prescribed in Section 3.15.8.1.1 and 3.15.8.1.2 above shall be covered with a conductive metallic film before the collision test and the metallic film shall be electrically connected to normal high-voltage live parts.

3.15.8.3 Test Method

3.15.8.3.1 Press the test probe against an opening of the electrical barriers, enclosures, etc. (meaning any gaps or openings in the electrical barriers, enclosures, etc. that are already present or that might be made when the test probe is pressed against them with the prescribed force) with the force prescribed in the "Test Force" column in Table 1.

3.15.8.3.2 If possible, the movable parts inside the enclosure shall be moved slowly.

3.15.8.3.3 If the test probe partially or fully penetrates into the opening, the probe shall be placed in every position that can be touched to check whether it can be touched or not (whether the lamp lights if the signal indicator lamp method is used; the same shall apply hereinafter in this Attachment). In such cases, starting from the straight position, both joints of the test finger shall be rotated progressively through an angle of 90 degrees with respect to the axis of the adjoining section of the finger and placed in every possible position to check whether it can touch them.

3.15.8.4 Criteria

3.15.8.4.1 The test probe shall not be able to contact high-voltage live parts.

3.15.8.4.2 The stop face of the test probe shall not be able to fully penetrate into the electrical protection barriers or enclosures through any opening.

3.15.8.4.3 When checking for contact by the signal indicator circuit method, the lamp shall not light.

3.15.9 Measurement of Isolation Resistance

Isolation resistance is measured by choosing the method prescribed in Section 3.15.9.1 and 3.15.9.2 below as appropriate depending on the state of electric charge or isolation resistance of the live parts to be measured.

The range of electric circuits to be measured shall be clarified by submitting circuit drawings, etc. to TNCAP and the technical service in advance.

Additionally, modifications necessary for measuring the isolation resistance may be made as appropriate such as removing the cover, extracting measuring lines, and modifying software programs. When conducting the measurements, care shall be taken regarding the risk of short circuiting and electric shock because the method involves directly handling high-voltage circuits.

3.15.9.1 Measuring by Applying Direct Current from Outside

3.15.9.1.1 Measuring Tools: To measure the isolation resistance, an isolation resistance tester that can apply a direct current higher than the working voltage of high-voltage circuits shall be used.

3.15.9.1.2 Measuring Method

3.15.9.1.2.1 Connect an isolation resistance tester between the live parts and the electrical chassis or exposed conductive parts and apply a direct current higher than the working voltage of the high-voltage circuits; provided, however, that if parts may be damaged by overvoltage during measurement because the external direct current is combined with the voltage of the rechargeable energy storage system (REESS) or the isolation resistance tester cannot apply an appropriate voltage due to its properties, etc., measurements may be taken at a voltage lower than the working voltage or by removing relevant parts.

3.15.9.1.2.2 If measurement of the live parts of electric circuits to be measured shows that the requirement for isolation resistance is satisfied even taking the rechargeable energy storage system (REESS) into account or if the live parts to be measured are not charged, such measured values are regarded as values of isolation resistance. If the live parts to be measured are charged and the measured values do not satisfy the requirement for isolation resistance or the values of isolation resistance when the voltage of the REESS is taken into account do not satisfy the required isolation resistance, isolation resistance shall be measured by the method prescribed in Section 3.15.9.2.

3.15.9.2 Measurement Using Internal Power Supply for Direct Current: The isolation resistance between live parts (high-voltage bus) and the electrical chassis can be demonstrated either by measurement or by a combination of measurement and calculation.

3.15.9.2.1 When demonstrating isolation resistance by measurement, do the following:

3.15.9.2.1.1 Measure and record voltage (V_b) between the negative side and the positive side of the high-voltage bus. (See Figure 2)

3.15.9.2.1.2 Measure and record voltage (V_1) between the negative side of the high-voltage bus and electrical chassis. (See Figure 2)

3.15.9.2.1.3 Measure and record voltage (V_2) between the positive side of the high-voltage bus and the electrical chassis. (See Figure 2)

3.15.9.2.1.4 If V_1 is greater than or equal to V_2

3.15.9.2.1.4.1 Insert a standard known resistance (R_o) between the negative side of the high-voltage bus and the electrical chassis. With R_o installed, measure the voltage (V_1') between the negative side

of the high-voltage bus and the vehicle electrical chassis. (See Figure 2)

Calculate the insulation resistance (R_i) using the formula:

$$R_i = R_o \times (V_b/V_1' - V_b/V_1) \text{ or}$$

$$R_i = R_o \times V_b \times (1/V_1' - 1/V_1)$$

3.15.9.2.1.4.2 Divide the result R_i , which is the electrical isolation resistance value in units of Ω , by the working voltage of the high-voltage bus in units of volt (V).

$$R_i (\Omega / V) = R_i (\Omega) / \text{Working Voltage (V)}$$

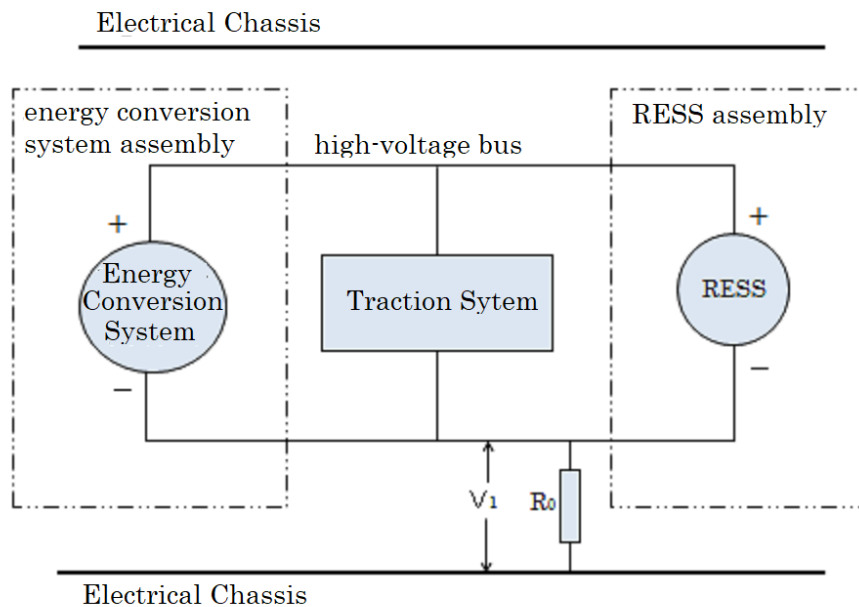

Figure 2: Measurement of V_1'

3.15.9.2.1.5 If V_2 is greater than V_1

3.15.9.2.1.5.1 Insert a standard known resistance (R_o) between the positive side of the high-voltage bus and the electrical chassis. With R_o installed, measure the voltage (V_2') between the positive side of the high-voltage bus and the vehicle electrical chassis (see Figure 3).

Calculate the insulation resistance (R_i) using the formula:

$$R_i = R_o \times (V_b/V_2' - V_b/V_2) \text{ or}$$

$$R_i = R_o \times V_b \times (1/V_2' - 1/V_2)$$

3.15.9.2.1.5.2 Divide the result R_i , which is the electrical isolation resistance value in units of Ω , by the working voltage of the high-voltage bus in units of volt (V).

$$R_i (\Omega / V) = R_i (\Omega) / \text{Working Voltage (V)}$$

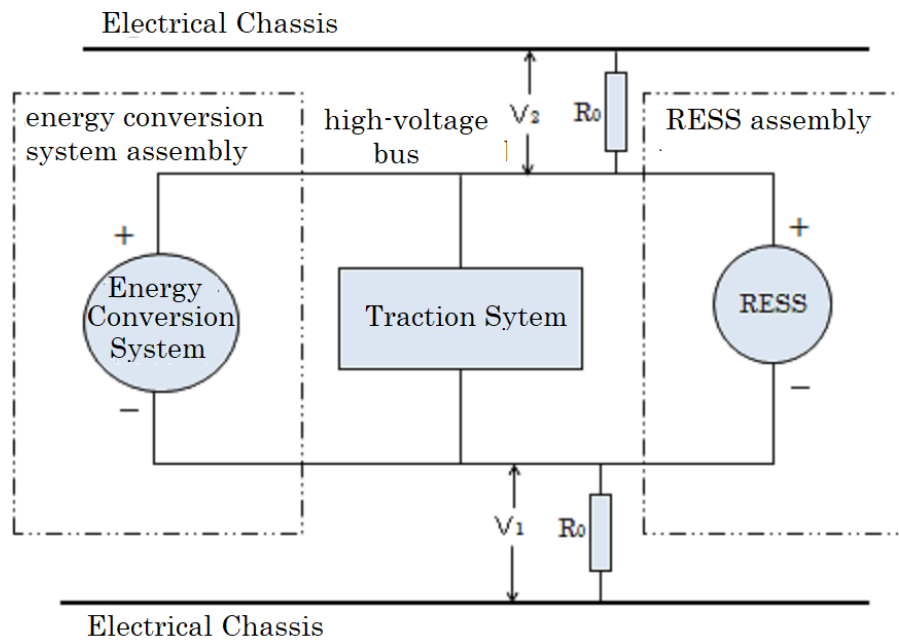

Note 1: Standard known resistance R_0 (in units of Ω) is the value obtained by multiplying the minimum value of the required isolation resistance by the working voltage of the vehicle (in units of Ω/V) $\pm 20\%$. Since this equation is valid for any R_0 , R_0 does not have to be strictly this value, but this range of R_0 value provides a good resolution for voltage measurement.

Figure 3: Measurement of V_2 '

3.15.10 Measurement of Residual Voltage

After the collision test, measure the voltages of the high-voltage bus (V_b , V_1 , V_2) (see Figure 4). Voltage is measured at a point in time between 5 seconds and 60 seconds after the collision.

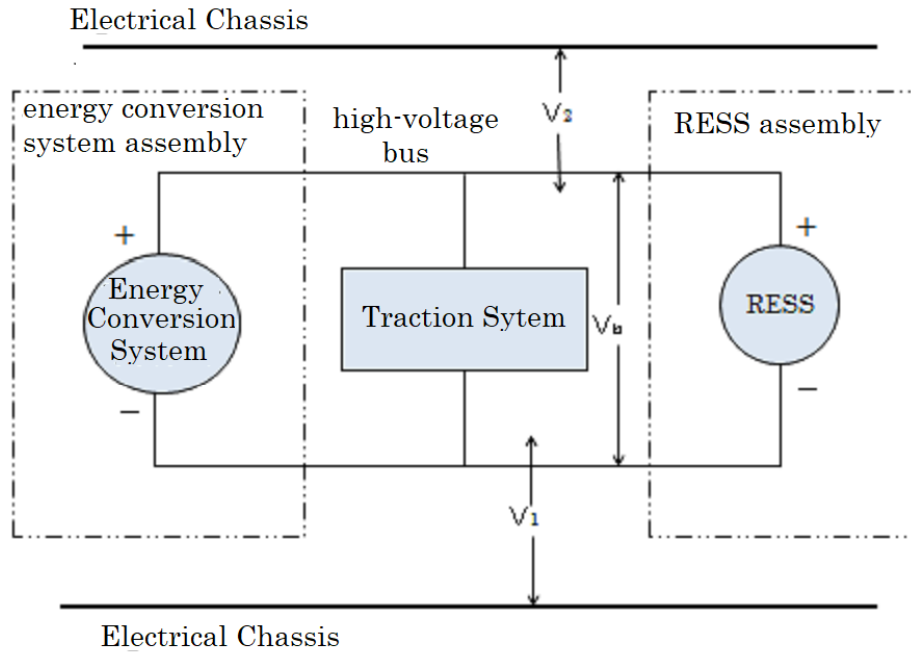

Figure 4: Measurement of V_b, V₁, and V₂

3.15.11 Measuring Residual Energy

Before conducting the collision test, connect switch S₁ and a known discharge resistance R_e with an appropriate capacitance in parallel (See Figure 5).

Close the switch S₁ at a point in time between 5 seconds and 60 seconds after the collision and measure and record voltage V_b and current I_e. Integrate the product of the voltage V_b and current I_e over the time elapsed between the moment switch S₁ is closed (t_c) and the moment voltage V_b falls below the high-voltage threshold 60 V DC (t_h).

$$(1) \quad TE = \int_{t_c}^{t_h} V_b \times I_e dt$$

When V_b is measured at a point in time between 5 seconds and 60 seconds after the collision and the capacitance of condenser X (C_x) is prescribed by the manufacturer, the total energy (TE) is calculated by the following formula:

$$(2) \quad TE = 0.5 \times C_x \times (V_b^2 - 3,600)$$

When V₁ and V₂ (see Figure 5) are measured at a point in time between 5 seconds and 60 seconds after the collision and the capacitance of condenser Y (C_{y1}, C_{y2}) is prescribed by the manufacturer, the total energy (TE_{y1}, TE_{y2}) is calculated by the following formula:

$$(3) \quad \begin{aligned} TE_{y1} &= 0.5 \times C_{y1} \times (V_1^2 - 3,600) \\ TE_{y2} &= 0.5 \times C_{y2} \times (V_2^2 - 3,600) \end{aligned}$$

Electrical Chassis

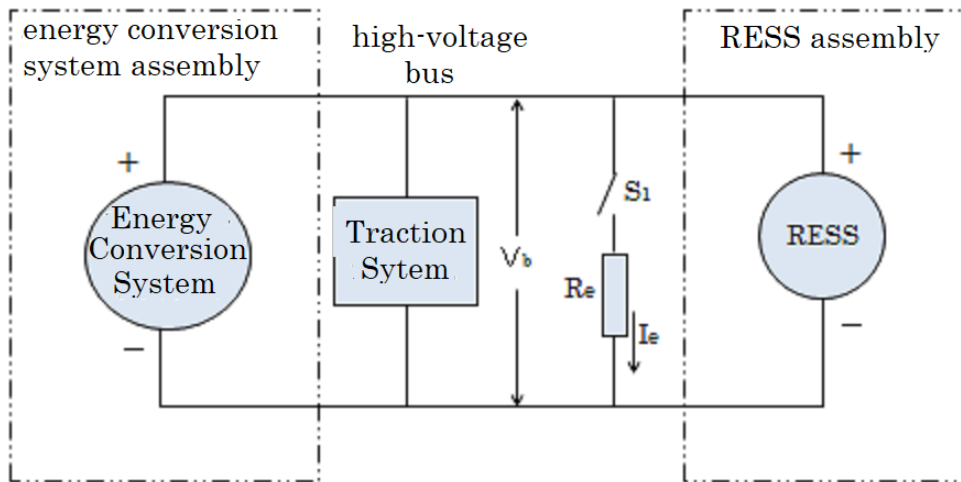

Electrical Chassis

Figure 5: Measurement of high-voltage bus energy stored in condenser X