

**Ministry of Transportation and
Communications**

**Taiwan New Car Assessment Program
(TNCAP)**

Second Version

3.5 Front Whiplash Testing Protocol

V2.1
Apr 2025

TABLE OF CONTENTS

3.5.1 Definitions.....	3
3.5.2 Coordinate System	4
3.5.3 Sled Seat Mounting and Positioning.....	5
3.5.4 H-Point Machine (HPM) & Dummy Positioning H	14
3.5.5 Head Restraint Positions	18
3.5.6 BioRID ATD Requirements	28
3.5.7 Test Sled Requirements.....	32
3.5.8 Test Sled Instrumentation.....	32
3.5.9 Whiplash Assessment Criteria	33
3.5.10 Manufacturer’s Specified Settings	39
3.5.11 RCAR GLORIA Jig & Calibration Procedure (HPM/HRMD Calibration)	40
3.5.12 Preliminary Adjustments to the HRMD and H-Point Machine	50
3.5.13 Sled pulse specification.....	51
3.5.14 Seat Movement Definitions	56

3.5.1 Definitions

- 3.5.1.1 Head Restraint: A device designed to limit the rearward displacement of an adult occupant's head in relation to the torso in order to reduce the risk of injury to the neck in the event of a rear impact.
- 3.5.1.1.1 Integrated Head Restraint or Fixed Head Restraint: A head restraint formed by the upper part of the seat back, or a head restraint that is not height adjustable and/or cannot be detached from the seat or the vehicle structure except by the use of tools or following the partial or total removal of the seat furnishings.
- 3.5.1.1.2 Adjustable Head Restraint: A head restraint that is capable of being positioned to fit the anthropometry of the seated occupant. The device may permit horizontal displacement, referred to as "tilt" adjustment and/or vertical displacement, known as "height" adjustment.
- 3.5.1.1.3 Re-active Head Restraint: A device designed to improve head restraint geometry during an impact. It will usually be deployed by the occupant's mass within the seat operating a mechanism during the crash. They also usually re-set after loading to a pre-accident condition.
- 3.5.1.1.4 Pro-active Head Restraint: A device designed to automatically improve head restraint geometry prior to an impact, which utilizes sensors to trigger pyrotechnics, magnetic or other device to release stored energy in order to deploy head restraint or seatback elements. Such systems require no input from the occupant to operate. They are usually not re-settable following a deployment and remain in their deployed state.
- 3.5.1.1.5 Automatically Adjusting Head Restraint: A head restraint that automatically adjusts its position depending on the stature of the seated occupant.
- 3.5.1.1.6 Locking: An adjustable head restraint fitted with a device to prevent inadvertent downward or rearward movement from its adjusted position, i.e. when a rear seat occupant uses a front seat head restraint as a hand hold to facilitate easy entry or exit from the vehicle. A locking device may be fitted to both the horizontal and vertical adjustments of the head restraint. A locking device shall incorporate a mechanism that requires intervention to allow downward/rearward head restraint adjustment after which the mechanism shall re-engage automatically.
- 3.5.1.2 H-Point Manikin (HPM): The device used for the determination of "H" points and actual torso angles. (SAE Standard J826, SAE Handbook, Vol 3, 1999) modified according to the Insurance Corporation of British Columbia (ICBC) Instruction Manual for the HRMD, see section 3.5.12.

3.5.1.3 Head Restraint Measuring Device (HRMD): A separate head-shaped device used with the H-point machine to measure the static geometry of a vehicle head restraint. It was developed under the sponsorship of the Insurance Corporation of British Columbia (ICBC)-(SAE paper 1999-01-0639). The HRMD is equipped with two probes to measure head restraint height and backset. The height probe projects horizontally, level with the top of the head, to provide a reference line for the vertical measurement to the top of the restraint. The backset probe simulates the rear profile of the head and neck and projects horizontally, to provide the horizontal measurement to the restraint.

3.5.1.3.1 HRMD Height: This is defined as the vertical measurement between the height probe of the HRMD and the top of the head restraint.

3.5.1.3.2 HRMD Backset: This is defined as the horizontal measurement between the back surface of the HRMD head and the front surface of the head restraint as measured by the backset probe of the HRMD.

3.5.1.3.3 BioRID Reference Backset: This is derived from the horizontal measurement between the back surface of the HRMD and the selected reference point on the front surface of the head restraint. The BioRID Reference Backset is 15 mm greater than the HRMD backset and will be used to position the dummy prior to test.

3.5.1.3.4 BioRID Backset is defined as the horizontal measurement between the back surface of the BioRID head and the selected reference point on the front surface of the head restraint.

3.5.1.4 Seat Movement Definitions: For an illustration of seat movement definitions, see section 3.5.14.

3.5.2 Coordinate System

3.5.2.1 Sled Coordinates

3.5.2.1.1 The coordinate system used must be an ordinary Cartesian co-ordinate system with 90° between the axes.

3.5.2.1.2 The origin for all measurements made using CMM is to be located on the upper surface of a seat mounting bolt hole, in the stationary part of the seat runner. This common origin will provide a means of comparing seat positions across technical service, where required. In the first instance, the right hand rear mounting hole shall be used. If this is not present, the next available fixation point shall be chosen, considering available options in the following order: left hand rear, left hand front, right hand front.

3.5.2.2 Dummy Coordinates

3.5.2.2.1 The coordinate system for the BioRID instrumentation used must be in accordance with SAE J211.

3.5.3 Sled Seat Mounting and Positioning

For the base seat setup specifications used in section 3.5.3.2 to 3.5.3.5, manufacturers will be requested to provide data listed in 3.5.10 prior to test preparation. Alternatively, physical vehicle measurements may be used. In all cases the vehicle shall be placed on level ground with no occupant load and a full tank of fuel. Ensure that the vehicle has its spare wheel and all tools supplied on board and all tyre pressures set to manufacturer's recommendations. For vehicles with active suspension and/or automatic levelling the suspension shall be set to a driving speed of 40km/h in normal running conditions as specified by the manufacturer.

All base seat setup specifications must be achieved within 0.2° and 5mm of linear tolerance, with the exception of seat belt attachments. Please refer to section 3.5.5.2 for details on the correct location.

Due to the BioRID dummy's unsuitability for more upright seating positions, heavy vehicles (as defined in section 1.4) are exempt from dynamic testing and are not subject to this protocol.

3.5.3.1 Packaging Issues

3.5.3.1.1 TNCAP executive agency reserves the right to refuse the sled testing of a seat where the performance of the seat or head restraint could be influenced by the vehicle environment or packaging. There shall be no stiff structure in the vicinity of the head restraint that could be contacted by the head in a rear impact or that could influence the dynamic deflection of the seat back. There shall be no additional support for the seat back that is not present in the sled test set-up.

3.5.3.1.2 Where such circumstances exist, for example with 2 seater sports cars, the vehicle manufacturer may be offered the opportunity to test with a body-in-white or to simulate all relevant structures on the sled set-up. The additional test costs and provision of a body-in-white shall be paid for by the manufacturer in these circumstances.

3.5.3.1.3 The mid track seat position shall allow a seat back angle of 25 degrees adjustment in all cases. Where a bulkhead or similar structure prevents this, the seat track shall be adjusted forward until 25 degrees is achieved.

3.5.3.2 Seat Structure Reference Point

In addition to the coordinate system origin determined in 3.5.2.1.2, a further seat structure reference point shall also be chosen. This is defined as a fixed point on the seat structure which stays in the same position relative to the vehicle, independent of any seat adjustment. Record (with a photograph) the location used

and ensure that this is consistent between vehicle and sled measurements for a particular seat.

For vehicle manufacturers sourced seat setups, this reference point must also be specified. Figure 1

Figure 1 shows an example seat reference point being the front left bolt hole, but other non-moving parts of the seat mounting structure are acceptable. The seat structure reference point shall be chosen such that the relationship of the seat to the vehicle floor can be accurately reproduced on the sled.



Figure 1: Definition of the Seat reference point

3.5.3.3 Toe Board

The toe board is defined as a simulated floor and toe pan, consisting of a horizontal section sufficiently large to rest the dummy's feet and connected to a section oriented 45° from the horizontal. When positioned for test, the gap between the front of the seat and rear of the toe board shall be no more than 100mm. Both surfaces shall be covered with short-piled carpet. A suitable arrangement is illustrated in Figure 2.

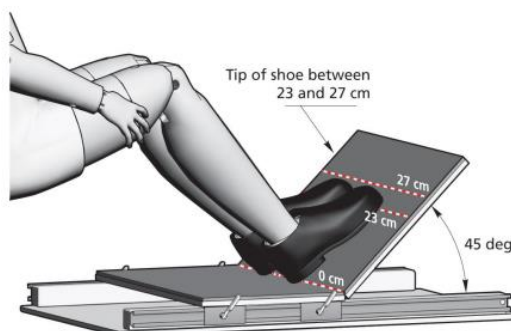

Figure 2 Toe board arrangement showing correct positioning of BioRID feet

3.5.3.4 Heel surface

The heel surface is defined as the horizontal plane of the toe board (i.e. sled floor)

or movable footrest) on which the dummy's heel rests. Its target position is determined using the heel rest point location defined from the vehicle measurements, or from information provided by the vehicle manufacturer. An accurate height setting shall be obtained at this stage; however an initial approximated horizontal position may be set. The final horizontal position will be obtained in section 3.5.5.6.8.

3.5.3.4.1 Heel Rest Point Location

3.5.3.4.1.1 Determine heel rest point location

Determine the heel rest point location. The heel rest point location is defined in the vehicle (with removable floor mats not fitted) by using the accelerator pedal as the steps outlined in 3.5.3.4.1.2.

3.5.3.4.1.2 Find the geometric centre point of the accelerator pedal contact surface (both laterally and vertically). Place a straight edge between the accelerator pedal centre point and the fixed carpeting on the vehicle floor such that the straight edge is tangential to the accelerator pedal surface at the centre point. The heel rest point location is then the contact point of the straight edge on the vehicle floor, see Figure 3.

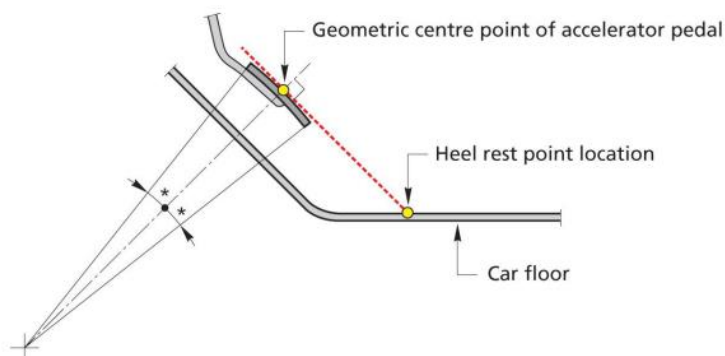

Figure 3 Heel rest point

3.5.3.5 Seat Mounting to Sled

3.5.3.5.1 The seat, including all of its adjustment mechanisms and hardware that normally connects it to the vehicle floor (e.g. longitudinal adjustment rails), shall be securely fastened to the test sled platform.

3.5.3.5.2 The attachment shall be made so that the seat's orientation relative to the horizontal is the same as it would be in its vehicle as defined by physical vehicle measurements or vehicle manufacturer data. The actual height of the seat from the sled platform may be different from its height above the vehicle floor.

3.5.3.5.3 The toe board is also attached to the sled platform. The horizontal floor portion shall be mounted at the same height relative to the seat bolts/rails

as the heel rest point. The fore/aft position of the toe board shall be adjustable. Figure 4 shows an example seat both in-vehicle and mounted on the sled platform.

3.5.3.5.4 The seat structure reference, seat rail angle and heel rest point shall be recorded in the test report. Seat mounts shall be rigid and non-deformable, and the seat mount interface to the seat shall approximate that of the interface to the vehicle floor. The vehicle manufacturer will be asked to provide details of the relevant seat mounting measurements/tolerances and will be invited to examine the fixture prior to test. Alternatively, the car manufacturer may provide the technical service with a suitable seat attachment frame or fixture.



Figure 4 Attachment of seat to test sled

3.5.3.6 Seat Position

3.5.3.6.1 Seats with Automatically Adjusting Head Restraints

The BioRID dummy used for these dynamic tests represents a midsize adult male driver or vehicle occupant. Consequently, seats equipped with head restraints that automatically adjust depending on other seat adjustments (e.g. seat track or height) shall be set to a position most likely to be used by a seat occupant of the same size as the dummy. Therefore, the seat shall be adjusted to its mid track and mid height position.

Since the seat's starting position can affect the final position of the head restraint, a consistent setup sequence shall be followed. During setting of the mid/mid position, the seat shall always be moved rearward from the forward most position, and downward from the fully up position. The seatback shall then be positioned following the procedure in section 3.5.4.3. All other seat settings that have not already been adjusted shall be set according 3.5.3.6.2.

3.5.3.6.2 Setting manual seat adjustments

The various seat adjustments possible on many modern vehicle seats shall be set according to the following instructions. Because the setting of some adjustments may affect the adjustment range of other adjustments, the seat shall

be set by following the order of the procedure outlined here. If the seat is new and has never been sat on, a person of mass $75\text{kg} \pm 10\text{kg}$ shall sit on the seat for 1 minute, twice, to flex the cushions. The seat shall have been at room temperature for at least six hours and not loaded for at least one hour previous to the initial installation of the H-point manikin. Following this pre-conditioning, the seat set up may be undertaken. The seatback angle will be set in section 3.5.4.3, the initial setting is not important so long as it doesn't interfere with other adjustments.

Seat adjustments shall now be set using the sequence described in section 3.5.3.6.2.1 to 3.5.3.6.2.7. Subsequent seat adjustments may affect the original position of a previous setting. If this is the case there shall be no re-adjustment of the previous settings.

3.5.3.6.2.1 Initial Adjustment of Seat Adjustment Controls

All seat controls shall be set in sequence as follows. Section 3.5.14 provides more detailed descriptions with illustration of each of these seat adjustments.

- (1) Seat track shall be in its most rearward locking position.
- (2) Seat height shall be set to its lowest position.
- (3) Seat tilt shall be set to the extreme of its range that puts the cushion angle closest to zero (horizontal). Section 3.5.3.6.2.2 describes the method for measuring the cushion angle.
- (4) Cushion height shall be set to its lowest position.
- (5) Cushion tilt shall be set to the extreme of its range that puts the cushion angle closest to zero (horizontal). Section 3.5.3.6.2.2 describes the method for measuring the cushion angle.
- (6) Lumbar support shall be set to its most rearward or least prominent position.
- (7) Upper seat back, if separately adjustable from the lower portion shall be rotated fully rearward.
- (8) Cushion extension shall be set to its most rearward or least extended position.
- (9) Side bolsters shall be set to the widest position.
- (10) Arm Rests shall be set in the stowed position.

3.5.3.6.2.2 Measurement of Cushion Angle

Locate and mark a point on the forward edge of the top surface of the seat cushion and midway between the right and left edges of the cushion. Locate, mark, and record a second point that is 400mm rearward along a line parallel to the direction of the sled movement. The cushion angle is the reading from a digital protractor sitting on the surface of the seat with the rearmost end on

the rear seat mark. A suitable length protractor shall be chosen such as the entire length of its underside (measurement surface) is in contact with the central panel of the seat cushion. The angle measurement shall not be influenced by padding or bolstering on the front of the seat base.

Alternatively, if a coordinate measurement machine (CMM) is used to record the locations of the seat marks, then the Sine of the cushion angle is the difference in the Z-coordinates (in mm) of these 2 points (first minus second) divided by 400mm. See Figure 5.

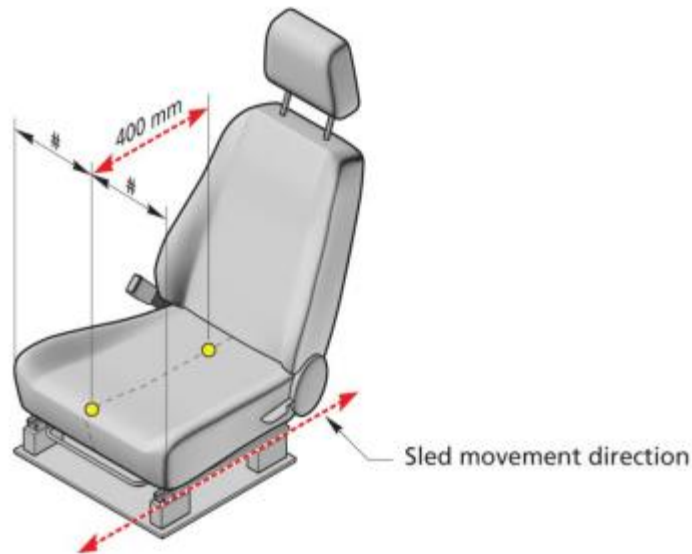

Figure 5 Measurement of cushion angle

3.5.3.6.2.3 Setting Seat Track Adjustment to Midrange

Mark both sides of the seat track and adjacent portion of the seat support structure. Move the seat to its most forward most locking adjustment position and mark the seat track adjacent to the repositioned marks on either side of the seat support structure. On both sides of the seat, measure the distance between the two seat track marks and mark the track midway between the first two marks.

Alternatively, a CMM may be used. With the seat in the rearmost position, mark a hard point on the seat and record its location.

Move the seat to its most forward adjustment position and record the position of the seat hard point. Move the seat rearward until the mark on the seat support structure aligns with centre seat track mark, or until the marked hard point is midway between the two previously recorded hard point locations. The final position will depend on whether the seat track adjusts continuously or incrementally.

The seat shall be checked to ensure that both seat runners are set and locked correctly. In some cases there may be different amounts of travel between the

two seat runners, care shall be taken to ensure that in such cases both seat runners are locked in the correct positions.

3.5.3.6.2.3.1 Continuously Adjusting Seat Track

The seat mark shall align ($\pm 2\text{mm}$) with the mid-track mark. Alternatively, the hard point shall have an X-coordinate that is midway ($\pm 2\text{mm}$) between the X-coordinates of the forward most and rearward most adjustment positions.

3.5.3.6.2.3.2 Incrementally Adjusting seat Track

If the midrange adjustment does not correspond to an incremental adjustment position ($\pm 2\text{mm}$), then the seat shall be set to the first incremental position rearward of the calculated midrange position.

3.5.3.6.2.4 Setting Seat Height Adjustment to Midrange

Mark two hard points on the side of the seat, which are attached to and move with the cushion frame, one near the front of the cushion and one near the rear. Record the locations of both points with a CMM or measure the vertical heights of the points relative to a fixed reference with a measuring tape. Use the seat height adjuster control(s) to move the seat to its highest position. If the front and rear of the seat adjust separately, then make sure that both the front and rear of the seat are raised to their highest positions.

Record the locations of the two hard points with the CMM or measure the vertical heights of the points relative to a fixed reference with a measuring tape. Then lower the seat until both hard points are midway between their highest and lowest positions. The final position will depend on type of seat height adjuster.

3.5.3.6.2.4.1 Single Control Seat Height

If the height is controlled by a single adjuster, its final position will depend on whether it is continuously or incrementally adjusting.

3.5.3.6.2.4.1.1 Continuously Adjusting seat Height

For single control height adjusters, the rear hard point shall be $\pm 2\text{mm}$ of the calculated midpoint.

3.5.3.6.2.4.1.2 Incrementally Adjusting Seat Height

If the midrange adjustment does not correspond to an indexed adjustment position ($\pm 2\text{mm}$), then the seat shall be set to the first indexed position below the calculated midrange position.

3.5.3.6.2.4.2 Dual control seat height

If the front and rear of the seat adjust separately, then use the front adjuster to lower the front hard point and the rear adjuster to lower the rear hard point. The final position will depend on whether it is continuously or

incrementally adjusting. Note that the adjustment of the front and rear controls may need to be iterated in order to achieve the calculated midpoints.

3.5.3.6.2.4.2.1 Continuously Adjusting Seat Height

Both hard points shall be $\pm 2\text{mm}$ of the calculated midpoints. If this is not possible, then the rear hard point shall be $\pm 2\text{mm}$ of the calculated midpoint and the front hard point as close to the calculated midpoint as possible.

3.5.3.6.2.4.2.2 Indexed Adjusting Seat Height

If either midrange adjustment does not correspond to an indexed adjustment position ($\pm 2\text{mm}$), then it shall be set to the first indexed position below the calculated midrange position for the corresponding seat hard point.

3.5.3.6.2.5 Setting Cushion Height Adjustment

The cushion height adjustment uses the points marked on the top surface of the cushion in section 3.5.3.6.2.2.

3.5.3.6.2.5.1 Single Control Cushion Height Adjustment

Raise the cushion to its highest adjustment and record the position of the rear cushion point (400mm behind front edge point). Lower the seat cushion to its mid-position. The final position will depend on whether it is continuously or incrementally adjusting.

3.5.3.6.2.5.1.1 Continuously Adjusting Seats

The rear cushion point shall have a Z-coordinate midway ($\pm 2\text{mm}$) between the lowest (initial) and highest positions.

3.5.3.6.2.5.1.2 Incrementally adjusting seats

If the midrange adjustment does not correspond to an indexed adjustment position ($\pm 2\text{mm}$), then the seat cushion height shall be set to the first indexed position below midrange.

3.5.3.6.2.5.2 Dual control cushion height adjustment

Use the rear cushion height adjuster to raise the rear of the cushion to its highest position and record the location of the rear cushion point (400 mm behind front edge point). Again using the rear cushion height adjuster, lower the rear of the cushion so that the rear cushion point is midway between the lowest (initial) and highest positions. Use the front cushion height adjuster to raise the front of the cushion until the cushion angle matches the angle recorded in step 3.5.3.6.2.2. The final position will depend on whether it is continuously or incrementally adjusting. Note that the adjustment of the front and rear controls may need to be iterated in

order to achieve the calculated midpoints.

3.5.3.6.2.5.2.1 Continuously Adjusting Seat Height

The rear seat point Z-coordinate shall be $\pm 2\text{mm}$ of the calculated midpoint and the cushion angle shall match that recorded in step 3.5.3.6.2.2 to within ($\pm 0.5^\circ$).

3.5.3.6.2.5.2.2 Indexed Adjusting Seat Height

If the midrange adjustment of the rear adjuster does not correspond to an indexed adjustment position, then it shall be set to the first indexed position below the calculated midrange. Likewise, if the cushion angle from 3.5.3.6.2.2 cannot be matched ($\pm 0.5^\circ$) with the front adjuster adjusted to an indexed position, then set the front adjuster to the next lowest indexed position.

3.5.3.6.2.6 Adjusting Upper Seatback Angle

Measure the angle relative to vertical of the head restraint support post or some flat part of the seatback frame. Without changing the adjustment of the lower seatback, move the upper seatback to its most forward position and measure the angle of the head restraint post or seatback frame. Adjust the upper seatback rearward until the head restraint post or seatback frame angle is midway ($\pm 0.5^\circ$) between the rearmost and forward most angles.

3.5.3.6.2.7 Other Seat Adjustments

Seat adjustments not set in steps 3.5.3.6.2.2 through 3.5.3.6.2.6 shall remain in the initial adjustment as set in section 3.5.3.6.2.1.

3.5.3.7 Seat Belt

3.5.3.7.1 A generic three point lap-shoulder seat belt equipped with an inertia reel shall be used during the test, placed in such a way that the belt, when worn by the ATD, shall lie across the torso, clavicle and pelvis, and must always be routed above the pelvic angle gauge.

3.5.3.7.2 For generic seat belts, where a seat is equipped with anchorages or buckles, these may be used. Any anchorages not attached to the seat shall be positioned as shown in Figure 6. The marks, which correspond to the arrangement of the anchorages, show where the ends of the belt are to be connected to the sled. The anchorages are the points A, B and K. The tolerance on the position of the anchorage points is such that each anchorage point shall be situated at most at 50mm from corresponding points A, B and K indicated in Figure 6.

3.5.3.7.3 If a fourth anchorage is necessary to attach the retractor, this anchorage:

- (1) shall be located in the vertical longitudinal plane passing through K,
- (2) shall be located 770mm vertically below K.

In the case of a belt equipped with a belt adjustment device for height, this device shall be secured to a rigid frame.

3.5.3.7.4 The structure carrying the anchorages must be rigid and shall be so constructed that no permanent deformation shall occur in the parts bearing the anchorages during the test.

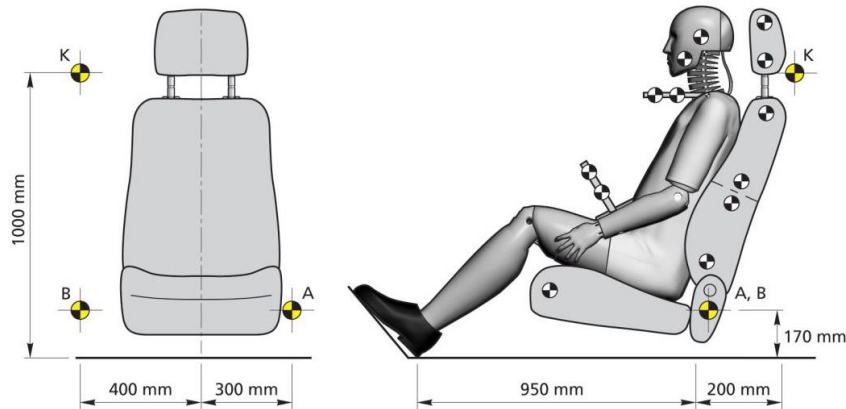

Figure 6 Generic seat belt anchorage mounting

3.5.3.7.5 Where a manufacturer requests and can demonstrate good reason for doing so to the TNCAP executive agency, vehicle specific belts and geometry may be considered. In this case or when testing seats equipped with integrated belts the vehicles own seat belt hardware (retractor and buckle) shall be used. Seat belt geometry and restraint equipment shall then be used that approximates that of the test vehicle. Where this is agreed, the vehicle manufacturer will be asked to provide details of the relevant mounting measurements/tolerances and will be invited to examine the fixture prior to test. Alternatively, the car manufacturer may provide the technical service with an attachment frame or fixture.

3.5.3.8 Triggering of active elements

For each seat it shall be ascertained from manufacturer data whether active elements (e.g. pro-active head restraint or seat belt pretensioner) are fitted, and whether they would be triggered for each of the test pulses. For each element which requires a trigger, Time to Fire (TTF) shall be specified by the vehicle manufacturer for each pulse if required. Supporting data shall be provided by the manufacturer to show that the system always triggers throughout the entire range of rear impact scenarios considered by TNCAP. For example, the low severity RCAR bumper test would be considered.

3.5.4 H-Point Machine (HPM) & Dummy Positioning H

3.5.4.1 Introduction

The following section contains the current positioning procedure for use with the BioRID dummy. The entire process for a single installation and measurement

using the HPM and HRMD shall last approximately 15 minutes maximum per installation.

3.5.4.2 H-point Manikin and HRMD Preparation

The BioRID test position is based on reference measurements made with the H-point manikin (HPM) and HRMD. Parts of the following text contain excerpts from “A Procedure for Evaluating Motor Vehicle Head Restraints” (Issue 2, RCAR, February 2001). A specific pairing of manikin and HRMD must be used which have been certified together. Before using the combination, ensure that the build condition is correct. Remove the head room probe from the H-point machine and install the two washers (supplied with the HRMD) in the spaces remaining on the H-point pivot. The fit of the HRMD on the H-point machine shall be confirmed. Lower the HRMD in position onto the torso weight hangers and onto the top edge of the channel between the torso weight hangers. Ensure that the HRMD fits easily into place without inducing forces which might disturb the manikin position.

3.5.4.3 H-point Manikin Installation

3.5.4.3.1 The seat shall be covered with a cotton cloth large enough to cover both cushions and seatback.

3.5.4.3.2 The cloth shall be tucked into the seat joint by an amount sufficient to prevent hammocking of the material.

3.5.4.3.3 The H-point manikin shall be installed in the seat.

3.5.4.3.4 The lower legs shall be adjusted to the 50th percentile leg length setting, and the upper legs shall be adjusted to the 10th percentile leg length setting; these are the HPM settings closest to the TNCAP front and side impact protocol settings.

3.5.4.3.5 The legs shall be attached to the HPM and set to the 5th position (no.5) on the knee joint T-bar, which places the knees 250mm apart.

3.5.4.3.6 With the legs attached and the back pan tilted forward, the HPM shall be positioned in the seat such that its mid-sagittal plane coincides with the longitudinal centreline of the seat. The centreline of the seat may be defined from features such as the head restraint support tubes or seatback and seat pan side bolsters. Particular attention shall be paid to seats with asymmetric design.

3.5.4.3.7 The back pan shall be straightened to conform to the vehicle seat back.

3.5.4.3.8 The feet shall be placed as far forward as possible, with the heels resting on the heel plane and the feet positioned at 90° to the tibias. The toe pan shall be positioned sufficiently far away so as to avoid any interaction with the feet during the HPM installation process.

3.5.4.3.9 The lower leg and thigh weights shall be attached to the HPM and the

assembly shall be levelled.

- 3.5.4.3.10 The back pan shall be tilted forward to 45° from the seat back and the HPM assembly pushed rearward until the seat pan contacts the vehicle seat back. While maintaining the back pan at 45° to the seat back, a horizontal rearward force of 100N shall be applied using the plunger if present or using a force gauge pressed against the hip angle quadrant structure.
- 3.5.4.3.11 The load application shall be repeated and, while keeping the 100N applied, the back pan shall be returned to the vehicle seat back and the load then released. As the 100N is released, a small force shall be maintained on the front of the T-bar to prevent any longitudinal movement. This support shall be maintained until the end of section 3.5.4.3.17 is reached.
- 3.5.4.3.12 A check shall be made to determine that the HPM is level, facing directly forward, and located in the centreline of the seat.
- 3.5.4.3.13 As an approximation of the vehicle seat back position, it shall be placed such that the torso angle is about 21° before the buttock and chest weights are added. This angle may be varied according to the subjective estimate of the seat cushion stiffness or based on data provided by the manufacturer.
- 3.5.4.3.14 The HPM torso angle shall be measured by placing an inclinometer on the calibrated block (see 3.5.11) located on the lower brace of the torso weight hanger.
- 3.5.4.3.15 After estimating the vehicle seat back position, the right and left buttock weights shall be installed. The six chest weights (including the two larger weights) shall be installed by alternating left to right. The two larger HRMD chest weights shall be attached last, flat side down. Throughout the weight installation, maintain a light pressure to the T-bar preventing any longitudinal movement.
- 3.5.4.3.16 Tilting the back pan forward to a vertical position, the assembly shall be rocked from side to side over a 10° arc, 5° in each direction. Where seat side bolsters prevent movement of up to 5°, the assembly shall be rocked as far as permissible. This rocking shall be repeated twice, making a total of three complete cycles. Care shall be taken to maintain support of the T-bar during the rocking action, and to ensure that no inadvertent exterior loads are applied. Ensure that the movements of the HPM feet not restricted during this step. If the feet change position, they shall be allowed to remain in that attitude for the time being.

- 3.5.4.3.17 Holding the T-bar to prevent the HPM from sliding forward on the seat cushion, the back pan shall be returned to the vehicle seat back, and the HPM shall be levelled.
- 3.5.4.3.18 To ensure a stable torso position, apply and release a horizontal rearward load, not to exceed 10N, to the back pan molding at a height approximately at the centre of the torso weights. Care shall be exercised to ensure that no exterior downward or lateral loads are applied to the HPM.
- 3.5.4.3.19 Each foot shall be alternately lifted off the floor via the instep until no additional forward foot movement is available.
- 3.5.4.3.20 The 45 degree plane of the toe board shall be moved toward the feet such that the tip of the toe lies between the 230mm and 270mm lines taking care not to disturb the position of the HPM. To facilitate easier setting of BioRID, the toe board shall be moved such that the toes of the HPM feet are positioned nearer to the 230mm line.
- 3.5.4.3.21 When each foot is in its final position, the heel shall be in contact with the floor, and the sole of the foot shall be in contact with the 45 degree plane of the toe pan between the 230mm and 270mm lines.
- 3.5.4.3.22 If the HPM is not level after the feet have been repositioned, a sufficient load shall be applied to the top of the seat pan to level it on the vehicle seat. This may be verified using the bubble gauge fitted to the manikin or alternatively by verifying with CMM that the H-point positions on both sides of the machine are within ± 2.5 mm of each other.
- 3.5.4.4 Installation of the HRMD
- 3.5.4.4.1 The backset and height probes shall be installed and pushed flush against the HRMD.
- 3.5.4.4.2 The HRMD levelling knob shall be confirmed as finger tight and the plungers which engage at the HPM to HRMD interface shall be fully loosened.
- 3.5.4.4.3 The HRMD shall then be lowered into position on the HPM torso weight hangers and on the top edge of the channel between the hangers. During the fitment, ensure that the HRMD fits easily into place without inducing forces which might disturb the manikin position. Make note of any longitudinal movement of the manikin, and ensure that this results in consistent H-point position in the subsequent repeat drops conducted in section 3.5.5.5.
- 3.5.4.4.4 The HRMD shall be levelled by loosening the levelling knob at the rear of the device and repositioning the head using the HRMD bubble level;

the levelling knob shall then be retightened by hand.

3.5.4.4.5 Measure the torso angle on the calibrated block attached to the weight hanger bar.

3.5.4.4.6 If the measured angle is not $25^{\circ} \pm 1^{\circ}$, the HRMD and chest and buttocks weights shall be removed, the seat back readjusted, and the steps to position the HPM shall be repeated, beginning with tilting the back pan forward and pushing the HPM rearward as in 3.5.4.3.10.

3.5.4.4.7 If more than 3 installations of the HPM and HRMD are required to ascertain a seatback angle that supports a torso angle of $25^{\circ} \pm 1^{\circ}$, then the seat shall be allowed to recover for 15 minutes with nothing in it between each third and fourth installation. It is recommended to aim to set the SAE manikin as close as possible to the nominal target value for torso angle.

3.5.4.4.8 Some indexed seatback adjustments may have more than 2° between adjustments with none giving a torso angle between $25^{\circ} \pm 1^{\circ}$. In such cases, adjust the seatback to the most reclined position that supports a torso angle less than 24° .

3.5.4.4.9 The torso angle shall be recorded when it falls within the allowed range.

3.5.4.5 Record the location of the HPM H-point Markers

3.5.4.5.1 Record the H-point positions on both sides of the HPM using a CMM or other means to record the location of both H-points relative to the seat or sled.

3.5.4.5.2 The H-point position on both sides of the machine shall be within $\pm 2.5\text{mm}$ of each other in X and Z. If this is not the case, the installation procedure from 3.5.4.3.6 shall be repeated.

3.5.5 Head Restraint Positions

3.5.5.1 Head Restraint Measurement Position Definitions

3.5.5.1.1 Down is defined as the lowest achievable position of an adjustable head restraint regardless of other adjustments (e.g. tilt) and without using tools. The lowest position shall be assessed from the point of view of a seated occupant, and without using a third hand.

3.5.5.1.2 Up is defined as the highest adjusted détente position of an adjustable head restraint (taking into account locking détente positions, as defined in section 3.5.1.1.6, only).

3.5.5.1.3 Back is defined as the most rearward adjusted position of an adjustable head restraint, or if this is difficult to ascertain, “back” shall be taken as the position which results in the greatest “HRMD backset” when set at the test height.

3.5.5.1.4 Forward is defined as the most forward locking adjusted position of an adjustable head restraint, or if this is difficult to ascertain, “forward” shall be taken as the position which results in the least “HRMD backset” when set at the test height.

3.5.5.2 Head Restraint Test Positions

The same head restraint position shall be used for all three tests. If any variability exists in the locking mechanism, such as different levels of friction that affect that head restraint position then the TNCAP executive agency shall be informed immediately. The decision of the position to be used in the tests shall be made by the Secretariat. Where there is damage to a seat which affects the test position, details shall be noted by the technical service and provided in the test report, that seat shall not be used for test.

3.5.5.2.1 Head restraint test positions

The test position for the head restraint depends on whether it is fixed or adjustable and, if adjustable, whether the adjustments lock. Automatically adjusting head restraints are tested as if they are fixed restraints and the seat adjustments are set according to section 3.5.3.6.1.

3.5.5.2.2 Non-locking adjustable head restraint

The head restraint is first adjusted to its lowest vertical adjustment position as defined in section 3.5.5.1.1. If a non-locking tilt adjustment is available, this shall then be set to the most rearward horizontal adjustment position possible once the head restraint has been set to its lowest position.

3.5.5.2.3 Locking adjustable head restraints, midrange positions

The head restraint is adjusted to midrange of its vertical and/or horizontal adjustment positions. Only locking adjustments are set to the midrange positions. For example, a restraint with locking height adjustment and non-locking horizontal adjustment would be set to its midrange vertical position and most rearward horizontal position. The head restraint shall first be set for the midrange vertical position. Midrange tilt position shall then be set where this adjustment has locking notches.

3.5.5.2.3.1 Setting of Mid Range Height

3.5.5.2.3.1.1 Lowest Position

Some head restraints can be lowered below the lowest locking position and in these cases the bottom of the restraint may contact the top of the seatback. The lowest vertical adjustment position is defined in section 3.5.5.1.1.

3.5.5.2.3.1.2 Highest Position

The highest position is considered to be the highest locking position. If a restraint has a non-locking position above the highest locking position,

then the highest locking position is still considered as the highest position, see Figure 7.

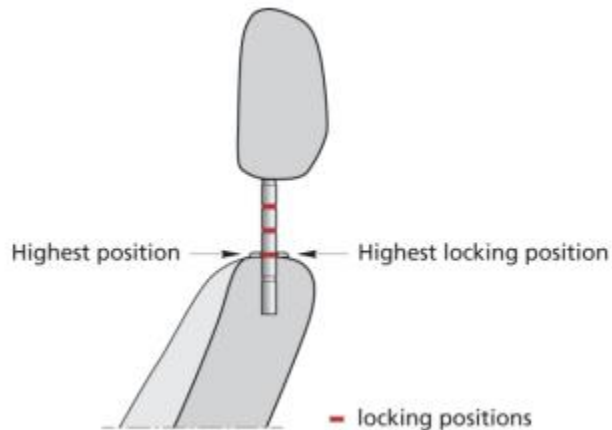

Figure 7 Examples of adjustment positions for head restraints with non-locking positions above/and or below the locking positions

3.5.5.2.3.1.3 When measuring the head restraint travel for the midrange positions, the seat must be adjusted according to section 3.5.3.6, the seatback must be adjusted according to section 3.5.4 and the HPM manikin shall be installed in the seat according to section 3.5.4.

3.5.5.2.3.1.4 Mark a repeatable reference point on the top of the head restraint. This point is typically the highest point on the centreline of the head restraint. Using a coordinate measurement device, this point shall first be measured in the lowest position as defined by in section 3.5.5.1.1, and then in the highest locking position without altering tilt or any other seat settings.

3.5.5.2.3.1.5 Midrange height position is determined by calculating the geometric mid point between the lowest position, and highest locking vertical adjustments, considering only the vertical component of measurement, see Figure 8. The test position will then be selected based on the following conditions:

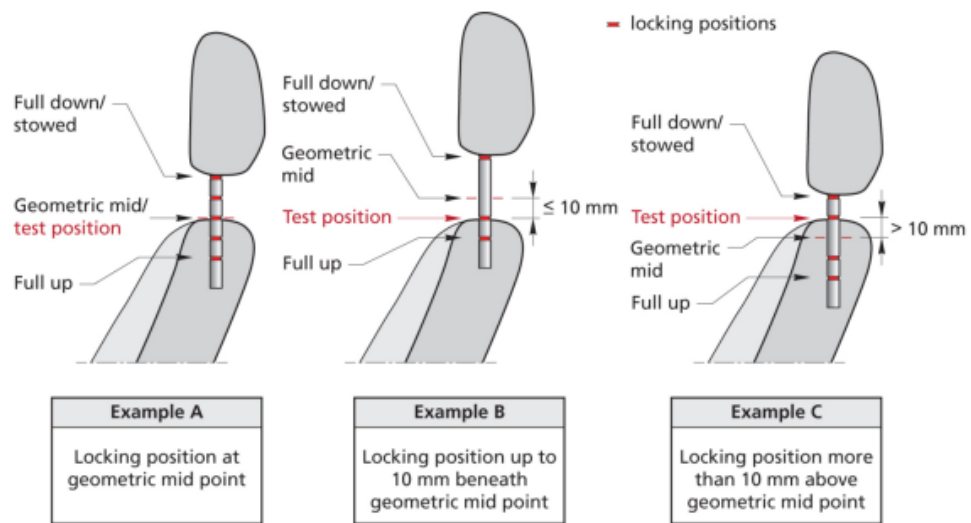

Figure 8 Examples of test position for head restraints with various locking configuration

3.5.5.2.3.1.5.1 Place the head restraint at the geometric mid point if a locking position exists there, see Figure 8, Example A.

3.5.5.2.3.1.5.2 If there is no locking position at the geometric mid point, raise the head restraint by up to 10mm. If a locking position exists within this 10mm of travel, that position will be the test position, see Figure 8, Example B.

3.5.5.2.3.1.5.3 If there is no locking position within 10mm above the geometric mid point, lower the head restraint to the next lowest locking position, see Figure 8, Example C.

3.5.5.2.3.1.5.4 If there is no locking position before the lowest or stowed position is reached, then the head restraint shall be positioned fully down.

3.5.5.2.3.1.5.5 Once the vertical test position has been determined, ensure the head restraint is returned to rearmost tilt position.

3.5.5.2.3.2 Setting of Mid Range Tilt (Locking Tilt Settings Only)

3.5.5.2.3.2.1 Following the setting of midrange height, the procedure shall be repeated for locking horizontal adjustments. For non-locking tilt adjustments, the head restraint shall be tilted fully rearward.

3.5.5.2.3.2.2 Mid tilt position may be influenced by the presence of the HRMD head, consequently the setting of mid range tilt shall be undertaken following successful installation of the H-point machine and HRMD and shall be completed while the equipment is still installed in the seat.

3.5.5.2.3.2.3 For HRMDs equipped with probes having 5mm increments only, a more accurate measurement technique is required to establish the mid position to within 1mm. Using a steel rule, measure the probe extension from the front of the headform at forward and rearward tilt settings. From this data a midpoint target may be derived.

3.5.5.2.3.2.4 Most Rearward Tilt shall be made using HRMD probe backset. The most rearward tilt position shall be that which results in greatest backset measurement. In the situation where the head restraint cannot be placed at most rearward tilt. For example due to a return spring, the most “most rearward tilt” shall be the most rearward position in which the tilt can be locked.

3.5.5.2.3.2.5 Most Forward Tilt shall be determined by finding the most forward locking tilt position. Non-locking positions located further forward than the most forward lock are disregarded. During determination of “most forward tilt” position, the head restraint may come into contact with the HRMD. If contact is achieved, the head restraint shall not be tilted further forward, and shall not be moved such that the HRMD position is affected. If a lock exists at the tilt position where the head restraint contacts the HRMD, this shall be considered the “most forward tilt” position. If no locking position exists in this location, the head restraint shall be tilted rearwards until a locking position is reached. This position shall then be considered “most forward tilt”.

3.5.5.2.3.2.6 Midrange Tilt Position is determined by calculating the geometric mid point between the most rearward tilt and most forward locking horizontal adjustments, considering only the HRMD probe backsets measured. Midrange tilt setting shall be undertaken using the same rationale as used in 3.5.5.2.3.1. A locking position shall be sought within a window 10mm forwards from the geometric mid point. If a lock is found within this window, that position shall be considered the test position. In the absence of a lock within this range the head restraint shall be moved rearwards until the next locking position is reached. If no locking positions are reached before the fully rearward tilt position, then fully rearward tilt shall be the test position.

3.5.5.3 Measure and Record the Head Restraint Geometry

- 3.5.5.3.1 Before measuring the head restraint geometry, ensure that:
- (1) The seat is set according to section 3.5.3.6.
 - (2) The H-point machine and HRMD are correctly installed in the seat according to section 3.5.4.
 - (3) The head restraint is set in the correct test position according to section 3.5.5.2.
- 3.5.5.3.2 When measuring backset and height, a light force (e.g. 1N) shall be applied, if needed, to ensure that any trim covering material is in contact with the underlying foams, or that the separation of trim material has not provided artificially favorable measurements.
- 3.5.5.3.3 Measure the HRMD backset to the nearest millimeter, with the backset probe in first contact with the head restraint. For the geometric assessment, the backset must be measured according to the HRMD backset probe scale, taking note of the method described in section 3.5.5.2.3.2.3 for probes with 5mm increments only. See Figure 9.
- 3.5.5.3.4 The height from the top of the head restraint to the height probe shall also be measured.
- 3.5.5.3.5 If the head restraint is too low to be contacted by the backset probe, record as ‘no contact’.
- 3.5.5.3.6 All measurements noted during 3.5.5.3.3 and 3.5.5.3.4 shall be used for the TNCAP geometry points calculation, as defined in the TNCAP assessment protocol.

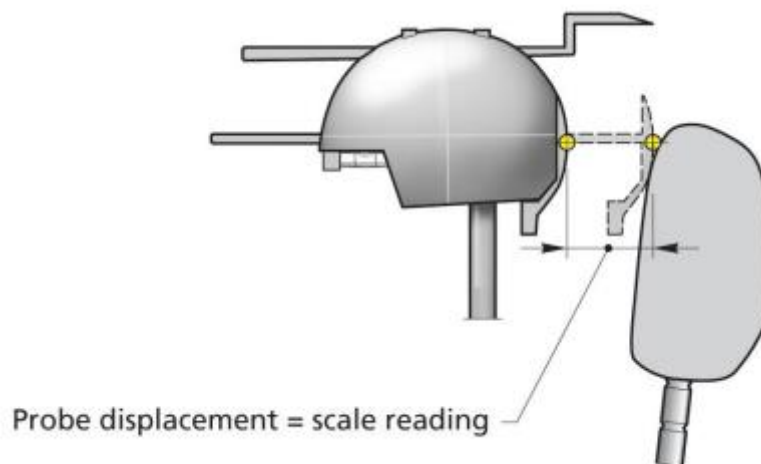

Figure 9 Backset probe for static geometry measurement

3.5.5.4 Measure and Record Reference Geometry for BioRID setup

The HRMD probe measurements used for the geometric assessment will be different than the geometry recorded for use during the BioRID setup. This is due to the curvature of the HRMD probes and is illustrated in Figure 10. Since the

BioRID is set up based on reference geometry recorded using the HRMD, there is a need to measure an equivalent feature on both devices. The rear most point on the HRMD skull (i.e. the screw on the backset probe) is equivalent to the rearmost point on the centreline of the dummy's skullcap. This point can be found using a measuring tape that contours to the shape of the skullcap: the point is 95mm from the top of the skullcap along the mid sagittal plane of the skull.

3.5.5.4.1 Mark an identifiable point on the head restraint along its vertical centreline. A suggested point is defined by first contact point between backset probe and head restraint.

3.5.5.4.2 Ensure that the backset probe is installed and pushed flush against the HRMD, i.e. stowed/retracted.

3.5.5.4.3 Locate the screw on the centre of the rear surface of the HRMD backset probe.

3.5.5.4.4 Measure and record the BioRID reference backset using CMM (as defined in section 3.5.1.3.3). This is the horizontal distance between the rearmost point on the HRMD skull (i.e. the screw on the retracted backset probe) and the identifiable point on the head restraint +15mm, see Figure 10.

3.5.5.4.5 Ensure that the head restraint has been marked such that it can reliably be returned to the test position. Move the head restraint to the lowest position as defined in section 3.5.5.1.1. Whilst maintaining that lowest position, move the head restraint to the most rearward tilt possible as defined by section 3.5.5.1.3 and 3.5.5.2.3.2.4. Measure the HRMD backset and height to the nearest millimeter using the probes.

3.5.5.4.6 All measurements noted during 3.5.5.4.5 shall be used for the TNCAP ease of adjustment assessment, as defined in the TNCAP assessment protocol.

3.5.5.4.7 Using the marks made in section 3.5.5.4.5, return the head restraint to the test position.

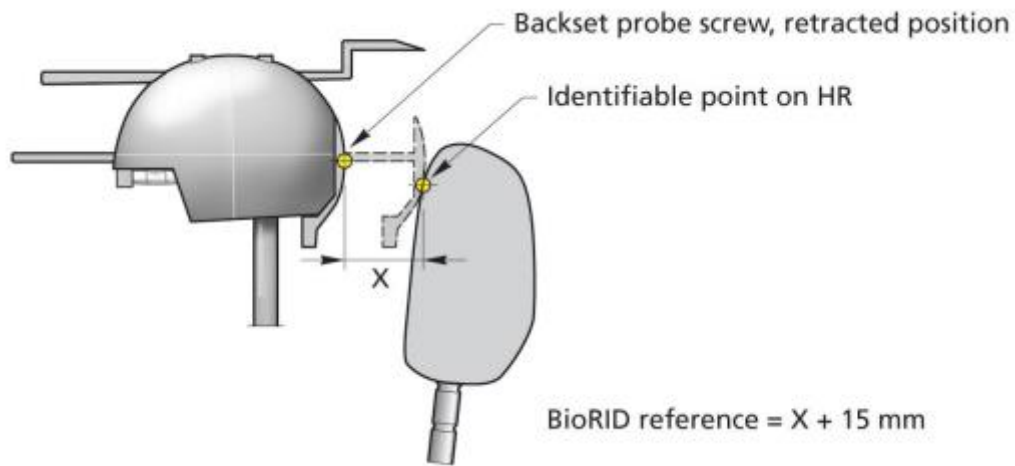

Figure 10 Measuring BioRID reference backset

3.5.5.5 Repeat Measurements

3.5.5.5.1 Remove the manikin and HRMD and repeat sections 3.5.4.3 to 3.5.5.4.6 two further times and record ALL measurements taken for each installation in both the test position (section 3.5.5.3.3) and the down and back position (section 3.5.5.4.5). For the repeat installations, the seat back angle shall not be adjusted. However, where a change in seat back angle is required to obtain a torso angle of $25^{\circ} \pm 1^{\circ}$, the installation procedure shall be repeated until three consecutive installations have been performed which require no seat back angle adjustment.

3.5.5.5.2 For each individual seat, ensure that the H-point X, H-point Z and reference backset measurements are within $\pm 5\text{mm}$ between the three sets of measurements. Outlying measurements shall be investigated and repeated to achieve consistent static measurement results as necessary.

3.5.5.5.3 Once each individual seat has been measured three times, calculate the average H-point position recorded in section 3.5.4.5 and average reference backset recorded in section 3.5.5.4. These shall be the BioRID setup targets from the three measurements taken on each individual seat.

3.5.5.6 Install BioRID

3.5.5.6.1 The seat shall have already been set to give a torso angle of $25^{\circ} \pm 1^{\circ}$ measured on the H-point machine fitted with HRMD as described in section 3.5.4. Allow the seat to recover for 15 minutes with nothing in it before installing the BioRID. Note, BioRID handling shall only be undertaken using dedicated lifting tools and associated locations on the dummy following the BioRID manufacturer recommendations. Typically, during the installation of BioRID the H-point will initially be installed further rearward in the seat than is required. Therefore the

- pelvis shall be moved forward to achieve the target set-up positioning.
- 3.5.5.6.2 Carefully place the seat belt across the dummy and lock as normal, ensure there is sufficient slack in the belt to allow positioning of BioRID.
- 3.5.5.6.3 Align BioRID's midsagittal plane with the centreline of the seat.
- 3.5.5.6.4 Adjust BioRID's midsagittal plane to be vertical; the instrumentation platform in the head shall be laterally level.
- 3.5.5.6.5 Adjust the pelvis angle to 26.5° from horizontal ($\pm 2.5^\circ$).
- 3.5.5.6.6 Position the H-Point 20mm forward (± 10 mm) and at the same Z-height (± 10 mm) as the location recorded in section 3.5.5.5.3, while keeping the pelvis angle at 26.5° ($\pm 2.5^\circ$). It is recommended to aim to set the ATD as close as possible to the nominal target values, and that the tolerance window shall only be used if there is an issue achieving the required H-Point target or backset value. The BioRID setup tolerances are summarized in Table 1.
- 3.5.5.6.7 Adjust the spacing of the legs so that the centreline of the knees and ankles is 200mm (± 10 mm) apart and ensure that the knees are level using an inclinometer or bubble gauge.
- 3.5.5.6.8 Adjust the dummy's feet so that the heel of BioRID's shoe is resting on the heel surface. The tip of the shoe shall rest on the toe pan between 230mm and 270mm from the intersection of the heel surface and toe board, as measured along the surface of the toe board. Figure 2 shows proper positioning of the feet. Note, the heel point from a vehicle is not replicated, only heel plane height is set according to vehicle geometry.
- 3.5.5.6.9 Position the BioRID's arms so that the upper arms are as close to the torso sides as possible. The rear of the upper arms shall contact the seatback, and the elbows shall be bent so that the small fingers of both hands are in contact with the top of the vehicle seat cushion with the palms facing the dummy's thighs.
- 3.5.5.6.10 Level the instrumentation plane of the head (front/rear and left/right directions) to within $\pm 1^\circ$. Electronic tilt sensors shall be used to perform this check.
- 3.5.5.6.11 The BioRID backset (as defined in section 3.5.1.3.4) is the horizontal distance between the rearmost point on the head, and the same identifiable location on the head restraint that was found when measuring the HRMD in section 3.5.5.4.1.
- 3.5.5.6.11.1 Mark the farthest rearward point on the centreline of the dummy's skullcap. Note, as defined in 3.5.5.4, this point is 95mm from the top of the skullcap along the midsagittal plane of the skull

measured using a tape that contours to the shape of the skullcap.

3.5.5.6.11.2 Measure the BioRID backset, using the point identified on the skullcap in 3.5.5.6.11.1 and the same identifiable location on the head restraint that was found when measuring the HRMD in section 3.5.5.4.1. See Figure 11.

3.5.5.6.12 If the BioRID backset is different from the BioRID reference backset obtained in section 3.5.5.4.4 ($\pm 5\text{mm}$), then do the following:

3.5.5.6.12.1 Tip the head for/aft no more than $\pm 1^\circ$ from level in order to meet the backset requirement.

3.5.5.6.12.2 If the BioRID backset cannot be brought closer to the BioRID reference backset $\pm 5\text{mm}$ by step 3.5.5.6.12.1, adjust the pelvis angle and H-point position within their respective tolerance bands. In this case begin at section 3.5.5.6.5 and adjust the BioRID position accordingly.

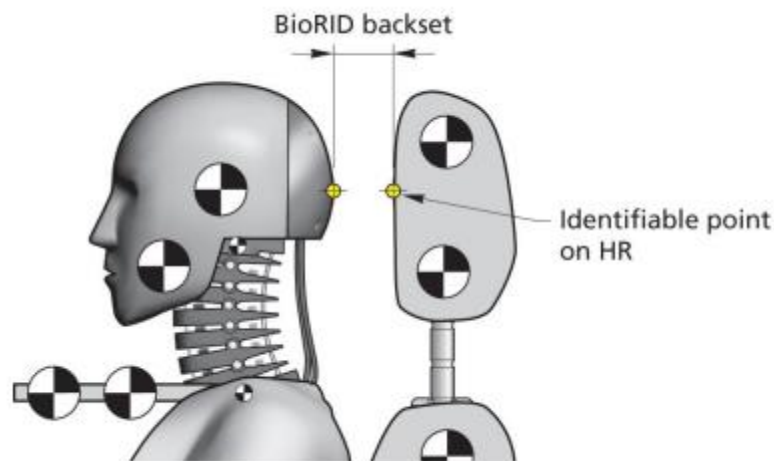

Figure 11 Measuring BioRID backset

3.5.5.6.13 Remove the slack from the lap section of the webbing until it is resting gently around the pelvis of the dummy. Only minimal force shall be applied to the webbing when removing the slack. The route of the lap belt shall be as natural as possible and must be above the pelvic angle gauge.

3.5.5.6.14 Place one finger behind the diagonal section of the webbing at the height of the dummy sternum. Pull the webbing away from the chest horizontally forward and allow it to retract in the direction of the D-loop using only the force provided by the retractor mechanism. Repeat this step three times, only.

3.5.5.6.15 Once the belt is positioned the location of the belt shall be marked across the dummy chest to ensure that no further adjustments are made.

Mark also the belt at the level of the D-loop to be sure that the initial tension is maintained during test preparation.

Table 1 BioRID setup summary

Location	Target Measure	Tolerance
H-point (X-axis)	+ 20mm forward*	±10mm
H-point (Z-axis)	0mm*	±10mm
Pelvis angle	26.5°	±2.5°
Head plane angle	0°(level)	±1°
Backset	15mm forward*	±5mm

Note: *Reference measurements taken using H-Point machine fitted with HRM

3.5.6 BioRID ATD Requirements

The tests shall be conducted with a BioRID IIg dummy built with ‘Mould 2’ jacket and fitted with electronic tilt sensors capable of measuring X and Y tilt for head and pelvis. The instrumentation umbilical shall exit at the front/side of the pelvis such that it is ensured there will be no seatbelt interaction. The dummy shall comply with both spine stature and dynamic response specifications before the test.

3.5.6.1 Spine Curvature Check

With the pelvis adapter plate placed on a level surface with the Occipital Condyle (OC) angle at 29.5° (±0.5°), the T2 angle at 37° (±0.5°), and the neck plate laterally level (±0.5°), the distance in (X) between the H-Point and the OC pin shall be 156mm (±5mm) and the distance in (Z) between the H-Point and the OC pin shall be 609mm (±5mm). See Figure 12. The curvature check shall be performed after every 15 tests and all measurements shall be recorded and fully documented.

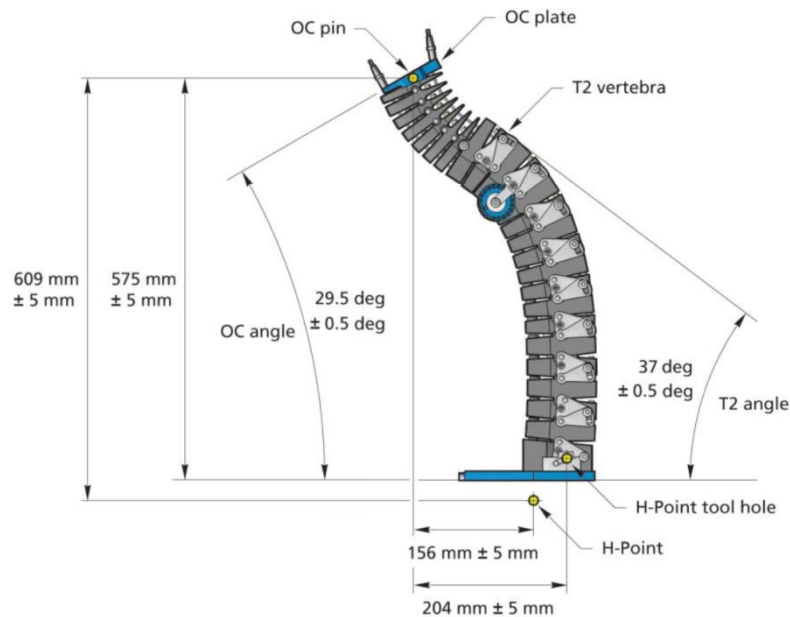

Figure 12 Spine curvature check

3.5.6.2 Certification

The dynamic response of BioRID is checked by attaching the spine, torso and head to a mini-sled that is impacted through foam by a 33.4kg probe and a velocity of 4.76m/s \pm 0.1m/s. The specified response of the dummy and detailed test specifications are described in Test Procedure: Calibration of BioRID available from Denton ATD, Inc. Generally, if the dummy's spine curvature changes so that it does not meet the dimensional specifications described in section 3.5.6.1, then likely it will no longer meet the dynamic response specifications. It is recommended that the BioRID be re-certified after every 15 tests and all certification documents provided in the technical service test report.

3.5.6.3 Adjustment of the Dummy Extremities

3.5.6.3.1 The stiffness of both arms and legs shall be checked and adjusted, where necessary, prior to every sled test. The adjustment procedure is as follows:

3.5.6.3.2 Arms

3.5.6.3.2.1 Extend the complete arm laterally outward to a horizontal position. Twist the arm so the elbow cannot rotate downward. Tighten the shoulder yoke clevis bolt so the arm is suspended at 1g, see Figure 13.

3.5.6.3.2.2 Rotate the complete arm assembly so it points forward and is horizontal. Twist the arm so the elbow cannot rotate downward. Adjust the shoulder yoke rotation hexagonal nut so the arm is suspended at 1g.

3.5.6.3.2.3 Bend the elbow by 90° so the hand moves toward the chest. Adjust the elbow rotation bolt through access in the upper arm to hold the lower arm horizontally suspended at 1g.

3.5.6.3.2.4 Reposition the arm so it points forward and is horizontal. Twist the lower arm at the elbow, so the lower arm can pivot downward to vertical. Adjust the elbow pivot bolt through access holes in the lower arm flesh at the elbow to hold the lower arm suspended at 1g, see Figure 13.

3.5.6.3.2.5 Extend the arm and twist the palm so it faces down. Adjust the wrist pivot bolt at the base of the hand so it is suspended at 1g.

3.5.6.3.2.6 Adjust the wrist rotation bolt through access in the wrist flesh to hold it suspended at 1g.

3.5.6.3.2.7 Repeat procedure for other hand and arm.

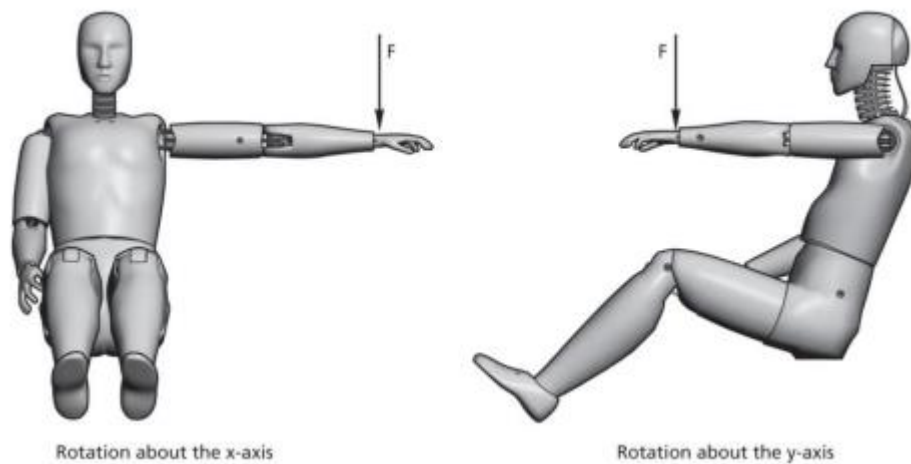

Figure 13 Dummy extremity settings

3.5.6.3.3 Legs

3.5.6.3.3.1 Remove the jacket from the dummy.

3.5.6.3.3.2 With the lower leg at 90° to the upper leg, and the dummy in seated position, lift the upper leg assembly above horizontal. Adjust the femur back set screw so the upper leg is held suspended at 1g.

3.5.6.3.3.3 Rotate the lower leg assembly so it is horizontal. Adjust the knee clevis bolt so the lower leg is held suspended at 1g.

3.5.6.3.3.4 Adjust the ankle ball joint screw so the foot is held suspended at 1g. The ankle adjustment is not critical and is determined by individual feet.

3.5.6.3.3.5 Repeat the procedure on the other leg and foot.

3.5.6.4 Clothing

3.5.6.4.1 The dummy shall be dressed with two pairs of close-fitting, knee-length, spandex/lycra pants and two close-fitting, short-sleeved spandex shirts. The under layer of clothes shall be worn with the shiny/smooth side of the fabric facing out and the over-clothes with the shiny/smooth side against the underclothes (i.e. dull side facing out). The dummies feet shall be shod with size 11 (45 European or 279mm) Oxford-style, hard-soled, work shoes (e.g. MIL-S-13192P).

3.5.6.5 Instrumentation

3.5.6.5.1 The instrumentation required to perform the TNCAP evaluation is listed in Table 2. The T1 acceleration shall be the average of right and left side accelerometer measurements. All instrumentation shall be calibrated before the test program.

3.5.6.5.2 The channel amplitude class (CAC) for each transducer shall be chosen to according to Table 2. In order to retain sensitivity, CACs which are

orders of magnitude greater than the minimum amplitude shall not be used. A transducer shall be re-calibrated if it reaches its CAC during any test. All instrumentation shall be recalibrated after one year regardless of the number of tests for which it has been used. A list of instrumentation along with calibration dates shall be supplied as part of the test report.

Table 2 Required instrumentation

Position	Function	Measurement	CFC	CAC
Sled X	Pulse acceptance	Acceleration (g)	60	100
	Pulse acceptance	Velocity (m/s)	30	NA
	Rebound velocity	Displacement (m)	NA	NA
Head X	NIC	Acceleration (g)	60	100
		Acceleration (g)	1000	100
Head CoG X	Rebound velocity	Velocity (m/s)	30	NA
Neck T1 X (LH and RH)	NIC	Acceleration (g)	60	100
Neck Force X		Force (N)	1000	1400
Neck Force X	My OC and Nkm	Force (N)	600	1400
Neck Force Z		Force (N)	1000	4500
Neck Moment Y	My OC	Moment (Nm)	600	115
Head Restraint Contact Time (T-HRC)	T-HRCstart and T-HRCend	Time (ms)	NA	NA
Neck T1 X		Force (N)	1000	5000
Neck T1Z		Force (N)	1000	5000
Neck T1 Moment Y		Moment (Nm)	600	200
1 st Lumbar X		Acceleration (g)	60	200
1 st Lumbar Z		Acceleration (g)	60	100
Seat Belt Force (lap section)		Force (kN)	60	16

3.5.6.6 Data Acquisition and Processing

3.5.6.6.1 The measurement data shall be recorded according to ISO 6487 or SAE J211/1 at a minimum sample frequency of 10kHz Table 2 specifies the channel frequency classes for each necessary measurement.

3.5.6.6.2 Measurement data shall be considered for evaluation until the point in time at which the head rebounds from the head restraint or at 300ms after T-zero, whichever occurs first.

3.5.6.6.3 Prior to test all data channels shall be offset to zero, where zero (acceleration/force/moments) is defined by the average quiescent channel value over 100 samples at 10kHz (or equivalent) before time

offset. This shall be recorded a significant duration prior to T0 such that the sled acceleration/deceleration phase is avoided.

3.5.7 Test Sled Requirements

3.5.7.1 Acceleration Sled

The dynamic test is intended to simulate a typical rear crash in which the rear-struck vehicle is initially stationary or moving forward very slowly. Consequently, an acceleration sled with the dummy seated facing the direction of motion is required for these tests. Some sled motion is allowed at the initiation of the test (T=0). To accommodate different sled types and different relationships between sled motion and the recording of test data, test time will be indexed as described in section 3.5.13. The sled shall not brake before 300ms from T=0. A deceleration sled is no longer accepted for official TNCAP testing due to its inherently larger variability.

3.5.7.2 Test Time Indexing

To normalize the time index among sled technical service protocols with different T-zero trigger levels, the time indexing procedure described in section 3.5.13 shall be used.

3.5.7.3 Technical service Environment

The temperature in the technical service shall be $22.5^{\circ} \pm 3^{\circ}\text{C}$ and a relative humidity of between 10% and 70%. The BioRID test dummy and seat being tested shall be soaked at this temperature at least 3 hours prior to the test.

3.5.7.4 Acceleration Pulse

The target sled accelerations and pulse specifications are given in section 3.5.13. Sled accelerations shall be measured by an appropriate accelerometer attached to the sled platform, recorded according to SAE Recommended Practice J211 – Instrumentation for Impact Testing – Part 1 – Electronic Instrumentation. Prior to establishing conformance with the acceleration pulse specification, any quiescent signal bias shall be removed from the acceleration measurement and the data shall be filtered in accordance with Table 2.

3.5.8 Test Sled Instrumentation

3.5.8.1 Record the X-acceleration of the sled in accordance with SAE recommended practice J211. The instrumentation shall be directly attached to the sled platform and not to any other part of the test device.

3.5.8.1.1 If necessary, remove any data channel DC bias. Typically, the value of the average measurement over 100 samples of the quiescent data channel signal is subtracted from every test measurement.

3.5.8.1.2 Filter the sled acceleration to channel frequency class in accordance with Table 2.

3.5.8.2 The time of dummy head to head restraint first contact shall be recorded with a foil contact switch.

3.5.9 Whiplash Assessment Criteria

3.5.9.1 The purpose of the whiplash test is to test the seat and head restraint assembly in order to assess the extent to which they reflect best practice in preventing soft tissue neck injuries. This is based on the following performance criteria:

- (1) Head Restraint Contact Time (T-HRC (start), T-HRC (end)).
- (2) T1 X-acceleration (T1).
- (3) Upper Neck Shear Force (Fx) and Upper Neck Tension (Fz).
- (4) Head Rebound Velocity.
- (5) NIC
- (6) Nkm
- (7) Seatback dynamic opening.

Below a more extensive description is given for the most important assessment criteria.

3.5.9.2 Head Restraint Contact Time T-HRC (start)T-HRC(end)

Head restraint contact time shall be ascertained using a contact switch method, comprised of a proprietary lightweight, self adhesive conductive foil placed over the surface of the head restraint, and the rear of the ATD skull cap.

Head Restraint Contact Time T-HRC(Start) is defined as the time (calculated from T=0) of first contact between the rear of the ATD head and the head restraint, where the subsequent continuous contact duration exceeds 40ms. For the purposes of assessment, T- HRC(Start) shall be rounded to the nearest millisecond.

Minor breaks in the contact time (up to 1ms) are permissible if it can be proven that these are due to poor electrical contacts, however these must be investigated with reference to the film to ascertain whether the breaks in contact are not due to biomechanical phenomena such as ATD ramping, head restraint or seatback collapse, or 'bounce' of the head during non-structural contact with the head restraint. For the subsequent criteria, the end of head restraint contact must also be found; T-HRC(end). This is defined as the time at which the head first loses contact with the head restraint, where the subsequent continuous loss of contact duration exceeds 40ms.

3.5.9.3 T1 X-Acceleration

BioRID is fitted with twin accelerometers on the first thoracic vertebra (T1), one on either side of the lower neck loadcell assembly. The data channels acquired from these accelerometers shall both be filtered to channel frequency class (CFC) 60 as defined by SAE J211. An average channel, T1(t), shall then be produced from the two filtered signals, as follows:

$$T1(t) = \frac{T1_{\text{left}}(t) + T1_{\text{right}}(t)}{2}$$

where :

$T1_{\text{left}}(t)$ = Acceleration channel measured by the left hand T1 accelerometer.

$T1_{\text{right}}(t)$ = Acceleration channel measured by the right hand T1 accelerometer.

The maximum, $T1_{\text{max}}$ shall be generated from this average T1 channel, considering only the portion of data from T-zero until T-HRC (end) as follows:

$$T1_{\text{max}} = \text{Max}_{T\text{-HRC}(\text{end})} [T1(t)]$$

3.5.9.4 Upper Neck Shear Force (Fx) and Upper Neck Tension (Fz)

The upper neck loadcell of the BioRID records both shear and tensile forces. If the instrumentation is configured in accordance with SAE J211, positive shear shall be indicative of a head-rearwards motion and positive tension shall be associated with pulling the head upwards, generating a tensile force in the neck. Firstly, both the Fx and Fz channels shall be filtered at CFC 1000. Peak values, Fx_{max} and Fz_{max} , shall then be determined for each of the forces, considering only the portion of data from T-zero until T-HRC_(end), as follows:

$$Fx_{\text{max}} = \text{Max}_{T\text{-HRC}(\text{end})} [Fx(t)]$$

$$Fz_{\text{max}} = \text{Max}_{T\text{-HRC}(\text{end})} [Fz(t)]$$

3.5.9.5 Head Rebound Velocity – Acceleration Sled Technique

The head rebound velocity (in the horizontal/X direction) shall be determined using target tracking. Ideally this shall be performed using footage acquired from on-board camera systems, however off-board systems can provide suitable views providing the camera positioning is correct and compensation is made for the movement of the sled. Various proprietary film analysis packages include functions to achieve this analysis consequently this method will not be covered in detail in this document. Refer to the TNCAP Film and Photo protocol for additional considerations regarding the use of high speed cameras.

3.5.9.5.1 Time for occurrence of peak rebound velocity

Theoretically, the peak rebound velocity shall occur due to the elastic energy release from the seat assembly, after the peak sled acceleration has occurred. In the case of an acceleration sled this shall also be prior to the sled braking, which at the earliest shall occur from 300ms. It shall be verified that there is sufficient time before the onset of sled braking for the particular sled being used, and that any peak rebound velocity analysis is not undertaken during the sled braking phase. The rebound velocity of the ATD is usually generated due to the release

of stored elastic energy within the seat structure, suspension and foam. The time of occurrence of peak rebound velocity shall be the maximum horizontal component of head rebound velocity calculated between T=0 and 300ms.

3.5.9.5.2 Target Placement

The ATD shall be equipped with a suitable target placed on the side of the head flesh, coincident with the head centre of gravity. Additionally, three sled targets will be required. Two fixed targets of known separation shall be placed on the sled in the same XZ plane, such that a fixed reference can be obtained that will not be obscured during the test (B1 and B2 targets). In the case of an onboard view, a small compensation may be required for camera movement or shake. This can be made using the two fixed targets of known spacing on the sled, and a third target from which a sled coordinate system may be created. All target points used for analysis shall be depth scaled to compensate for any differences in the Y-coordinates.

3.5.9.5.3 Determination of Rebound Velocity

Using a suitable “target tracking” film analysis technique, generate traces as follows:

- (1) Head center of Gravity target velocity (absolute technical service reference)
- (2) Sled velocity (absolute technical service reference)

Both traces shall be offset adjusted then filtered at CFC30. Head rebound velocity is then defined as the difference between the sled velocity and the head velocity. Rebound velocity can be calculated as:

$$V_{Rebound} = V_{Head\ C-of-G\ (abs)} - V_{Sled\ (abs)}$$

where:

$V_{Rebound}$ = C-of-G (abs) = Instantaneous X-velocity of head C-of-G, absolute.

$V_{Sled\ (abs)}$ = Instantaneous X-velocity of sled, absolute.

$V_{Sled\ (abs)}$ = Instantaneous X-velocity of sled, absolute.

Generate a third trace of head centre of gravity rebound velocity, relative to the sled. The maximum value and the time at which this occurs shall be noted. It shall be verified using the end of head restraint contact time, T-HRC_(end), that this maximum is during the rebound from the head restraint and is not generated within the sled braking phase. Shall higher peaks be generated in the sled braking phase, these shall be disregarded and the initial peak of rebound velocity which occurs at or very near to initial rebound from the head restraint shall be taken as the peak value.

3.5.9.6 NIC Calculation

The NIC is based on the relative horizontal acceleration and velocity of the occipital joint relative to T1. To calculate NIC, two data channels are needed, which are the head x-acceleration and average T1 x-acceleration.

Each channel shall first be converted from ‘g’ to meters per second squared (m/s²), and the head x-acceleration shall be filtered at CFC 60. The average T1 channel (previously calculated) is the result of combining two channels, both of which were filtered at CFC 60.

Reference shall be made to section 3.5.9.3 for details of how this average channel is produced.

The “relative x-acceleration” (γ_x^{rel}) between head and T1 shall be generated by subtracting the head x-acceleration (γ_x^{head}) from the T1 x acceleration (γ_x^{T1}).

This channel is calculated as follows:

$$\gamma_x^{rel} = \gamma_x^{T1} - \gamma_x^{head}$$

The relative x-velocity (V_x^{rel}) between head and T1 shall be calculated, by integrating the relative acceleration channel with respect to time, as follows:

$$V_x^{rel}(t) = \int_0^t \gamma_x^{rel}(\tau) d\tau$$

The NIC channel is then calculated as a combination of relative acceleration multiplied by 0.2, and added to the square of the relative velocity. The calculation is according to the following equation:

$$NIC(t) = 0.2 * \gamma_x^{rel}(t) + [V_x^{rel}(t)]^2$$

The maximum overall NIC value (NIC_{max}) shall be determined from the trace, considering only the data portion from T0 until T-HRC (end), as follows:

$$NIC_{max} = \text{Max}_{T-HRC(end)} [NIC(t)]$$

This maximum value shall be noted, along with the time at which it occurs.

3.5.9.7 Nkm Calculation

The following definition is provided following the commonly accepted convention that derives the “Anterior/ Posterior” directions from the torso motion relative to the head. Consequently, torso forward motion relative to the head would be referred to as ‘anterior’, and providing SAE J211 compliant instrumentation is used, would produce an associated positive upper neck shear force, F_x^{upper} . (“Head rearward relative to the torso”) Conversely, the movement of the torso rearward

relative to the head is referred to as ‘posterior’ and produces the opposite sign of shear force.

The Nkm criterion is based on a combination of moment and shear forces, using critical intercept values for the load and moment. The shear force intercept value is identical for anterior or posterior values, being 845N in both directions of loading. However, the critical intercept value for the bending moment depends on the direction of loading, having a value of 47.5Nm in extension (head rotation rearwards), but a value of 88.1Nm in flexion (head rotation forwards).

Two channels will be required to perform the Nkm calculation, upper neck shear force F_x^{upper} , in Newtons (N) and moment, M_y^{upper} in Newton-metres (Nm). Typically the shear force will be acquired in kilo-Newtons (kN), and so in those cases, a conversion from kilo-Newtons (kN) to Newtons (N) will be required. Once it has been confirmed that both shear force and moment are in the correct units, filter

M_y^{upper} at CFC 600, according to SAE J211. To allow combination of the M_y^{upper} and F_x^{upper} channels, another F_x^{upper} channel shall be produced, filtered at CFC 600. Due to the construction of the BioRID, a correction must then be made to convert the actual moment measured by the upper neck loadcell into the moment about the Occipital Condyle (OC).

The corrected moment, M_y^{OC} is equal to the upper neck shear force F_x^{upper} multiplied by a constant, D, then subtracted from the measured moment, M_y^{upper} . Calculate the Moment about the OC according to the following equation:

$$M_y^{OC}(t) = M_y^{upper}(t) - D \times F_x^{upper}(t)$$

where $D = 0.01778\text{m}$

The four components of Nkm are then calculated using the upper neck shear force F_x^{upper} and the corrected moment about the OC, M_y^{OC} .

Each channel first needs to be separated into its positive- or negative-going components by generating four new channels as follows:

- (1) Generate two new channels, F_{xa} and F_{xp} , based on F_x^{upper} force channel.
 - (2) Generate two new channels, M_{yf} and M_{ye} based on the M_y^{OC} moment channel.
- Each of the new channels shall contain only selected positive or negative-going portions of the respective F_x or M_y channels, with all unwanted data points being replaced by null or zero value, as defined by:

- (1) F_{xa} channel contains only the positive portion of the F_x^{upper} force channel as follows:
If $F_x^{upper}(t) > 0$, then $F_{xa}(t) = F_x^{upper}(t)$, else $F_{xa}(t) = 0$
- (2) $F_{xp}^{channel}$ contains only the negative portion of the F_x^{upper} force channel as follows:

If $F_{xupper}(t) < 0$, then $F_{xp}(t) = F_x^{upper}(t)$, else $F_{xp}(t) = 0$

(3) M_{yf} channel contains only the positive portion of the M_y^{OC} moment channel as follows:

If $M_y^{OC}(t) > 0$, then $M_{yf}(t) = M_y^{OC}(t)$, else $M_{yf}(t) = 0$

(4) M_{ye} channel contains only the negative portion of the M_y^{OC} moment channel as follows:

If $M_y^{OC}(t) < 0$, then $M_{ye}(t) = M_y^{OC}(t)$, else $M_{ye}(t) = 0$

The four components of Nkm are then defined as:

(1) "Neck Extension Posterior" (N_{ep}) or the combined negative-going portion of the shear force channel (F_{xp}) and negative-going portions of the moment channel (M_{ye}), as defined by:

$$N_{ep}(t) = \frac{F_{xp}(t)}{F_{x-int}} + \frac{M_{ye}(t)}{M_{ye-int}}$$

where $F_{x-int} = -845N$, $M_{ye-int} = -47.5Nm$

(2) "Neck Extension Anterior" (N_{ea}) or the combined positive-going portion of the shear force channel (F_{xa}) and negative-going portions of the moment channel (M_{ye}), as defined by:

$$N_{ea}(t) = \frac{F_{xa}(t)}{F_{x-int}} + \frac{M_{ye}(t)}{M_{ye-int}}$$

Where: $F_{x-int} = 845N$, $M_{ye-int} = -47.5Nm$

(3) "Neck Flexion Posterior" (N_{fp}) or the combined negative-going portions of the shear force channel (F_{xp}) and positive-going portions of the moment channel (M_{yf}), as defined by:

$$N_{fp}(t) = \frac{F_{xp}(t)}{F_{x-int}} + \frac{M_{yf}(t)}{M_{yf-int}}$$

Where: $F_{x-int} = 845N$, $M_{yf-int} = 88.1Nm$

(4) "Neck Flexion Anterior" (N_{fa}) or the combined positive-going portions of the shear force channel (F_{xa}) and positive-going portions of the moment channel (M_{yf}), as defined by:

$$N_{fa}(t) = \frac{F_{xa}(t)}{F_{x-int}} + \frac{M_{yf}(t)}{M_{yf-int}}$$

Where: $F_{x-int} = 845N$, $M_{yf-int} = 88.1Nm$

Each of the four components shall be calculated as a new data channel, using only the positive- or negative-going portions of the F_x and M_y channels as appropriate, and the relevant critical intercept values. Maxima for each of the four components shall be calculated, considering only the portion of data from T-zero until T-HRC_(end), as follows:

$$N_{ep(max)} = \text{Max}_{T-HRC(end)} [N_{ep}(t)]$$

$$N_{ea(max)} = \text{Max}_{T-HRC(end)} [N_{ea}(t)]$$

$$N_{fp(max)} = \text{Max}_{T-HRC(end)} [N_{fp}(t)]$$

$$N_{fa(max)} = \text{Max}_{T-HRC(end)} [N_{fa}(t)]$$

The Nkm value is taken as the maximum value reached by any one of the four components (N_{ea} , N_{ep} , N_{fa} , N_{fp}).

It shall be noted which component of the four reached the maximum value and the time at which this occurred.

3.5.9.8 Seatback dynamic deflection

Using a suitable target tracking film analysis technique, measure the seatback dynamic opening from the targets defined in the TNCAP Film and Photo protocol as follows:

- (1) Define a line between the upper and lower seatback targets, ST2 and ST3.
- (2) Define a second line between the forward and rearward sled base targets, B1 and B2.
- (3) Calculate the angle between these two lines at the T-zero position. The instantaneous seatback deflection is defined as the instantaneous difference in angle between the T-zero position and the deflected position. Track the change in instantaneous angle between these two lines, throughout the dynamic test. The Seatback Dynamic Opening is defined as the maximum change in angle achieved at any time during the test between the T zero position and T-HRC_(end). Note this maximum angle, and the time at which it occurred.

For seats with two-point adjusting back, the same seatback deflection criterion will apply using targets ST2 and ST3, however it is recommended to use the two optional targets ST2' and ST3' (defined in the TNCAP Film and Photo protocol) such that any contribution from deflection in the two point mechanism can be understood.

3.5.10 Manufacturer's Specified Settings

Prior to preparation of the sled and seats, the following information shall be provided

by the manufacturer to allow for the test preparation.

Adjustment	
Whiplash preparation	
Seat mounting information, drawings etc.	<p>Required information:</p> <ul style="list-style-type: none"> ● Floor mounting pattern ● Seat rail angles ● Seat rail travel (especially if different on both sides) ● Fixation/support information <p>The manufacturer shall supply suitable seat mountings to the technical service.</p>
Heel plane height	
Seat belt anchorage positions	Where required
Anticipated seat settings Seat back angle (e.g. 3 notches from forward)	<ul style="list-style-type: none"> ● Seat back angle reference point wrt. seat reference point or HR tube angle.
Triggering information for active systems (pre-tensioners, active HR, etc.)	<ul style="list-style-type: none"> ● Triggering system details, all relevant information (magnetic, electronic, required current/voltage, pulse duration etc.)

3.5.11 RCAR GLORIA Jig & Calibration Procedure (HPM/HRMD Calibration)

3.5.11.1 Introduction

For the purposes of standardized seating positions for anthropomorphic test devices the SAE (Society of Automotive Engineers) designed the H-Point Machine (H-PM) that allowed a uniform definition of the human H-Point. Much of this work was completed in the late 1950's with the machine still in constant use today. The SAE J826 procedure was also defined to allow consistent and authoritative H-points and seating reference points to be defined.

Since the height probe was insufficient to measure both height and backset a head form was designed to fit the H-Point machine, known as the Head Restraint Measuring Device (HRMD). The HRMD probes allow the measurement of both head restraint height and backset and are used to rate whiplash protection in the RCAR (Research Council for Automobile) Head Restraint Measurement procedure.

Research studies from Thatcham and Partnership for Dummy Technology and Biomechanics (PDB) have both shown the location of the H-point on different H-PMs shows little variability. However the location of the weight hangers shows

some variability, and this location is not controlled by any calibration procedure. The weight hanger location variability can be transferred to the HRMD, and could affect backset measurements. This could consequently affect head restraint static geometry ratings, so a calibration procedure was developed with the aim of controlling H-PM & HRMD units.

3.5.11.2 Scope

This procedure is designed to allow the calibration of H-PM and HRMD units in isolation or together to restrict build tolerance variations of items currently poorly controlled and allow more repeatable and reproducible results.

3.5.11.3 Definitions

3.5.11.3.1 HPM/OSCAR

Machine defined to locate the H-point. H-PMs can be either the SAE J826 or 3D-H type of manikin, from the US or Europe respectively. It represents a 50th percentile adult male mass and basic morphology. It consists of a module GRP seat/ buttock pan with a metal spine to which are attached weights to represent the average human male. The unit has one central pivot around the pelvis a point which corresponds with that of the H-point. The unit has legs and articulated feet which are all adjustable to represent different percentiles. The unit has attached to the main pivot a height probe and inclinometer not used in the head restraint measurement process. Also known as OSCAR.

3.5.11.3.1.1 SAE J826 Seating Manikin

The US version of the HPM.

3.5.11.3.1.2 3D-H Seating Manikin

The European version of the HPM without the force plunger or the thigh bar and with an additional 1 kg mass.

3.5.11.3.2 HRMD

The Head Restraint Measuring Device consists of a cast magnesium or machined aluminum head representing the basic dimensions of an adult male. The head form is attached to an arm representing the neck with a joint at the T1 area to allow the head to be levelled in the X plane. The HRMD is attached to the H-PM via two machined forks that fit onto the weight hanger of the H-PM. The unit is located via a third tongue that slots into the H-PM spine box.

To facilitate measurement of head restraint geometry two probes are attached to the head form. The first fits into the centre of the head form and is profiled to that of the back of the skull. It is able to slide in and out of the head and has gradations to allow backset measurements to be taken. A similar height probe slides horizontally from the top of the head and allows the height of a head restraint to be measured. When fitting the H-PM to the HRMD it shall be noted

that the H-PM must first be modified to accept the unit. The height bar must be removed and its spacing on the spine spindle be replaced by two washers. Four of the original 8 hanger weights are replaced by two larger cylindrical weights. These allow the HRMD forks to locate onto the weight hanger.

3.5.11.4 Equipment Requirements

3.5.11.4.1 HPM/HRMD Calibration Jig

The H-PM/HRMD unit is to be calibrated together as one single unit. The H-PM/HRMD unit is held in a jig, known as GLORIA, which will facilitate calibration. The jig is equipped with feet at each corner to facilitate levelling. The jig holds the seat pan by three horizontal bars of 20mm thickness that support the seat pan allowing the thigh bar to be horizontal. The back pan is supported by 900mm vertical bar with its origin at the base of the seat pan in the area of the buttock. This vertical support has a horizontal bar at the level of the weight hanger bar and is level. A cord is attached to the back pan to prevent the H-PM falling forward. Near the top of the vertical support are scribed markings to indicate the target position of the HRMD height probe. This vertical support allows the calibration of the backset probe when extended.



Figure 14 The HPM/HRMD calibration jig (GLORIA)

3.5.11.5 Setup and Assembly of GLORIA Jig

3.5.11.5.1 The calibration shall be carried out in a room with temperature at $20^{\circ}(\pm 5^{\circ})$ and the HRMD, H-PM and GLORIA jig shall have been soaked in that same environments for 6 hours prior to commencing with step 3.5.11.3.2.

3.5.11.5.2 The GLORIA jig shall be set on a nominally level surface and levelled by adjustment of the threaded feet. The base plate shall be levelled using an inclinometer. Surfaces to be used as reference are the lower horizontal section of the side rails and the seat pan support rods. Then the front and side surfaces of the vertical support shall be checked to ensure the column is still vertical. All four measurements shall be undertaken to ensure the unit is level. Tolerance for this levelling operation is $\pm 0.1^\circ$.

3.5.11.5.3 Remove the H-Point locator rods from the jig left and right.

3.5.11.5.4 Remove the Vertical H-Point to weight hanger bar supports along with the weight hanger guide assembly by extracting the removable rods.

3.5.11.5.5 Loosen the 4 bushes on the seat pan front and rear horizontal support bars and slide them outboard.

3.5.11.6 Preparation of H-PM prior to Calibration

3.5.11.6.1 Ensure that the H-PM Headroom Probe has been removed and replacement spacers installed prior to this calibration in accordance with the HRMD set up procedure (see HRMD User Guide ICBC 1999). Ensure that the H-PM to be calibrated has had the top edge of the weight hanger assembly modified to accept the HRMD unit (Figure 15).



Figure 15 The modified weight hanger assembly

3.5.11.6.2 Remove the H-Point locator plugs from the seat pan left and right.

3.5.11.6.3 When re-assembling the H-PM manikin without the Head Room Probe care shall be taken to ensure that the H-Point pivot nuts are tightened to a torque of X-Y Nm. When set at this torque the manikin back pan can fall forward hence the use of the support strap.

3.5.11.7 Installation and Calibration of H-PM

3.5.11.7.1 Fold the H-PM forward to allow easier installation into the jig.

- 3.5.11.7.2 Install the H-PM into the jig ensuring that the rear of the seat pan is in contact and square to the rear upper horizontal bar.
- 3.5.11.7.3 Centre the seat pan on the horizontal support bars and slide the bushes inboard allowing them to contact the seat pan. Tighten the bushes' set screws.
- 3.5.11.7.4 Adjust the rear Concentric Adjustment Bar from both sides to visually align the H-point holes forward and aft on the H-PM seat pan with the corresponding holes on the side plates of the jig.
- 3.5.11.7.5 Adjust the lower Concentric Adjustment Bar from both sides to visually align the H-point holes up and down on the H-PM seat pan with the corresponding holes on the side plates of the jig.
- 3.5.11.7.6 Install the H-Point locator rods through the vertical support guides and then into the H-point guides of the jig base and then through to the H-point holes on the H-PM (Figure 16).



Figure 16 H-point locator bars installed through vertical support rods, jig side and HPM H-point location

- 3.5.11.7.7 Adjust the front Concentric Adjustment Bar from both sides to level the T-bar ($\pm 0.5^\circ$).
- 3.5.11.7.8 Check for horizontal play in the H-PM at the H-Point / torso pivot to check for excessive wear. Tighten or replace as necessary.
- 3.5.11.7.9 Raise the back pan until it rests upon the jig's vertical support bar and secure with the elastic strap to prevent the back from tipping forward (Figure 17).



Figure 17 HPM back pan held by support strap

- 3.5.11.7.10 Install the weight hanger alignment fixture over the weight hangers to check for alignment. The fixture shall be allowed to settle under its own weight, no force shall be applied to fit. If this fixture will not locate then it indicates that the weight hanger bars are out of alignment and will require modification and the procedure shall be terminated.
- 3.5.11.7.11 Remove the weight hanger alignment fixture and support strap. Tip the back pan forward and install the black cylindrical weight hanger bar guides at each out board end of the H-PM weight hanger bars between the bars and the jig arms. Replace the back pan and support strap.
- 3.5.11.7.12 Visually check alignment of the weight hanger bar guides with the holes in the jig arms.
- 3.5.11.7.13 If alignment is correct then proceed. If it is not possible due to interference between the H-PM back pan and vertical support then adjustment of the back pan to seat pan offset will be necessary which is outside the scope of this document. This procedure shall therefore be terminated here.
- 3.5.11.7.14 If the alignment is not possible due to the misalignment of the H-PM's weight hanger support rods then these shall be adjusted to achieve alignment.
- 3.5.11.7.15 Raise the weight hanger guide bars either side of the jig and insert the weight hanger locator pins through the guide bars, arms and into the black cylindrical weight hanger bar guides (Figure 18).



Figure 18 Weight hanger support pins inserted through weight hanger guide bars
3.5.11.8 Calibration of the H-PM Unit

3.5.11.8.1 Once installed in the jig check to ensure that the flat portion of the H-PM back pan is parallel to the vertical jig support and that the gap is no more than 4mm. It is allowed to touch (Figure19).

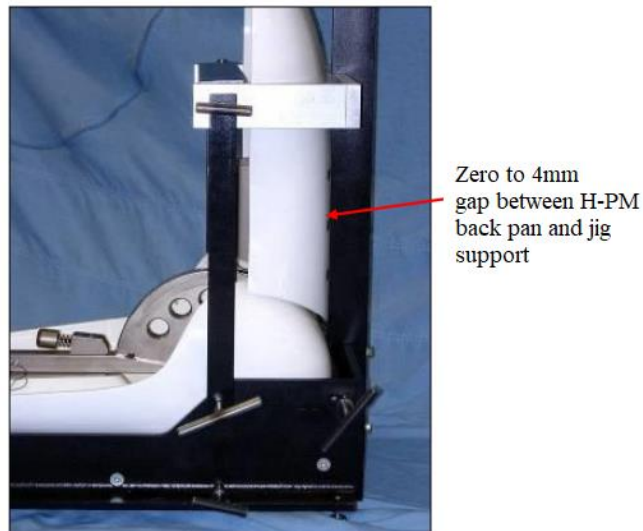

Figure 19 HPM installed into the jig without HRMD assembly. A check shall be made to ensure that the gap between the HPM back pan and jig vertical support is no more than 4mm

3.5.11.9 Installation of HRMD

- 3.5.11.9.1 Install the HRMD unit with the backset and height probes pre-installed onto the H-PM assembly as per HRMD User Manual ICBC 1999
- 3.5.11.9.2 Ensure that the plungers fitted to the centre locator fork on the HRMD are in good condition and that they are tight enough to allow the fork to contact the rear surface of the H-PM weight hanger support.
- 3.5.11.9.3 Level the HRMD head using the adjuster knob and the integral spirit level. Confirm that the spirit level is accurate by checking that the rear surface of the head is vertical ($\pm 0.3^\circ$) with a calibrated digital inclinometer. If not then adjust the head using the adjuster knob and digital inclinometer until vertical. The integral spirit level shall then be adjusted or replaced as appropriate.
- 3.5.11.9.4 Check the trueness of the head bubble level. Place a digital inclinometer on the rear surface of the head and adjust the bubble to level using the screw. The bubble must not then be altered during the remaining calibration procedure or during use.



Figure 20 HPM in calibration jig with H-point to arm supports

3.5.11.10 Calibration of the HPM/HRMD Unit

Once the H-PM/HRMD assembly is installed into the jig the following measures (with tolerances) shall be taken:

- 3.5.11.10.1 Adjust the HRMD height probe until it is in contact with the forward surface of the jig vertical support. If the lower surface of the height probe contacts the scale at 0mm (± 1 mm) it is deemed to be within

calibration. If this is not possible then the entire HRMD unit shall be checked by the manufacturer (ICBC).



Figure 21 HRMD with backset and height calibration

3.5.11.10.2 Adjust the HRMD backset probe to contact the forward surface of the jig vertical support. The indicated backset shall read 8cm (± 1 mm). If this is not possible then the entire HRMD unit shall be returned to the manufacturer.

3.5.11.11 Attachment of torso angle measuring surface

3.5.11.11.1 Measure the trunk of the left hand weight hanger with a digital inclinometer (Figure 22).



Figure 22 Measurement being taken of the torso angle at the weight hanger trunk by a digital inclinometer

3.5.11.11.2 A calibrated Angle Measuring surface block shall then be attached to ensure the left hand weight hanger trunk to ensure that an angle of 90° ($\pm 0.3^\circ$ is indicated), Figure 23.



Figure 23 Calibrated torso angle measurement surface block attached to trunk of weight hanger arm

3.5.11.11.3 If the angle of the left hand weight hanger is not at 90° (± 0.3) then a calibrated and adjusted surface block shall be installed in place of the standard item.

3.5.11.11.4 Check the angle of the installed calibrated surface block with a digital inclinometer to ensure that it shows a reading of 90° ($\pm 0.3^\circ$).

3.5.11.12 Marking of HPM/HRMD Units

3.5.11.12.1 An indelible metallic self adhesive label shall be attached to the H-PM on LH back pan spine to back pan bracket.

3.5.11.12.2 An identical label shall be attached to the HRMD above the build plate.

3.5.11.12.3 These labels shall have the following information:

- (1) Calibration Date
- (2) Calibration Centre
- (3) Serial numbers of the two units

The label shall also contain the following text: “Calibrated to H-PM/HRMD standard”



Figure 24 The label on the HPM



Figure 25 The label on the HRMD

3.5.11.13 Checking the H-Point Torque

3.5.11.13.1 After the two machines are calibrated together, set the torque on the H-point weight hanger pivot to 3.4 Nm (30 in-lbs). This can be done with a torque wrench.

3.5.12 Preliminary Adjustments to the HRMD and H-Point Machine

3.5.12.1 Remove the head room probe from the H-point machine and install the two washers (supplied with the HRMD) in the spaces remaining on the H-point pivot.

3.5.12.2 To accommodate the manufacturing variances in the SAE H-point machines, the fit of the HRMD on the individual H-point machine shall be confirmed as follows.

- 3.5.12.2.1 Place the H-point machine seat-back and pan in a “sitting position”. Lower the HRMD in position onto the torso weight hangers and onto the top edge of the channel between the torso weight hangers. Before handling the HRMD confirm the knob below the back of the headform is finger tight.
- 3.5.12.2.2 To ensure the HRMD fits easily over the channel between the torso weight hangers and to prevent damage to the spring plungers, the channel must be chamfered in accordance with RONA Kinetics and Associates Ltd. Drawing No. 10045, see below.
- 3.5.12.2.3 If there is fore-aft movement of the headform assembly (with the rear knob on the HRMD finger tight), adjust the spring plungers in the HRMD retainer plate until there is no further movement.

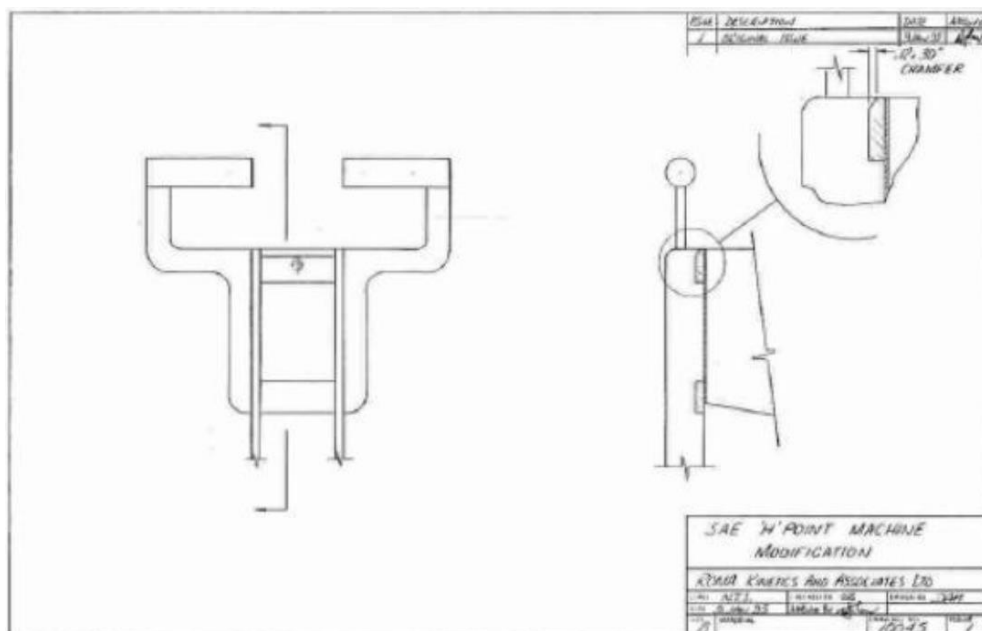

Figure 26 RONA Kinetics and Associates Ltd. Drawing No. 10045 H-point machine modification requirement

3.5.13 Sled pulse specification

3.5.13.1 Definitions

3.5.13.1.1 Offset adjust the accelerometer

In order to make sure that there is no initial acceleration, which result in a non-zero velocity profile, it is required to offset adjust the acceleration signal. It is assumed that this step is a standard procedure for the participating technical service and shall therefore not be discussed into further detail.

3.5.13.1.2 Filter with CFC60

To ensure that low level noise does not influence the results the acceleration signal is filtered with a CFC 60 filter ('endpoints'-method in Diadem). The CFC 60 filter is used according to SAE J211, for sled acceleration signals.

3.5.13.1.3 Definition of T_0

T_0 is defined as the time before the CFC60 filtered sled acceleration reaches 1.0g. The relevant times for the low, medium and high pulses are 4.6ms, 5.8ms and 3.7ms respectively.

3.5.13.1.4 Definition of T_1

T_1 is defined as the time when the sled acceleration for the first time is $> 1g$. Both the initial onset of the pulse and specific low acceleration disturbances ($< 0.5g$) heavily influence the behavior at the start of the pulse. For that reason, it is in practice not possible to identify the actual start of the pulse. Acceleration levels higher than 1g however are unmistakably a direct result of the pulse on the sled. As such, the moment in time when the sled acceleration crosses 1g can be uniquely and easily be found.

3.5.13.1.5 Definition of TEND

TEND is defined as the time when the sled acceleration for the first time is $< 0g$

3.5.13.1.6 Definition of dT

dT is defined as the time span between TEND and T_0

$$dT = TEND - T_0$$

3.5.13.1.7 Definition of dV

dV is defined as the difference between the maximum and minimum sled velocity between T_0 and TEND.

3.5.13.2 Low Severity Sled Pulse Requirements

The sled acceleration must be within the corridors for the complete time interval from 0ms to 150ms as illustrated in Figure 27. The corridor data points are detailed in Table 3 along with additional requirements for the low severity sled pulse.

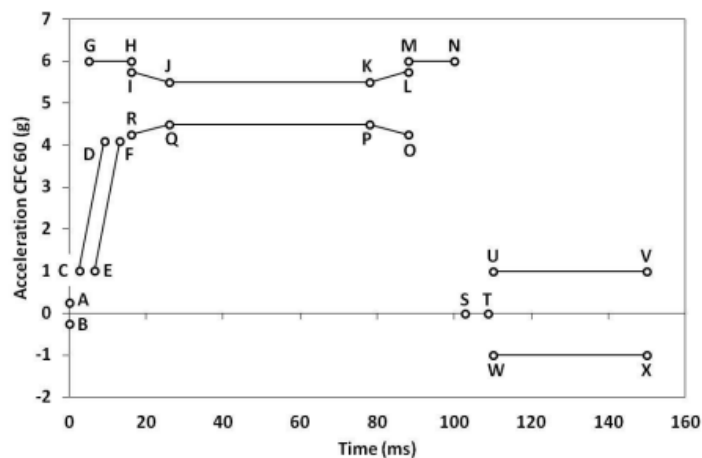

Figure 27 Low severity pulse corridors

Table 3 Low severity pulse requirements

Parameter	Requirement	Limits +/-	Unit		
Velocity change dV	16.10	0.80	km/h		
Mean acceleration A _{mean}	42.35	4.5	m/s ²		
Maximum acceleration A _{max}	5.00	0.5	g		
	Time (ms)	Acceleration (g)		Time (ms)	Acceleration (g)
A	0	0.25	M	88	6.00
B	0	-0.25	N	100	6.00
C	2.6	1.0222	O	88	4.25
D	9.1	4.0982	P	78	4.50
E	6.6	1.0222	Q	26	4.50
F	13.1	4.0982	R	16	4.25
G	5	6.00	S	102.8	0.00
H	16	6.00	T	108.8	0.00
I	16	5.75	U	110	1.00
J	26	5.50	V	150	1.00
K	78	5.50	W	110	-1.00
L	88	5.75	X	150	-1.00

The target rise of the low severity pulse has been calculated using the following formula:

$$\frac{A_{\max}}{2} \left\{ 1 - \cos \left(\frac{(t)\pi}{15.4} \right) \right\}$$

To establish the rise corridor C, D E & F, the portion of the target pulse from 4.6ms to 11.1ms is time shifted by -2.0ms for points C & D and +2.0ms for points E & F. This corridor shall be calculated between time (t) = 4.6ms to 11.1ms.

3.5.13.3 Medium Severity Sled Pulse Requirements

The sled acceleration must be within the corridors for the complete time interval from 0ms to 150ms as illustrated in Figure 28. The corridor data points are detailed in Table 4. The data points for the rise corridor, C, D E & F, are described in Table 5.

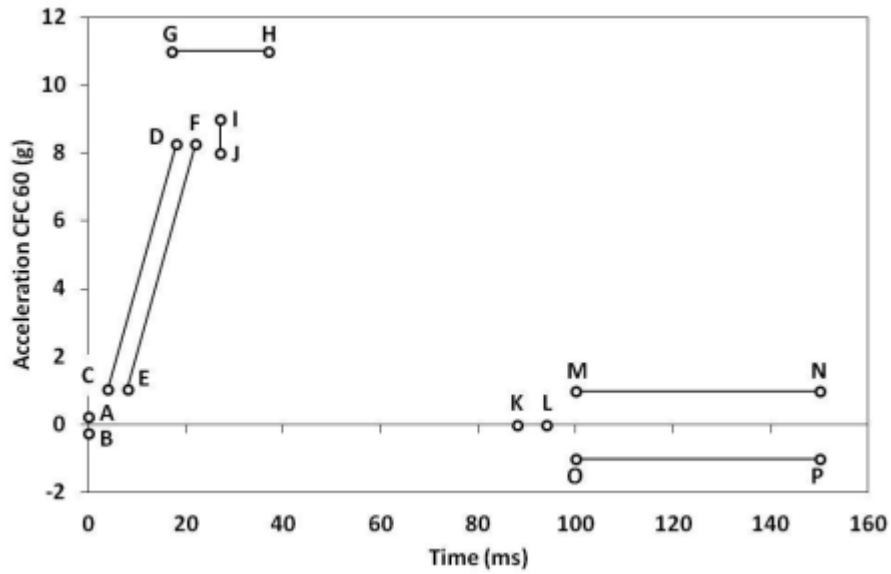

Figure 28 Medium severity pulse corridors

Table 4 Medium pulse requirements

Parameter	Requirement	Limits +/-	Unit	
Velocity change dV	15.65	0.80	km/h	
Mean acceleration A _{mean}	47.85	4.00	m/s ²	
	Time (ms)	Acceleration (g)		
			Time (ms)	
			Acceleration (g)	
A	0	0.25	I 27	8.00
B	0	-0.25	J 27	9.00
C	4	1.0531	K 88	0.00
D	18	8.2705	L 94	0.00
E	8	1.0531	M 100	1.00
F	22	8.2705	N 150	1.00
G	17	11.00	O 100	-1.00
H	37	11.00	P 150	-1.00

Table 5 Medium pulse rise corridor

Time (ms)	Acceleration (g)	Time (ms)	Acceleration (g)
(C) 4	1.0531	(E) 8	1.0531
5	1.3751	9	1.3751
6	1.7443	10	1.7443
7	2.1608	11	2.1608
8	2.6230	12	2.6230
9	3.1276	13	3.1276
10	3.6691	14	3.6691

11	4.2406	15	4.2406
12	4.8336	16	4.8336
13	5.4384	17	5.4384
14	6.0446	18	6.0446
15	6.6414	19	6.6414
16	7.2181	20	7.2181
17	7.7645	21	7.7645
(D) 18	8.2705	(F) 22	8.2705

3.5.13.4 High Severity Sled Pulse Requirements

The sled acceleration must be within the corridors for the complete time interval from 0ms to 150ms as illustrated in Figure 29. The corridor data points are detailed in Table 6 along with additional requirements for the high severity sled pulse.

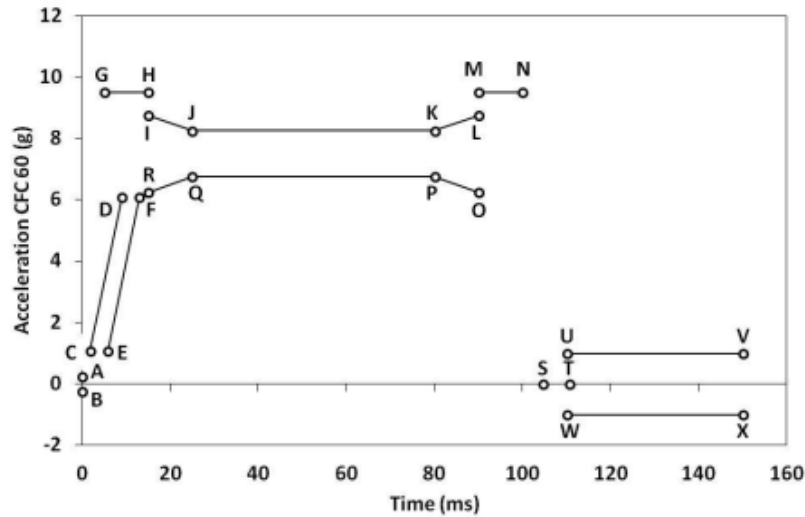

Figure 29 High severity pulse corridors

Table 6 High pulse requirements

Parameter	Requirement	Limits +/-	Unit		
Velocity change dV	24.45	1.2	km/h		
Mean acceleration Amean	63.15	4.85	m/s ²		
Maximum acceleration Amax	7.50	0.75	g		
	Time (ms)	Acceleration (g)	Time (ms)	Acceleration (g)	
A	0	0.25	M	90	9.50
B	0	-0.25	N	100	9.50
C	1.8	1.0714	O	90	6.25
D	9	6.0880	P	80	6.75

E	5.8	1.0714	Q	25	6.75
F	13	6.0880	R	15	6.25
G	5	9.50	S	104.7	0.00
H	15	9.50	T	110.7	0.00
I	15	8.75	U	110	1.00
J	25	8.25	V	150	1.00
K	80	8.25	W	110	-1.00
L	90	8.75	X	150	-1.00

The target rise of the low severity pulse has been calculated using the following formula:

$$\frac{A_{\max}}{2} \left\{ 1 - \cos \left(\frac{(t)\pi}{15.4} \right) \right\}$$

To establish the rise corridor C, D E & F, the portion of the target pulse from 3.8ms to 11.0ms is time shifted by -2.0ms for points C & D and +2.0ms for points E & F. This corridor shall be calculated between time (t) = 3.7ms to 11.0ms.

3.5.14 Seat Movement Definitions

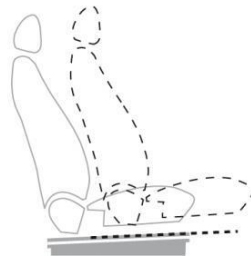

Seat Track: An adjustment that moves the entire seat (seat cushion and seat back) in the fore and aft directions.

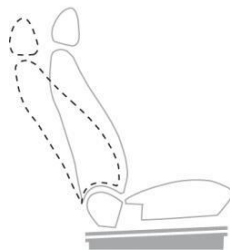

Seatback: An adjustment that rotates the entire seat back, independently of the seat cushion, about a pivot at the seat back/seat cushion joint, therefore, changing the angle of the seat back relative to the seat cushion.

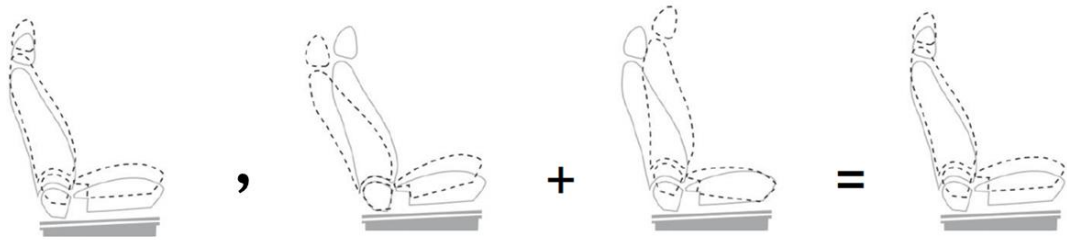

2-way (one control)

4-way (toggle or multiple knobs)

Seat Height: An adjustment that moves the entire seat vertically (seat cushion and seat back in unison). This adjustment must keep the angle of the seat cushion similar relative to the ground. This can be one control (2-way) that moves the whole seat in unison or a combination of controls (4-way – a toggle or multiple knobs) that, when used together, keep the angle of the seat cushion the similar relative to the ground.

NOTE: It is not possible to have 4-way seat height and seat tilt.

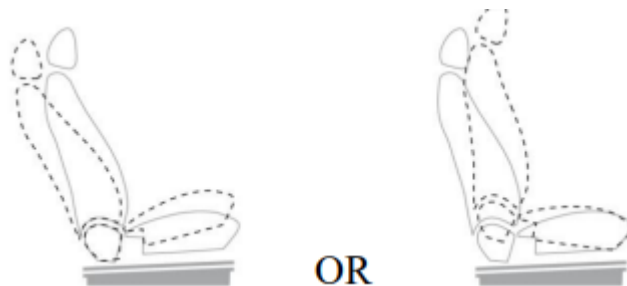

Seat Tilt: An adjustment that rotates the entire seat (seat cushion and seat back in unison). This adjustment rotates a seat in such a way to significantly change the angle of the seat cushion, relative to ground, from its full-down position. This adjustment can move either the front or rear of the seat in order to change the angle.

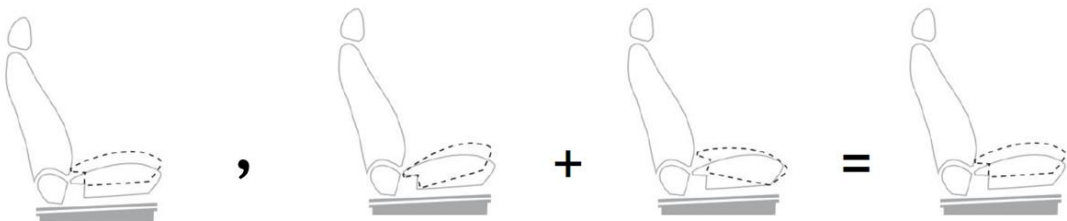

2-way (one control)

4-way (toggle or multiple knobs)

Seat Cushion Height: An adjustment that moves the seat cushion vertically, independent of the seat back, while keeping angle of the seat cushion similar relative to the ground. This can be one control (2-way) that moves the whole seat cushion in unison or a combination of controls (4-way – a toggle or multiple knobs) that, when used together, keep the angle of the seat cushion similar relative to the ground.

NOTE: It is not possible to have 4-way seat cushion height and seat cushion tilt.

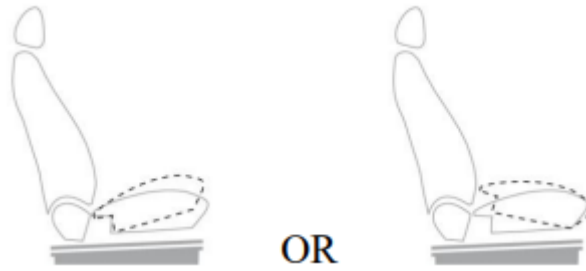

Seat Cushion Tilt: An adjustment that moves the seat cushion, independent of the seat back, in such a way to significantly change the angle of the seat cushion, relative to ground, from its full-down position. This adjustment can move either the front or rear of the seat cushion in order to change the angle.

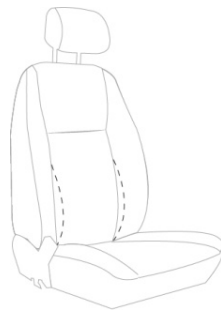

Lumbar Support: An adjustment that causes the lower centre portion of the seat back to protrude in order to provide support to the lumbar section of an occupant's spine.



Upper Seat Back: An adjustment that rotates only the upper portion of the seat back about a pivot point in the seat back. This adjustment will change the angle of the upper seat back relative to the lower portion of the seat back.

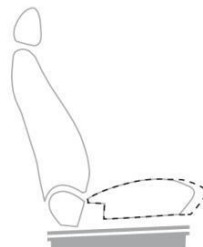

Cushion Extension: An adjustment that moves or extends a portion of the seat cushion forward so that the overall length of the cushion can be increased.



Side Bolsters: An adjustment that moves the sides of the seat back or seat cushion so that the contour of the seat can be changed.

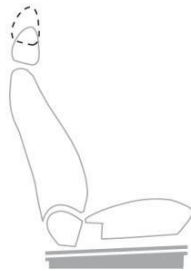

Head Restraint Height: An adjustment that moves the head restraint vertically.



Head Restraint Tilt: An adjustment that moves the head restraint horizontally.