

**Ministry of Transportation and  
Communications**

**Taiwan New Car Assessment Program  
(TNCAP)**

**Second Version**

**3.8 Testing Protocol – Child Occupant  
Protection**

V2.1  
Nov 2025

## TABLE OF CONTENTS

3.8.1 Installation of Top Pick List Child Restraints .....	3
3.8.2 Dynamic Assessment .....	12
3.8.3 Angle Measuring Device.....	24

### 3.8.1 Installation of Top Pick List Child Restraints

All combinations of CRS and vehicle seat position will be checked by installing the CRSs from the top pick list on all seating positions (excluding driver). If any outboard seating positions are identical (adult belts, anchorages, etc) then installation may be performed on one side only. Where there is any asymmetry in a vehicle, including sliding doors, B-pillar positions etc. then all seating positions must be assessed individually.

A CRS from the top pick list that must be installed using more than one installation mode or that is equipped with an anti-rotation device must meet the requirements of all applicable sections for a successful installation. For example, a CRS that must be installed using the adult belt and ISOFIX must meet the full requirements of both Sections 3.8.1.2 and 3.8.1.3 for a successful installation.

When installing each CRS in the vehicle, any simple instructions relating to the preparation of either the vehicle or CRS that are provided in the CRS and/or vehicle handbook will be followed. For example, rear head restraints can be removed if instructed to do in the vehicle handbook for each specific CRS group. It must be clear stated that head restraints must not be removed when using booster cushions only.

The vehicle seating position is considered as compatible with the CRS fitted as long as the conditions described in the following sections are met.

#### 3.8.1.1 Assessment of Problem-Free Installation & Requirements for all CRS

##### 3.8.1.1.1 Ease of Installation in Car

This part of the assessment is to verify the vehicle's ability to allow for easy installation of a range of different CRS by evaluating its provision of sufficient space and access. This does not include fastening the CRS to the vehicle, only positioning on the rear or front seat in preparation for fastening.

##### 3.8.1.1.1.1 Initial Vehicle Settings Installations on the Rear Seat:

- (1) The front row seats shall initially be set in the TNCAP Frontal ODB impact test position.
- (2) The front seats may be adjusted during the assessment. The adjustments allowed are limited to normal day-to-day adjustments to ensure the best possible installation. For the front passenger seat, the full range of fore/aft movement is permissible to create sufficient space for the seat to be installed. The seatback angle must be no further forward than a torso angle of 15 degrees. The full range of seat height is permitted.
- (3) For the driver's seat, the fore/aft adjustment must be no further forward than mid between fully forward and the 95<sup>th</sup> percentile positions. The seatback must be no further forward than a torso angle of 15 degrees. The full range of seat height is permitted.

- (4) It is acceptable to utilize any ‘easy entry’ function in conjunction with the fore/aft adjustment to move the front seat forward and allow access to the rear seats.
- (5) Vehicles with three seat rows shall have the row in front of the seat row being assessed positioned as in (2).
- (6) Vehicles with adjustable rear seats shall initially be set in the position recommended by the manufacturer in the TNCAP Frontal ODB impact test. The flat folded position of a seat is not considered as an in use position. Normal day-to-day adjustments will also be permitted as defined in (2).
- (7) Head restraints shall initially be set to the lowest/not in use position but the full range of height adjustment is considered as a day to day adjustment. However, head restraint removal is permitted but this must be clearly detailed in the vehicle handbook. It must be clear that head restraints must not be removed when using booster cushions only.
- (8) Movable arm rests shall be positioned so as not to interfere with the CRS installation.
- (9) Where the front seat interacts with the steering wheel, for example with easy entry functions, the steering wheel shall be set to mid/mid.

#### 3.8.1.1.1.2 CRS Placement Procedure:

- (1) Where necessary, prepare the CRS for installation by lengthening straps and top-tethers so they are accessible once the CRS is in place.
- (2) Pass the CRS through the relevant occupant entry door. Vehicles with moveable roofs shall have the roof closed during this assessment. No other access routes shall be used, such as the rear hatch/boot.
- (3) If the CRS cannot be easily placed in the vehicle due to the position of the front seats, adjust the front seat to allow CRS placement. Following this, the driver’s seat shall then be repositioned back to a position meeting the requirements defined in 3.8.1.1.1.1(3). The front passenger seat does not need to be adjusted further from the positioned defined in 3.8.1.1.1.1(2).
- (4) For CRSs that allow the child to be carried in the seat, the orientation of the CRS may be changed by up to 40 degrees about its axes (x, y,) to enable the CRS to fit into the vehicle. For CRSs that are not intended as infant carriers then any orientation may be used to place the CRS in the vehicle. Infant carriers must be installed with any handles in the carrying position.
- (5) Where the CRS contains multiple parts, e.g. base and seat, then both items may be installed sequentially and assessed in the same way.

(6) For CRS that do not allow installation with the child in the CRS, there must be sufficient space within the vehicle to allow an adult to place a child in the CRS and attached any harnesses or tighten any webbing. This will be assessed using the appropriate sized child dummy.

The vehicle meets the requirements if all of the following are met:

- (7) The CRS can be placed on the rear seats without excessive force, difficulty or interaction with the door aperture.
- (8) After adjustment of the front seat, it does not prevent or interfere with correct placement of the CRS. It must be possible to return the driver's seat to a position meeting the requirements defined in 3.8.1.1.1(3). An easy entry function may be used.
- (9) Where applicable, the easy entry function allows the front seat to return and lock in a position allowed in day to day use defined in 3.8.1.1.1.1.
- (10) If there is sufficient space within the vehicle for a child to be correctly placed in the CRS and the child is not prevented from sitting normally in the CRS.

The vehicle would not meet the requirements if any of the following occur:

- (11) The child seat or base does not individually fit through the door aperture.
- (12) The CRS cannot be placed in the vehicle.
- (13) The CRS must be rotated more than the permissible amount to enable placement or where applicable.
- (14) Vehicle structures prevent a child from being placed correctly in the CRS.
- (15) The driver's seat cannot be returned to the position defined in 3.8.1.1.1(3). The passenger's seat cannot be returned to the position defined in 3.8.1.1.1(2).
- (16) There is insufficient space within the vehicle to allow the child to occupy the CRS as normal.

### 3.8.1.2 Requirements for Seat Belt Mounted CRSs

#### 3.8.1.2.1 Use of 3-Point Belts

##### 3.8.1.2.1.1 Ease of Fastening Seatbelt Procedure:

- (1) Once placed in the vehicle, the CRS shall be positioned along the centreline of the chosen seating position.
- (2) Route the adult seatbelt around the CRS in accordance with the instructions on the CRS.
- (3) Engage the buckle tongue into the buckle.
- (4) If necessary, some small movement of the CRS is permitted to expose the seat belt buckle. This is limited to rotation of up to 20 degrees about the x and z-axes or 50mm lateral movement from the seat centreline. After

buckling the belt, the CRS shall be moved back to the seat centreline if possible.

- (5) For CRS that are not equipped with integral harnesses an appropriate sized dummy shall be placed in the CRS during this procedure.

The vehicle meets the requirements if all of the following are met:

- (6) The tongue can be engaged in the buckle with the use of only one hand and without the need to reposition the CRS more than permitted in 3.8.1.2.1.1(4) to enable access to the buckle, or the tongue can be engaged using two hands to insert the buckle, where one supports the buckle, and the other is used to insert the tongue.
- (7) The adult seat belt adjacent to the assessed seating position does not prevent installation of the CRS or lead to any instability.
- (8) With the CRS installed, the three point belt on another seating position in that same row shall be capable of restraining another occupant.

The vehicle would not meet the requirements if any of the following occur:

- (9) The belt cannot be buckled due to insufficient belt length.
- (10) The belt length is such that the CRS is not in the correct position on the seat.
- (11) The CRS has to be moved or rotated more than prescribed above to allow access to the buckle, e.g. the buckle is positioned underneath the CRS.
- (12) The installation of the CRS means that an adult cannot occupy another seating position on that row, for example due to limited space or interference with the adult belt system.

#### 3.8.1.2.1.2 Ease of Tightening Belt (Ease of Operating the Lock-off Clip)

This assessment is of the vehicle's ability to be able to correctly restrain the CRS using the adult belt systems.

Procedure:

- (1) With the seat belt buckled and belt routed correctly around the CRS, tension shall be introduced into the adult seatbelt by pulling on the diagonal section of the belt in the direction of the reel.
- (2) Remove the slack in the lap belt by pulling on the diagonal belt near the buckle with a force of 150N.
- (3) A measurement of seatbelt tension will be required for this installation.
- (4) For seats that do not have an integral harness, a child dummy of the largest appropriate size shall be placed in the CRS during this process.

The vehicle meets the requirements if all of the following are met:

- (5) When 150N is applied to the diagonal section of the adult belt, the slack in all parts of the lap section is removed.

- (6) The CRS is held firmly against the seat back and seat base by the adult belt.
- (7) Movement of the CRS base or back, in any direction, must result in increasing tension within the belt system, e.g. with forward movement of the CRS. The belt reel shall be prevented from spooling out during this check.
- (8) Where applicable, the seat belt must restrain the dummy and the seat correctly.

The vehicle would not meet the requirements if any of the following occur:

- (9) When slack has been removed from the belt system, the buckle tongue stop prevents the lock off from operating correctly.
- (10) It is not possible to remove the slack in any part of the lap section.

#### 3.8.1.2.2 Additional Tethers

Where the chosen CRS is equipped with an additional tether apply the relevant assessment outlined in Section 3.8.1.4 before moving on to the next section.

#### 3.8.1.2.3 Obstruction & Stability of the CRS Procedure:

- (1) The CRS shall be installed in the vehicle with the seat belt buckled and any tethers attached as per the previous steps. The largest appropriate P or Q dummy shall also be installed in the CRS.
- (2) Any comfort adjustments on the CRS shall be changed up to a maximum stature of 135cm. E.g. incline, recline, head restraint height etc. Adjustments for children larger than 135cm will not be used.
- (3) Check any contact points between the CRS, dummy and vehicle.
- (4) The CRS shall be rocked from side to side about the x axis over a 10° to 15° arc. No other restraint shall be placed on the CRS during rocking.
- (5) The CRS shall be pulled toward the front of the vehicle and twisted about the z axis.
- (6) The CRS shall be returned to the initial position with the belt tightened as per Section 3.8.1.2.1.2 and a force of 100N shall be applied perpendicular to the CRS in the y direction at the shoulder level of the dummy. This assessment will not be applied to the Group 0+ CRS.
- (7) The CRS shall be returned to the initial position with the belt tightened as per Section 3.8.1.2.1.2 and a force of 100N shall be applied perpendicular to the CRS in the y direction at a small distance above the vehicle seat. This assessment will not be applied to the Group 0+ CRS.

The vehicle meets the requirements if all of the following are met:

- (8) The vehicle interior can accommodate installation of the CRS in all orientations and adjustments up to a stature of 135cm without interaction

with other parts of the vehicle. E.g. booster seats with adjustable head restraints must not be restricted by the rear head restraints or C-pillars.

- (9) The presence of vehicle head restraints does not prevent correct installation of the CRS and does not lead to significant forwards rotation of the CRS or create lateral instability.
- (10) Contact between the CRS and vehicle interior is permitted provided that the CRS is correctly installed, stable and is not rotated by more than 5 degrees.
- (11) The measured backrest angle of the CRS is not forwards from vertical. This can be measured using the device described in 3.8.3.
- (12) The vehicle interior provides stable support for the CRS in the selected installation modes and adjustments. E.g. the CRS back or base tensioning system must be in contact with the vehicle seat base and seat back cushions.
- (13) The CRS sits flat on the seat base cushion and, for forward facing CRS, is supported by the seat back and/or head restraint.
- (14) With the load applied to the CRS the rotation about the X axis does not exceed 20 degrees and the CRS remains secured and has a tendency to return back to the original position.
- (15) As any load is applied, the tension in the belt system increases with the displacement of the CRS.

The vehicle would not meet the requirements if any of the following occur:

- (16) The CRS does not sit correctly on the seat base cushion or is not sufficiently supported by the seat back and/or head restraint.
- (17) The vehicle interior can accommodate installation of the CRS with only limited adjustments of the CRS i.e. tilt or adjustable backrests cannot be used due to interference from the vehicle.
- (18) The vehicle interior encroaches into the space in which the child dummy sits resulting in any contact with the dummy head or legs. For example, where the roof is too low or the knees or tibia are against the back of the front seat. Contact with the head and head restraint or with the toes/feet and seat back is acceptable.
- (19) Any part of the vehicle interior, including bolsters, arm rests, pillars obstruct the CRS or prevents a particular adjustment from being made. E.g. C-pillar, roof or rear head restraints prevent correct installation of CRS.
- (20) With the appropriate child dummy installed, the size of the car limits the possible age groups that can be installed.
- (21) There is limited support offered to the CRS through lack of contact with the supporting structures, e.g. large side bolsters prevent the CRS from



sitting flat on the seat base.

- (22) When load is applied to the CRS it can move more than the allowed amount or the CRS can move without increasing tension on the belt system.

### 3.8.1.3 Requirements for ISOFIX CRS

#### 3.8.1.3.1 Insert and Locking ISOFIX Probes (Only)

This is an assessment of the ease of which the CRS ISOFIX probes can be engaged with the vehicle ISOFIX anchorages. It does not include assessment of any other tethers, straps or supports.

Procedure:

- (1) The position and orientation of the vehicle anchorages shall be identified and prepared for CRS attachment. Simple, preparatory actions such as sliding a seat belt away from the anchorage, lifting a dedicated flap or covering to expose the anchorage are permissible. Plastic guide funnels supplied with CRS will NOT be used.
- (2) The CRS shall be placed on the seat centreline, the CRS ISOFIX probes shall be made ready for attachment to the vehicle.
- (3) The CRS and probes shall be pushed toward the anchorages until they are engaged, keeping the CRS on the vehicle seat cushion. Lifting of the CRS from the seat base is not allowed, but some rotation/tilting of the CRS is permissible provided there is still contact with the seat cushion. Separate support frames and bases (if available) may be lifted.
- (4) If necessary, 50mm of lateral movement of the CRS is permitted to allow engagement with the ISOFIX anchorages. Where the CRS has movable ISOFIX probes, they may be adjusted to facilitate engagement provided the CRS remains on the vehicle seat.
- (5) Where the adult belt prevents engagement with the ISOFIX anchorages, it is permissible to reposition the belt to improve access provided that the belt does not have to be held in that position.

The vehicle meets the requirements, once preparatory steps have been performed, if all of the following are met:

- (6) Each vehicle ISOFIX anchorage can be easily engaged. For example, the anchorages are easily accessible or they are equipped with permanent guidance (plastic funnel, fabric slit, etc) which helps the CRS ISOFIX probes align with the vehicle anchorages avoiding any obstruction from the seat, such as the fabric or cushion etc.
- (7) For CRS where the probes are attached to the shell, the CRS can be attached to the vehicle by simply pushing it toward the anchorages, with some tilting but without any other actions that are not described on the CRS itself.

- (8) If the CRS uses a separate support frame, the frame can be easily engaged onto the ISOFIX anchorages without removing fabric, etc.
- (9) With the CRS installed, one of the three point belts on another seating position in that same row shall be capable of restraining one other occupant. The vehicle would not meet the requirements if any of the following occur:
  - (10) If the anchorages cannot be engaged without further actions. For example, where the seat cushions have to spread apart by hand in order to create access to the anchorages.
  - (11) The CRS has to be lifted off the seat cushion to allow engagement with the anchorages. Lifting of separate support frames is permissible.
  - (12) Any part of the seat, seat cushion, seat belt or buckle prevents attachment of the CRS.
  - (13) Where the CRS probes are clearly misaligned with the ISOFIX anchorages.
  - (14) Where physical guidance is required, such as plastic funnels, they are not permanently attached to the vehicle.

#### 3.8.1.3.2 Additional Tethers and/or Support Leg

Where the chosen CRS is equipped with an additional tether or support leg apply the relevant assessment outlined in Section 3.8.1.4 before moving on to the next section.

#### 3.8.1.3.3 Obstruction & Stability of the ISOFIX CRS

The principle here is identical to that of Section 3.8.1.2.3. Procedure:

- (1) The CRS shall be installed in the vehicle with ISOFIX and any tethers or support legs attached. A child dummy of the appropriate size shall also be installed in the CRS.
- (2) Any comfort adjustments on the CRS shall be changed up to a maximum stature of 135cm. E.g. incline, recline, head restraint height etc. Adjustments for children larger than 135cm will not be used.
- (3) Check any contact points between the CRS and vehicle.
- (4) The CRS shall be pulled toward the front of the vehicle and twisted about the z-axis.

The vehicle meets the requirements if all of the following are met:

- (5) The vehicle interior can accommodate installation of the CRS in all orientations and seat adjustments up to a stature of 135cm without interaction with other parts of the vehicle. E.g. booster seats with adjustable head restraints must not be restricted by the rear head restraints or C-pillars.
- (6) The presence of vehicle head restraints must not lead to significant forwards rotation of the CRS or create lateral instability.
- (7) Contact between the CRS and vehicle interior is permitted provided that the

- CRS is correctly installed, stable and is not rotated by more than 5 degrees.
- (8) The measured backrest angle of the CRS is not forwards from vertical. This can be measured using the device described in 3.8.3.
  - (9) The vehicle interior provides stable support for the CRS and its attachments with the vehicle in all installation modes and adjustments.
  - (10) There is little or no rotation of the CRS about all axes.

The vehicle would not meet the requirements if any of the following occur:

- (11) The vehicle interior can accommodate installation of the CRS with only limited adjustments of the CRS i.e. tilt or adjustable backrests cannot be used due to interference from the vehicle.
- (12) Where applicable, the vehicle interior prevents the seat shell from engaging on the frame or base without the use of excessive force.
- (13) The vehicle interior encroaches into the space in which the child dummy sits resulting in any contact with the dummy head or legs. For example, where the roof is too low or the knees or tibia are against the back of the front seat. Contact with the head and head restraint or with the toes/feet and seat back is acceptable.
- (14) Any part of the vehicle interior, including bolsters, arm rests, pillars, obstructs the CRS or prevents a particular adjustment from being made. E.g. C-pillar or rear head restraint prevents correct installation of CRS.
- (15) With the appropriate child dummy installed, the size of the car limits the possible age groups that can be installed.
- (16) There is limited support offered to the CRS through lack of contact with the supporting structures. E.g. poor or inadequate support is provided to CRS support legs or the support legs cannot be correctly positioned.

#### 3.8.1.4 CRS Installed Using Additional Tethers, Straps and Support Legs

##### 3.8.1.4.1 Ease of Use of Tethers & Straps

This is an assessment of the ease of which the additional tether anchorages such as top tethers can be engaged with the vehicle, where applicable.

Procedure:

- (1) Once the CRS has been attached to the vehicle with the belt or ISOFIX, any additional tethers, straps and corresponding anchorages or brackets shall be readied. Simple, preparatory actions such as lifting a dedicated flap or covering to expose the attachment point are permissible.
- (2) The removal or repositioning of a parcel shelf or tonneau cover is allowable. It must be possible to replace these parts once the CRS installation has been completed.
- (3) Head restraints may be repositioned or removed for CRS installation if

instructed in the vehicle handbook.

The vehicle meets the requirements if all of the following are met:

- (4) The top tether can be engaged and tightened easily, without having to carry out any further actions other than already mentioned.
- (5) Where equipped, any additional tethers can be easily attached to the anchorage and easily tightened, for example the front seat rail or any other attachment points.

The vehicle would not meet the requirements if any of the following occur:

- (6) The strap(s) or tether(s) cannot be engaged without any further actions of vehicle adjustments, e.g. it would not be acceptable to tilt the rear seat forwards to be able to engage the tether.
- (7) The strap(s) or tether(s) pass through luggage or occupant space and prevent the use of other parts of the vehicle, including rear seats. Top tether straps that remain above the top of the vehicle seat back are acceptable provided they do not obstruct any other space required for occupants or interfere with the use of the adult belts.
- (8) The strap(s) or tether(s) obstruct the function or movement of other parts of the vehicle, such as the front seats or luggage space.

#### 3.8.1.4.2 Ease of Use of Support Legs

This is an assessment of the vehicles ability to provide adequate support to any support legs, where applicable.

The vehicle meets the requirements if all of the following are met:

- (1) The vehicle provides sufficient space to allow stable placement of any support legs.
- (2) The support leg must be installed in the intended positions, for example fully locked out.
- (3) The area upon which a support rests must also be capable of providing adequate restraint during an impact as described in the Vehicle Safety Testing Directions “48-2 Safety Belt Anchorage.”

The vehicle would not meet the requirements if any of the following occur:

- (4) Poor or inadequate support is provided to CRS support legs or where the support leg cannot be positioned correctly due to interference from the front seat or other vehicle structures.
- (5) The support leg cannot be fully locked out, or cannot provide the intended level of support for any reason, such as due limited space.

### 3.8.2 Dynamic Assessment

#### 3.8.2.1 CRS for Dynamic Test

The Q6 dummy shall be seated in an appropriate forwards facing CRS for a six

year old child or a child with a stature of 125cm. This will be either the CRS recommended by the vehicle manufacturer, or if there is no recommendation, a suitable CRS from the top pick list. Rearwards facing CRS will not be permitted for the Q6.

The Q10 dummy shall be seated on a booster cushion only. This will be the booster cushion recommended by the vehicle manufacturer. Where the vehicle manufacturer recommends a high back booster with detachable backrest it will be used without backrest. If there is no recommendation for a booster cushion, one will be chosen by TNCAP from suitable options available in the market.

#### 3.8.2.1.1 Integrated CRS

Where a vehicle is equipped with an integrated CRS covering the Q6 and/or Q10 on the rear outboard 2<sup>nd</sup> row test positions, the integrated CRS will be used in the dynamic tests. Integrated CRS will be used even if they are optional equipment.

Where a vehicle is equipped with only one integrated CRS on either outboard position covering both or only one of two child ages, the integrated CRS will be used only where applicable.

#### 3.8.2.2 Dummy Preparation and Certification

##### 3.8.2.2.1 General

In the Frontal ODB impact, a Q6 child dummy shall be installed on the 2<sup>nd</sup> row outboard passenger seat behind the driver. A Q10 child dummy shall be installed on the 2<sup>nd</sup> row outboard passenger seat behind the front passenger.

For the Side AE-MDB impact a Q10 child dummy shall be installed on the 2<sup>nd</sup> row outboard passenger seat behind the driver. A Q6 child dummy shall be installed on the 2<sup>nd</sup> row outboard passenger seat behind the front passenger.

##### 3.8.2.2.2 Certification

- (1) The Q6 and Q10 child dummies shall be re-certified after every TWENTY impact tests (e.g. 10 frontal and 10 side impacts, or any combination of the two test types). Hip shields shall be replaced after every dummy certification, hip liners shall be replaced after every twenty impact tests.
- (2) The Q10 dummy shoulder lateral impact certification test is to be performed with the side impact shoulder kit only.
- (3) If an injury criterion reaches or exceeds its normally accepted limit (eg HIC of 700) then that part shall be re-certified.
- (4) If any part of a dummy is broken in a test then the part shall be replaced with a fully certified component.
- (5) Copies of the dummy certification certificates shall be provided by the technical service as part of the full report for a test.

### 3.8.2.2.3 Additions and Modifications to the Dummies

- (1) The Q6 dummy shall be standard build level A, and the Q10 standard build level C. See the relevant user manual for each dummy.
- (2) The Q10 dummy is used with the full arms for frontal impact testing. The Side Impact Kit including half arms on both sides of the dummy shall be used in the side impact test.

### 3.8.2.2.4 Dummy Clothing

- (1) Each child dummy shall wear their appropriate suits, Q6 part number 033-8000 (with Cordura patches) and Q10 part number 010-8000.
- (2) The Q10 shall be installed with either left and right hand hip shields, part numbers 010-8001 and 010-8002 or a hip liner, part number 010-8000.
- (3) The Q6 shall be installed with either hip shields or a hip liner, part number 033-7160. Hip shields or hip liners may only be used for the Q6 when seated on an integrated CRS.

### 3.8.2.2.5 Dummy Test Condition

#### 3.8.2.2.5.1 Dummy Temperature

- (1) The Q6 and Q10 shall have a stabilized temperature, measured in the chest cavity, of 18°C to 22°C, for at least 1 hour immediately prior to the test.
- (2) The temperature of the dummies shall be measured for at least 5 hours before test at intervals not exceeding 10 minutes and not exceeding 5 minutes before test.
- (3) A copy of the temperature readings is to be supplied as part of the standard output of the test.

#### 3.8.2.2.5.2 Dummy Joints

All constant friction joints shall have their ‘stiffness’ set by the following method:

- (1) Stabilize the dummy temperature by soaking in the required temperature range for at least 5 hours.
- (2) Set the torque on the shoulder screws to obtain a 1g holding force of the shoulder and elbow.
- (3) For the knee joint, the tensioning screw or bolt which acts on the constant friction surfaces shall be adjusted to obtain a 1g holding force.
- (4) The dummy joints shall be set as close as possible to the time of the test and, in any case, not more than 24 hours before the test.
- (5) Maintain the dummy temperature within the permissible temperature range between the time of setting the limbs and up to a maximum of 5 minutes before the time of the test.

#### 3.8.2.2.5.3 Dummy Painting

The dummies shall have masking tape placed on the areas to be painted using the size table below. The tape shall be completely covered with the following colored paints. The paint shall be applied close to the time of the test to ensure that the paint will still be wet on impact.

Child Dummies

Top of Head	Blue
Head-band (colors from left to right)	Red, Yellow, Green

Paint Area Sizes:

Child Dummies

Top of Head	75×75mm square
Headbands	25mm wide, widest circumference at eyebrow level at front, extending to the head C of G at each side

3.8.2.2.6 Post Test Dummy Inspection

The dummies shall be visually inspected immediately after the test. Any lacerations of the skin or breakages of a dummy shall be noted in the test specification. A dummy may have to be re-certified in this case.

3.8.2.3 Dummy Instrumentation

All instrumentation shall be calibrated before the test program. The Channel Amplitude Class (CAC) for each transducer shall be chosen to cover the Minimum Amplitude listed in the table. In order to retain sensitivity, CACs which are orders of magnitude greater than the Minimum Amplitude shall not be used. A transducer shall be re-calibrated if it reaches its CAC during any test. All instrumentation shall be re-calibrated after one year, regardless of the number of tests for which it has been used. A list of instrumentation along with calibration dates shall be supplied as part of the standard results of the test. The transducers are mounted according to procedures laid out in SAE J211. The sign convention used for configuring the transducers is stated in SAE J211 (2007).

The dummies to be used shall be instrumented to record the channels listed in the following tables.

Q10 Dummy

Location	Parameter		Minimum Amplitude	No. of Channels
Head	Accelerations, $A_x A_y A_z$		200g	3
Head tilt sensor (static)	Angle		NA	NA
Upper Neck (OC)	Forces	$F_x F_y$	8.0kN	2

		$F_z$	10.0kN	1
	Moments	$M_x M_y$	90Nm	2
		$M_z$	45Nm	1
Shoulder (side only)	Forces	$F_x F_y$	2.0kN	2
		$F_z$	4.0kN	1
T1 (side only)	Acceleration, $A_y$		200g	1
Chest (T4)	Accelerations, $A_x A_y A_z$		200g	3
	Displacement & Rotation		90mm 40°	4
Lumbar spine (Lower)	Forces	$F_x F_y$	6.0kN	2
		$F_z$	8.0kN	1
	Moments	$M_x M_y$	150Nm	2
		$M_z$	75Nm	1
Pelvis - Sacrum	Accelerations, $A_x A_y A_z$		200g	3
Pelvis – Pubis (side only)	Force, $F_y$		2.0kN	1
Iliac (L & R) (Optional)	Force, $F_x$		9 kN	(2)
	Moment, $M_y$		220 Nm	(2)
Total Channels				30(34)

#### Q6 Dummy

Location	Parameter		Minimum Amplitude	No. of Channels
Head	Accelerations, $A_x A_y A_z$		200g	3
Upper Neck (OC)	Forces	$F_x F_y$	5.0kN 5.0kN	2
		$F_z$	6.0kN	1
	Moments	$M_x M_y$	90Nm	2
		$M_z$	45Nm	1
Chest	Accelerations, $A_x A_y A_z$		200g	3
	Displacement		90mm	1
Iliac (L & R) (Optional)	Force, $F_x$		9kN	(2)
	Moment, $M_y$		220Nm	(2)
Total Channels				13(17)

#### 3.8.2.4 Dummy Positioning and Measurements

The official provisions are written in Chinese, this English edition is for your reference only.



Two CRS's are to be fitted on the rear seat, one suitable for a 10 year old child, the other for a six year old child.

Read the relevant sections of the vehicle handbook and the instructions provided with the child restraint. This is to identify any special features of either the vehicle or the child restraint that are intended to improve performance or may influence installation. Instructions on tightening of the adult seat belt around the child restraint shall be noted, but the installation itself shall follow the procedure below. The use of additional belt guides, clips or other components that are not an integral part of the CRS is prohibited. Belt guides that are fitted to the vehicle must be permanently attached and information on their use must be contained in the vehicle handbook, where this is not the case they **MUST NOT** be used for testing.

#### 3.8.2.4.1 General

Before installing the dummies and child restraint systems, ensure that the passenger compartment adjustments for the rear seats is performed according to section 3.1.5 of the TNCAP Frontal ODB Test protocol and section 3.3.4 of the TNCAP Side Protocol.

Leave the front seats as far forward as possible to ensure easy access.

#### 3.8.2.4.2 Marking Centerlines

Mark the centreline of both of the rear outboard seating positions (including head restraint centreline if necessary) and on the CRS used for test. Markings placed on hard parts of the CRS, rather than seat fabric, are preferable. If an ISOFIX CRS is used no markings are needed.

The vehicle manufacturer shall confirm whether or not the centreline of the head restraints aligns with the centreline of the vehicle's rear seat cushion. Where this is not the case the OEM shall supply details of the seat base centreline in accordance with the rear seat whiplash assessment. Where no information is provided, either the centreline of the head restrains, seat cushion or the ISOFIX anchorages shall be used, whichever is the most appropriate for the CRS installation.

#### 3.8.2.4.3 Q10 Installation

##### 3.8.2.4.3.1 Dummy Preparation

- (1) Attach a foam pad of 125mm x 90mm with a thickness of 20mm  $\pm$ 2mm to the rear of the dummy pelvis, outside the suit, using tape to hold it in place. The pad shall be centred on the midsagittal plane with the upper edge at the same height as the top of the pelvis flesh.
- (2) This pad shall remain on the dummy for the test unless it can be removed without the need to move the dummy.
- (3) The foam pad shall have the following properties:

Density of 152-200kg/m<sup>3</sup>

Compression deflection at 25% of 89-118kPa

#### 3.8.2.4.3.2 Placing the Booster Cushion in the Vehicle

- (1) Place the CRS on the relevant seating position and mark the fore/aft position on the CRS on the side of the CRS and vehicle. Align the CRS with the markings on the vehicle seat cushion and check that there is no interaction between the CRS and side door when it is closed. If there is some interaction, the CRS may be moved inboard by up to 50mm.
- (2) If an ISOFIX CRS is used no markings are needed, the CRS shall be aligned with the anchorages and engaged with the vehicle.

#### 3.8.2.4.3.3 Placing the Q10 Dummy in the Vehicle

- (1) Place the dummy on the booster cushion and ensure that the suit has not moved in the gap between femur and hip by pulling the suit towards the knees.
- (2) Align the dummy and CRS with the marked centerline.
- (3) Buckle the seatbelt. If the buckle is not accessible because of interaction with the CRS, move the CRS and dummy outboards by the minimum distance (with a maximum of 50mm) required to get free access to the buckle. Remove the slack from the webbing but do not tighten the webbing.
- (4) Try to realign the CRS with the marks on the seat cushion. If the CRS cannot easily be aligned with the original marks due to the shape of the vehicle seat or position of the seat belt buckle, then re-mark the new lateral position of CRS relative to vehicle seat.
- (5) Ensure that the rear of the CRS is in contact with the seat back by pressing the CRS backwards against the seat and making sure that the fore/aft markings are still aligned.
- (6) Where applicable, place the hip shields on the Q10 dummy. Ensure that the distance between the hip shields is no less than 154mm. If needed, a large gap shall be used to establish the best fit.

#### 3.8.2.4.3.4 Q10 Dummy Positioning

- (1) Ensure that the dummy's lower back is in contact with the vehicle seat back by bending the dummy's back into an upright position and then rocking the dummy sideways while at the same time pushing the pelvis backwards.
- (2) Ensure that the booster cushion is aligned with the new reference marks.
- (3) Ensure that the dummy is sat on the centreline of the CRS and is not rotated about the vertical axis.

- (4) Push the dummy's shoulders toward the seat back until either the shoulders contact the seat back or the head is in contact with the head restraint.
- (5) The top of the rear head restraint shall be positioned within  $\pm 20$ mm of the top of the dummy head or in the nearest notch above. If the head restraint cannot be raised sufficiently to be within 20mm, put it in the highest position.
- (6) Ensure that the dummy is sitting in an upright position and is aligned with the centreline marks on the head restraint (if applicable) or is parallel to the marks of the centreline.
- (7) Ensure that the CRS position did not change relative to the marked position.

#### 3.8.2.4.3.5 Legs

- (1) Position the femurs straight forward with a distance of 130mm  $\pm 5$ mm between the centres of the knees. If the CRS prevents this gap from being achieved, position the knees as close to the target values as possible.
- (2) Where possible, allow the lower legs to rest naturally. The tibias shall be parallel to the vehicle centreline and the feet shall be separated by the same distance as the knees.
- (3) Record the pelvic angle using the tilt sensor in the test details.

#### 3.8.2.4.3.6 Position of the Front Seat

- (1) Reposition the front seat 30mm forward of its test position. If there is no notch at this position, set the seat in the nearest notch forwards of 30mm.
- (2) During repositioning, check for interaction between the Q dummy lower legs, feet and the front seat.
- (3) With the front seats 30mm forward, if there is no contact between the front of the dummy toes and the seat in front, it is acceptable for the top of the foot/toes to contact the underside of the front seat, reposition the front seats in their test positions and proceed to belt routing. The interaction between the Q dummy lower legs, feet and the front seat is acceptable. Record the pelvic angle.
- (4) If there is contact between the dummy and the front seats when they are 30mm forward of their test position, follow the steps below to limit contact between dummy and front seat. Note: this is not relevant if there is only contact between the top of the foot/toes and the underside of the front seat.
  - (A) Try to reposition the feet and tibias by pushing them beneath the front seat or rotating the tibias about the Z axis. If this is not sufficient then:

(B) Move the pelvis of the dummy forwards, while keeping the CRS in place, until there is no more contact with the seat in front. It is permitted to change the pelvic angle up to 5 degrees relative to the initial pelvic angle. This shall be done in incremental steps until the contact between the toes and front seat is removed. It is acceptable for the top of the foot/toes to contact the underside of the front seat. Record the final pelvic angle.

(5) When the dummy toes remain in contact with the front seat after repositioning the dummy as mentioned above, the vehicle will be treated as limited rear space for that particular test see Section 3.8.2.5 it is acceptable for the top of the foot to contact the underside of the front seat.

(6) The front seat must be returned to the test position.

#### 3.8.2.4.3.7 Belt Routing

(1) Follow the CRS installation instructions when routing the seat belt and ensure that the belt is routed correctly through any necessary belt guides.

(2) Remove the slack of the lap belt by pulling on the diagonal belt near the buckle with a force of 150N.

(3) Ensure that the belt is not twisted in the guidance of the booster cushion.

(4) The belt shall initially be positioned over the IR-TRACC (upper for Q10) if possible, a load of 50N shall be applied to the diagonal section of the belt in towards the D-loop to achieve a natural and flat position across the chest. The belt may have moved away from the initial position, there is no need for further adjustment.

(5) The use of any non permanent belt guides or clips on either the vehicle or CRS is prohibited.

(6) There shall be no tape stickers applied to the diagonal section of the adult belt.

#### 3.8.2.4.3.8 Arms

(1) The upper arm shall be positioned parallel to the chest. The measurements shall be taken on the neoprene suit along the front surface of the arm (bicep) and between the two IR-TRACCs on the chest.

(2) For the frontal impact, position the lower arms parallel to the upper legs resting on the booster cushion or armrest as close as possible to the side of the femur. The elbows shall be kept as close as possible to the torso. Where possible, the tip of fingers shall be in x-direction in line with the screws of the knee joint. Measure and record the upper arm angle.

#### 3.8.2.4.3.9 Dummy Marking

Once the dummy has been correctly positioned, the two IR-TRACC holes

shall be clearly marked on the suit of the dummy.

#### 3.8.2.4.3.10 Dummy Measurements

The following measurements are to be carried out prior to test but after positioning procedures have been carried out.

Q10	
A	Top of head to roof (vertically)
B	Head CoG to door/window (horizontal)
C	Shoulder (pivot point) to door/window (horizontal)
D	Lower rib to door (horizontal)
E	Hip joint (femur mounting hole) to door (horizontal)
F	Hip joint (femur mounting hole) to floor (vertical)
$\alpha$	Head angle (where fitted)
$\beta$	Pelvic angle (tilt sensor)

#### 3.8.2.4.4 Q6 Installation

##### 3.8.2.4.4.1 Placing the CRS in the Vehicle

- (1) Place the CRS on the relevant seating position and mark the fore/aft position on the CRS on the side of the CRS and vehicle. Align the CRS with the markings on the vehicle seat cushion and check that there is no interaction between the CRS and side door when it is closed. If there is some interaction, the CRS may be moved inboard by up to 50mm.
- (2) If an ISOFIX CRS is used no markings are needed, the CRS shall be aligned with the anchorages and engaged with the vehicle.

##### 3.8.2.4.4.2 Placing the Q6 Dummy in the Vehicle

- (1) Place the dummy in the booster seat and ensure that the suit has not moved in the gap between femur and hip by pulling the suit towards the knees.
- (2) Align the dummy and CRS with the marked centreline.
- (3) Buckle the seatbelt. If the buckle is not accessible because of interaction with the CRS, move the CRS and dummy outboards by the minimum distance (with a maximum of 50mm) required to get free access to the buckle. Remove the slack from the webbing but do not tighten the webbing.
- (4) Try to realign the CRS with the marks on the seat cushion. If the CRS cannot easily be aligned with the original marks due to the shape of the vehicle seat or position of the seat belt buckle, then re-mark the new

lateral position of CRS relative to vehicle seat.

- (5) Ensure that the rear of the CRS is in contact with the seat back by pressing the CRS backwards against the seat and making sure that the fore/aft markings are still aligned.
- (6) Where the rear head restraints interfere with the CRS, they shall be repositioned as necessary to avoid this. They may be removed if instructed to do so in the vehicle handbook.

#### 3.8.2.4.4.3 Q6 Dummy Positioning

- (1) Ensure that the dummy's upper back is in contact with the vehicle seat back if seated on a booster cushion or the back of the CRS if seated in a booster seat. This is done by bending the dummy's back into an upright position and then rocking the dummy sideways while at the same time pushing the pelvis backwards.
- (2) Ensure that the CRS is aligned with the new reference marks.
- (3) Ensure that the dummy is sat on the centreline of the CRS and is not rotated about the vertical axis.
- (4) Push the dummy's shoulders toward the seat back or CRS until either the shoulders contact the seat back or the booster seat back.
- (5) Ensure that the dummy is sitting in an upright position and is aligned with the centreline marks on the head restraint (if applicable) or is parallel to the marks of the centreline.
- (6) Ensure that the CRS position did not change relative to the marked position.

#### 3.8.2.4.4.4 Legs

- (1) Position the femurs straight forward with a distance of 150mm  $\pm$ 5mm between the centres of the knees. If the CRS prevents this gap from being achieved, position the knees as close to the target values as possible.
- (2) Where possible, allow the lower legs to rest naturally. The tibias shall be parallel to the vehicle centreline and the feet shall be separated by the same distance as the knees.

#### 3.8.2.4.4.5 Position of the Front Seat

Follow the steps detailed in Section 3.8.2.4.3.6 to establish whether or not the vehicle is considered to be of limited rear space for the Q6 see Section 3.8.2.5. If this is not the case, proceed with the steps below.

#### 3.8.2.4.4.6 Belt Routing

- (1) Ensure that the lap belt is routed through the belt guidance of the booster seat.
- (2) Remove the slack of the lap belt by pulling on the diagonal belt near the

buckle with a force of 150N.

- (3) Route the diagonal belt through the belt guidance of the booster for boosters with high back. Ensure that the belt is not twisted in the guidance of the booster.
- (4) The belt shall lie naturally across the chest and be allowed to sit as it falls. A load of 50N shall be applied to the diagonal section of the belt towards the D-loop to achieve a natural and flat belt position across the chest.
- (5) The use of any non-permanent belt guides or clips on either the vehicle or CRS is prohibited.
- (6) There shall be no tape or stickers applied to the diagonal section of the adult belt.

#### 3.8.2.4.4.7 Arms

- (1) The upper arm shall be positioned parallel to the chest. The measurements shall be taken on the neoprene suit along the front surface of the arm (bicep) and along the IR-TRACCs on the chest.
- (2) Position the lower arms parallel to the upper legs resting on the booster or armrest as close as possible to the side of the femur. The elbows shall be kept as close as possible to the torso.

#### 3.8.2.5 Vehicles with Limited Rear Space

Vehicles will be considered as having limited rear space when the child dummies cannot be installed with the front seats in the full-scale impact test position after adjustment in Section 3.8.2.4.3.6. Where this is the case, the technical service will confirm that child dummy cannot be installed without interference from the vehicle.

Where a manufacturer wishes to avoid being awarded zero points for the CRS dynamic assessments, the dynamic performance will be based on manufacturer's data from test(s) with modified front seating positions. These tests shall be performed using the appropriate CRS with the front seats positioned to one notch forwards of contact with the dummy. The dummy pelvis shall be positioned in the last step in after adjustment in Section 3.8.2.4.3.6.

In order to reduce the test burden, it may be possible to install both of the child dummies in the official frontal ODB impact as the driver and passengers seat are more forward than in the side MDB test. Where this is the case, the official ODB test will be performed as normal and the manufacturer need only provide in house data from an equivalent side impact. Any of the front or side MDB tests must be performed with both child dummies present to evaluate occupant interaction.

The tests must be equivalent to the Euro NCAP front and side impact tests and contain an equivalent level of instrumentation. Adult dummies are not required but

their mass shall be compensated for in the final test mass. It is the responsibility of the vehicle manufacturer to ensure that adequate film coverage of the impact, and specifically child head excursion and head containment, is provided.

See Section 2.2.4.2 of the COP Assessment protocol for further details.

If the technical service has established that the vehicle is not able to accommodate the Q10 dummy seated on a booster cushion due to interaction between the dummy head and vehicle roof, the Q10 will be seated directly on the rear seat without the use of any booster cushion. If, with the Q10 seated directly on the rear seat, there is still insufficient space between the dummy head and vehicle roof, the vehicle will be assessed in the same way as a two seater.

### 3.8.3 Angle Measuring Device

A 9kg articulated steel device used to measure the angle between the seat and the backrest. Extract taken from pr EN1888:2012: Child care articles - Wheeled child conveyances – Safety requirements and test methods.

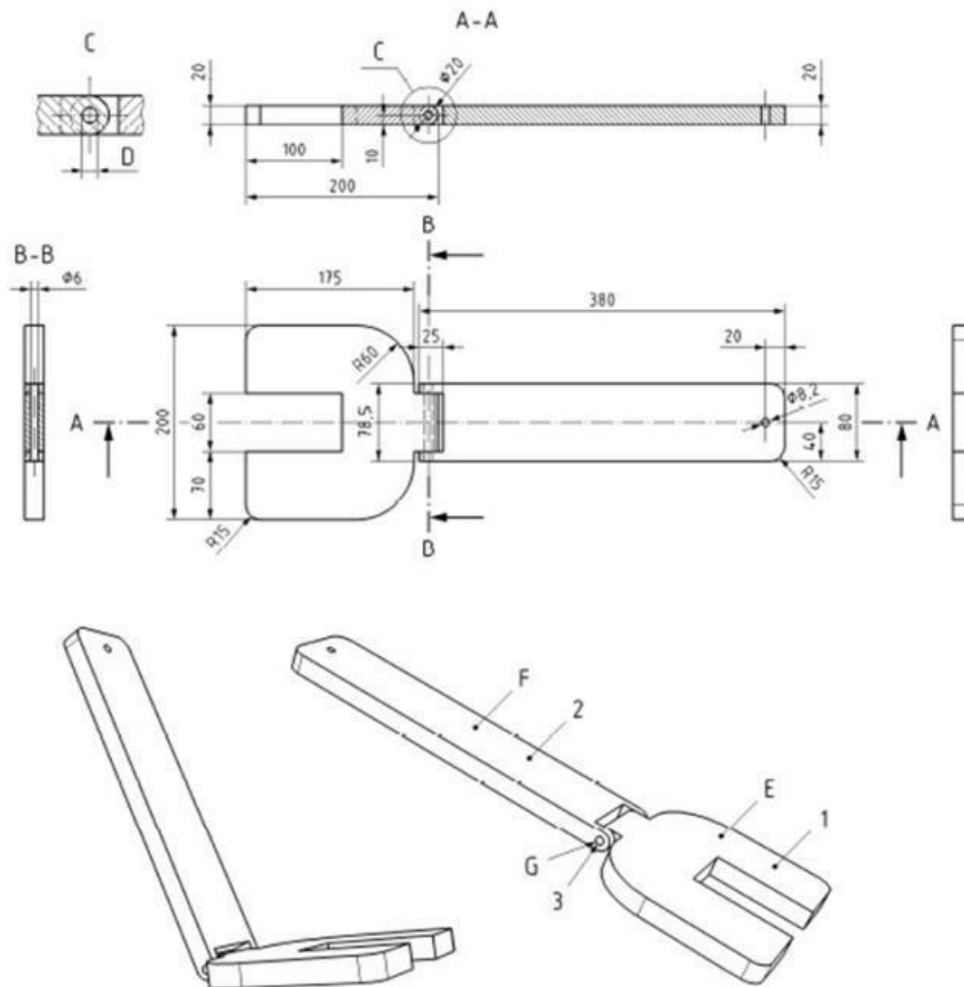

Notes:

- 1: part to be placed onto the seat surface made of steel
- 2: part to be placed onto the backrest surface made of steel
- 3: hinge pin made of steel



E mass:  $4495 \pm 50$  g

F mass:  $4501 \pm 50$  g

G mass of hinge axle:  $17 \pm 0.5$  g, length: 79.5 mm.

Total mass tolerance:  $(9 \pm 0.1)$  kg, dimensions tolerance:  $\pm 2$ mm

All edges shall be chamfered