

**Ministry of Transportation and  
Communications**

**Taiwan New Car Assessment Program  
(TNCAP)**

**Second Version**

**3.9 Pedestrian Testing Protocol**

V2.1  
Apr 2025

## TABLE OF CONTENTS

3.9.1 Vehicle Preparation .....	3
3.9.2 Assessment of Vehicles with Deployable Systems .....	4
3.9.3 Vehicle Marking.....	15
3.9.4 Headform DATA .....	34
3.9.5 Headform Verification Tests .....	36
3.9.6 Determination of Upper Legform and Legform Impact Points .....	38
3.9.7 Recording the Impact Point Locations.....	40
3.9.8 Performing of Pedestrian Impact Tests .....	41
3.9.9 Legform Tests .....	43
3.9.10 Upper Legform to Bumper Tests .....	48
3.9.11 Upper Legform to WAD775mm Tests .....	50
3.9.12 Headform Testing.....	53
3.9.13 Glossary of Terms .....	56

### 3.9.1 Vehicle Preparation

#### 3.9.1.1 Unladen Kerb Weight

- 3.9.1.1.1 The capacity of the fuel tank will be specified in the manufacturer's booklet. This volume will be referred to throughout as the 'fuel tank capacity'.
- 3.9.1.1.2 Syphon most of the fuel from the tank and then run the car until it has run out of fuel.
- 3.9.1.1.3 Refill the fuel tank with fuel (or an equivalent mass of water or other ballast) to its fuel tank capacity.
- 3.9.1.1.4 Check the oil level and top up to its maximum level if necessary. Similarly, top up the levels of all other fluids to their maximum levels if necessary.
- 3.9.1.1.5 Ensure that the vehicle has its spare wheel on board along with any tools supplied with the vehicle. Nothing else shall be in the vehicle.
- 3.9.1.1.6 Ensure that all tires are inflated according to the manufacturer's instructions for half load.
- 3.9.1.1.7 Remove the front vehicle license plate and its holder/brackets if these are removable from the bumper.
- 3.9.1.1.8 Measure the front and rear axle weights and determine the total weight of the vehicle. The total weight is the 'unladen kerb weight' of the vehicle. Record this weight in the test details.

#### 3.9.1.2 Additional Weights

- 3.9.1.2.1 Put the fore-aft adjustment of both front seats in their mid-positions. If there is no notch at the mid-position, use the first notch immediately rearward.
- 3.9.1.2.2 Place a 75kg mass on the driver's seat and a 75kg mass on the front passenger's seat.
- 3.9.1.2.3 Ensure that the front wheels are in the straight ahead position.
- 3.9.1.2.4 If the suspension is adjustable in any way, ensure that the vehicle is at the correct attitude for travelling at 40km/h. See Section 3.9.1.4.

#### 3.9.1.3 Suspension Settling

- 3.9.1.3.1 Roll the vehicle forwards by a distance of at least 1 meter
- 3.9.1.3.2 Roll the vehicle backwards by a distance of at least 1 meter
- 3.9.1.3.3 Repeat steps 3.9.1.3.1 and 3.9.1.3.2 for three complete cycles. Note: This procedure may be inappropriate for cars which have to be set up as described in Section 3.9.1.2.4.
- 3.9.1.3.4 Measure and record the ride heights of the vehicle at the point on the wheel arch in the same transverse plane as the wheel centres. Do this for

all four wheels.

#### 3.9.1.4 Normal Ride Attitude

3.9.1.4.1 After following the above procedures the vehicle is in its Normal Ride Attitude when the vehicle attitude is in running order positioned on the ground, with the tires inflated to the recommended pressures, the front wheels in the straight-ahead position, with maximum capacity of all fluids necessary for operation of the vehicle, with all standard equipment as provided by the vehicle manufacturer, with a 75kg mass placed on the driver's seat and with a 75kg mass placed on the front passenger's seat, and with the suspension set for a driving speed of 40km/h in normal running conditions specified by the manufacturer (especially for vehicles with an active suspension or a device for automatic levelling).

3.9.1.4.2 The manufacturer shall specify the Normal Ride Attitude with reference to the vertical (Z) position of any marks, holes, surfaces and identification signs on the vehicle body, above the ground. These marks shall be selected such as to be able to easily check the vehicle front and rear ride heights and vehicle attitude. If the reference marks are found to be within  $\pm 25$ mm of the design position in the vertical (Z) axis, then the design position shall be considered to be the normal ride height. If this condition is met, either the vehicle shall be adjusted to the design position, or all further measurements shall be adjusted, and tests performed, to simulate the vehicle being at the design position. Where this is not the case, the normal ride height as determined within Section 3.9.1.3 will be used.

3.9.1.4.3 All ride heights measured are the Normal Ride Attitude ride heights.

#### 3.9.2 Assessment of Vehicles with Deployable Systems

##### 3.9.2.1 Prerequisites to Assessment

3.9.2.1.1 Prior to the testing and assessment of a vehicle equipped with a deployable system, the vehicle manufacturer must liaise with the TNCAP executive agency and technical service. This shall begin several weeks before the scheduled test date.

3.9.2.1.2 In order for systems to be assessed in the deployed position or for the system to be deployed during the tests, it will be necessary for the vehicle manufacturer to provide the TNCAP executive agency with the relevant detailed information highlighted in the following sections before any testing begins.

3.9.2.1.3 The vehicle manufacturer is responsible for providing all necessary information, detailed in this protocol, to the TNCAP executive agency

regarding detection of pedestrians and the deployment of the system. Based on the evidence provided, the executive body will decide whether or not the vehicle qualifies for assessment in either the deployed or undeployed position or if dynamic tests are required.

3.9.2.1.4 General information is also required regarding the functionality of the system along with specific details of the sensing, trigger and deployment systems.

3.9.2.1.5 The vehicle manufacturer must ensure that the technical service is given adequate information regarding the replacement of consumable components, system trigger requirements, details of any health hazards and sufficient spare parts to ensure that testing can be performed on schedule.

3.9.2.1.6 Where there is no information, a lack of sufficient information or the system does not meet the TNCAP requirements; the vehicle will be assessed without triggering of the active pedestrian protection elements.

3.9.2.1.7 The moveable bonnet top is defined as all structures connected to the bonnet that move with the whole assembly when activated in a pedestrian impact. The rear edge of the bonnet is the most rearward point of the moveable bonnet top when it is closed.

### 3.9.2.2 Detection of Pedestrians

3.9.2.2.1 PDI2 is the default test tool to be used when demonstrating system triggering for the hardest to detect (HTD) pedestrian. Where PDI2 has been used, it will not be necessary for CAE data to be provided justifying the HTD as detailed in 3.9.2.2.2. However, head impact times and physical testing will still be required as in 3.9.2.2.3 along with the total response time (TRT) of the system.  $TRT = \text{sensing time (ST)} + \text{deployment time (DT)}$ .

3.9.2.2.2 Where the vehicle manufacturer believes that the PDI2 is not an appropriate test tool for replicating the HTD pedestrian, they must demonstrate with an alternative tool the sensor system's ability to detect a range of pedestrian statures that result in head contacts with the vehicle. The statures shall be selected from a 6 year old child, 5th percentile female, 50th percentile male and 95th percentile male. A combination of physical testing and numerical simulations will be required to demonstrate the suitability of the sensing system for the range of pedestrian sizes.

3.9.2.2.2.1 The numerical simulations will be required to identify the 'hardest to detect' (HTD) pedestrian and support the use of an alternative test

tool. The simulations, which must also include the PDI2 responses, will concern the pedestrian statures that result in head contact with the bonnet, as studied and proven in Section 3.9.2.3. Head impact times, according to the definitions from Euro NCAP Technical Bulletin TB 024 Version 1.1, must be provided for all statures regardless of where they contact the vehicle along with the total response time (TRT) of the system.  $TRT = \text{sensing time (ST)} + \text{deployment time (DT)}$ .

- 3.9.2.2.2.2 A minimum of two numerical simulations per appropriate stature (maximum 8 in total) will be required to identify the ‘hardest to detect’ pedestrian and support the choice of test tool. Pedestrian models shall be selected from the different statures specified in Section 3.9.2.2.2.
- 3.9.2.2.2.3 The procedure to certify pedestrian models and the simulation setup is detailed in Euro NCAP Technical Bulletin TB 024 Version 1.1.
- 3.9.2.2.2.4 No changes to the pedestrian model, control cards or control settings are allowed after the certification.
- 3.9.2.2.2.5 The pedestrian stance to be used in the model will be facing in a direction perpendicular to the vehicle centerline with the legs apart walking towards the vehicle centerline with the rearward leg being impacted by the bumper first. The same simulation shall be used even if the curvature of the bumper results in the front leg being impacted first.
- 3.9.2.2.2.6 The detailed initial posture of the pedestrian is described in Euro NCAP Technical Bulletin TB 024 Version 1.1. The posture of the pedestrian must not be changed between certification and assessment simulations.
- 3.9.2.2.2.7 The contact settings must be consistent with those used in the certification simulations according to Euro NCAP TB 024 Version 1.1. The frictional value to be applied between the foot and the ground shall be 0.3.
- 3.9.2.2.2.8 Simulations shall be conducted at the system’s lower deployment threshold (LT) impact speed specified by the vehicle manufacturer.
- 3.9.2.2.2.9 The simulations will be conducted at two separate locations on the bumper. For each of the appropriate statures simulations will be performed on the vehicle centreline and at the outboard end of the bumper test zone defined in Section 3.8.8. An additional simulation may be required where the bumper test zone is relatively narrow when compared to the width of the moveable bonnet top.
- 3.9.2.2.2.10 Outputs from the simulations shall clearly highlight what the

critical pedestrian size is for that particular sensing system. Once the hardest to detect pedestrian is established the appropriate test tool that reflects the characteristics of that pedestrian can be identified for use in the physical tests. The minimum output parameters from the numerical simulations will be:

- (1) Bumper force
- (2) Effective mass
- (3) Energy
- (4) Bumper intrusion
- (5) Acceleration (when used as trigger)

3.9.2.2.2.11 Effective mass will be calculated as follows. This calculation assumes that peak force on the vehicle occurs when the leg velocity reaches 0m/s:

$$M_e = \frac{\int_{t_1}^{t_2} F dt}{\Delta v}$$

- Me = Effective mass (kg)
- F = Force (N)
- Δ v = Change in velocity (m/s)
- dt = Time increment (s)
- t<sub>1</sub> = Time of first contact (s)
- t<sub>2</sub> = Time of peak force (s)

3.9.2.2.2.12 In the event that a system triggers before the peak force is imparted onto the bumper cross member, the following calculation shall be use:

$$M_e = \frac{\int_{t_1}^{t_2} F dt}{\int_{t_1}^{t_2} a dt}$$

- Me = Effective mass (kg)
- F = Force (N)
- a = Leg acceleration (m/s<sup>2</sup>)
- dt = Time increment (s)
- t<sub>1</sub> = Time of first contact (s)
- t<sub>2</sub> = Time of system trigger (s)

3.9.2.2.2.13 For the calculation of effective mass, only movement in the X direction is considered. The most significant structures that load the leg shall be considered, such as the bumper cross member and any upper or lower cross beams. Less significant structures, such as grills and valances may be ignored. Viscous effects shall be ignored.

3.9.2.2.2.14 For the outputs specified in Section 2.2.2.10, the most appropriate trigger parameter(s) for the specific type of sensing system will be used to show an appropriate level of correlation between the chosen test tool and the numerical simulations. Trigger parameters must correspond with the system sensing time. The vehicle manufacturer may choose the impact location and vehicle components for inclusion

onto the calculation of the output parameters.

3.9.2.2.3 Physical testing is employed to evaluate the performance of the sensing system(s). To simulate a pedestrian larger or heavier than a 50th percentile male, the legform described in Section 3.9.9 for legform-to-bumper tests shall be employed. This ensures that the system deploys appropriately when encountering larger or "upper limit" pedestrians.

3.9.2.2.3.1 To ensure that the pedestrian impact sensor(s) are effective across the full bumper width, a minimum of three tests shall be performed at locations within the bumper test zone.

3.9.2.2.3.2 Test Matrix

Test	Impactor	Impact Point	Speed	Output
1	PDI2/ HTD <sup>(1)</sup>	<ul style="list-style-type: none"> <li>•Directly on localized sensor e.g. accelerometer +/-50mm. If the sensing system uses a combination of contact strip switches and localized accelerometers, the positions of the accelerometers shall be used to define the impact locations.</li> <li>•For non-localized sensor systems, such as contact switches, test the vehicle centerline.</li> </ul>	LT <sup>(2)</sup> +/-2km/h	
2	PDI2/ HTD	Bumper test zone end, left or right-hand side, +/-50mm.	LT+/-2 km/h	•High speed film
3	PDI2/ HTD	Farthest from sensor(s) if not tested already, +/-50mm.	LT+/-2 km/h	•Actuator trigger
4 <sup>(3)</sup>	TNCAP detailed in Section 3.9.9.1 or WG17 impactor to account for larger pedestrians	Directly on localized sensor e.g. accelerometer, +/-50mm. For non-localized sensor systems test directly in line with the front longitudinal member to produce the highest acceleration levels on the impactor. This test may be performed using a representative surrogate with equivalent mass and stiffness to prevent damage to instrumentation.	40km/h +/- 2km/h	time •Initiation of deployment

Notes:

1. HTD = Other appropriate hardest to detect (as defined by section 3.9.2.2.2).
2. LT = Lower deployment Threshold.

3. The impactor for test 4 may be chosen by the vehicle manufacturer.

3.9.2.2.3.3 At least test #3 shall be witnessed or performed by TNCAP executive agency to verify deployment of the system at the lower threshold. Alternatively, it may be performed by the manufacturer in-house and witnessed by TNCAP executive agency. The cost of the above shall be borne by the assessed vehicle manufacturer.

3.9.2.2.3.4 Where a test is performed below the lower threshold speed but within the velocity tolerance or outside the bumper test zone and the system does not deploy, the test must be repeated at a speed no less than the lower threshold and not outside the bumper test zone.

3.9.2.2.3.5 The outputs from all physical tests shall include, but is not limited to:

- (1) Good quality high speed film showing an overview of the test.
- (2) Documentation of the correct test location, e.g. using paint marks and post test photographs.
- (3) Documentation of test speed (vehicle or impactor as applicable), e.g. using known road markings or speed measurement systems etc.
- (4) Actuator trigger time (current clamp/ECU).
- (5) Evidence of system deployment initiation, i.e. film showing the first movement of the bonnet top or frangible break wires/contacts/squibs.

3.9.2.2.3.6 The first physical test, or tests, must be performed with the pedestrian protection system fully functional from the sensing systems to the bonnet actuators/airbag squibs. At the same time, it is acceptable to include an additional means of highlighting deployment, such as flashes and/or squibs for that first test. Once a valid firing time and system deployment has been confirmed, the remaining tests may then be performed with the flashes/squibs connected in place of the bonnet actuators or airbag; thus negating the need for deployment. The entire system architecture shall be present up to the bonnet actuators/airbag for all tests. Flashing hazard warning lights or other indications that are not connected to the actuator wiring system will not be accepted.

### 3.9.2.3 Timing of System Deployment

3.9.2.3.1 Grid points that are not affected by the active system will be tested statically.

3.9.2.3.2 Where the manufacturer has demonstrated, by numerical simulations or

alternative means (vehicle speed of 45km/h), that a system is fully deployed and remains in the intended position prior to the head impact time of the smallest appropriate stature pedestrian, then all headform tests shall be performed with the bonnet in the fully deployed position. There will be no need to trigger any active elements during the sub system pedestrian tests. This does not apply to airbag systems.

3.9.2.3.3 However, where the system is not fully deployed before the HIT for any appropriate stature, all grid points forwards of the corresponding wrap around distance will be tested dynamically.

3.9.2.3.4 For systems that do not remain in a permanently deployed position then dynamic pedestrian testing will be required for all test locations.

3.9.2.3.5 The simulations shall be performed using the unchanged pedestrian model and simulation setting from Euro NCAP Technical Bulletin TB 024 Version 1.1. Numerical simulations shall be performed with the bonnet in the undeployed position with all pedestrian statures that result in head contact to the bonnet. Pedestrian models shall be selected from the following statures, a six year old, 5th percentile female, 50th percentile male and 95th percentile male. The pedestrian position and stance to be used in the model is defined in Euro NCAP Technical Bulletin TB 024 Version 1.1, positioning the pedestrian's head centre of gravity on the vehicle centreline.

3.9.2.3.6 From the simulation, the vehicle manufacturer must determine the wrap around distance for each test location and establish the relevant head impact time for that stature of pedestrian. A graph shall be plotted with a best fit straight line which also identifies the total response time (TRT) of the system as shown in Figure 1. The plot of wrap around distance vs head impact time shall be provided for the assessed vehicle fitted with a deployable system. The determination of HIT must be consistent with the definition from Euro NCAP Technical Bulletin TB 024 Version 1.1.

3.9.2.3.7 Further details on performing dynamic tests are provided in Section 3.9.8.5.

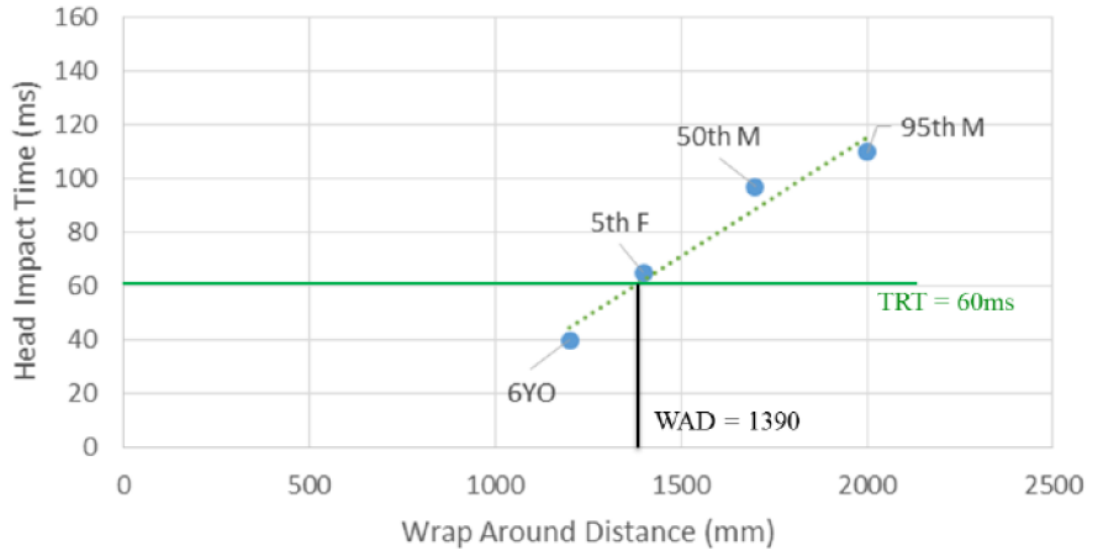

Figure 1: Wrap Around Distance (WAD) vs Head Impact Time (HIT)

### 3.9.2.4 Protection at Speeds below the Deployment Threshold

#### 3.9.2.4.1 Exemption Zones

3.9.2.4.1.1 TNCAP maintains that vehicles that offer protection without a deployable device, offer protection at lower speeds and some protection at higher speeds. Therefore, TNCAP requires that vehicles equipped with deployable pedestrian protection systems also provide protection at impact speeds below the system deployment threshold on the part of the vehicle affected by the deployable pedestrian protection system.

3.9.2.4.1.2 The area of the vehicle considered will be all grid points that have a distance measured in the lateral Y axis of 50mm or more inboard from the side reference lines and 50mm or less measured in the lateral Y axis outboard from the movable bonnet shut line. See Figure 2.

3.9.2.4.1.3 The area will also extend rearward from the 1000mm wrap around distance (WAD) up to the rear of the movable bonnet top defined in 2.1.7. Child/small adult headforms will apply to grid points from wrap around distances 1000mm to 1700mm WAD inclusive and adult headforms will apply to grid points rearward from 1700mm up to the rear of the movable bonnet top. See Figure 2.

3.9.2.4.1.4 Where parts of the movable bonnet are to be tested in the deployed position e.g. based on head impact time, and others are not, the area of consideration will include all grid points that are located between the rear of the movable bonnet top and 50 mm forward or less from the most forward part of the bonnet that will be tested in the deployed position. See Figure 2.

3.9.2.4.1.5 The vehicle manufacturer is required to provide the TNCAP executive agency HIC15 or color data showing that, at the lower deployment threshold speed, no grid point within the area mentioned above that is predicted green, yellow or orange at 40km/h shall produce HIC values above 1350 at the lower deployment threshold.

3.9.2.4.1.6 For no less than 2/3rds of the total number of grid points within the prescribed area, HIC values must not exceed 1000.

3.9.2.4.1.7 Data shall be provided for each grid point according to the following performance criteria:

HIC15 < 1000 = Yellow

1000 < HIC15 < 1350 = Orange

3.9.2.4.1.8 Up to three physical tests may be performed to verify the CAE data at just below the deployment threshold speed. These tests will be selected at random by the TNCAP executive agency and technical service.

3.9.2.4.1.9 Where any of the criteria in Section 3.9.2.4.1.5 to 3.9.2.4.1.7 are not met, then all pedestrian tests will be performed with the system in the undeployed position.

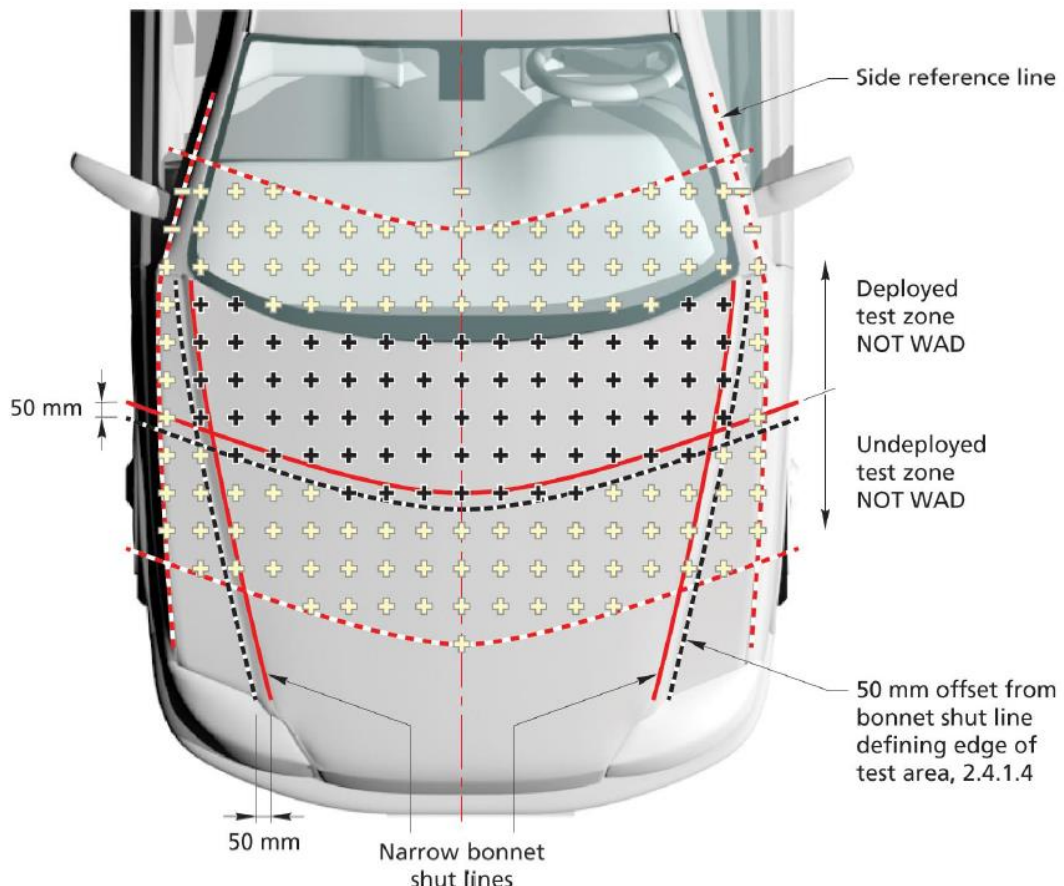

Figure 2: Area to meet low speed requirement

### 3.9.2.5 Protection at Higher Impact Speeds

#### 3.9.2.5.1 Upper deployment threshold

3.9.2.5.1.1 All deployable systems must initiate deployment at speeds of at least 50km/h. It is not necessary for a system to be fully deployed and reach the intended position before head impact at 50km/h, but the vehicle manufacturer must show that deployment has initiated.

3.9.2.5.1.2 A physical test using the impactor chosen in Section 3.9.2.2 is required at 50km/h to show that deployment has initiated. The outputs from the test are as those described in Section 3.9.2.2.3.5.

3.9.2.5.1.3 The test shall be performed at either the vehicle centreline or, if localized sensors used, as far away from the sensor as a possible while remaining within the bumper test zone.

### 3.9.2.6 Bonnet Deflection due to Body Loading

3.9.2.6.1 Given that deployable bonnets may have reduced support from their peripheral structures compared to passive systems, TNCAP requires that head protection is not compromised by bonnet collapse.

3.9.2.6.1.1 The evaluation shall be calculated with the use of CAE without the 'package' being present. The package meaning engine and ancillaries. All body in white structures and bonnet supports must be present. However, all components that load the legs and pelvis must be included.

3.9.2.6.1.2 This is done by measuring and comparing the Z displacement at the position of head contact for both a deployed and undeployed bonnet at the time of first head contact. At the position of head impact the difference between deployed and undeployed bonnet can be no more than 75% of the generated deployment height at that point, see Figure 3.

3.9.2.6.1.3 At the point of head impact it is essential that the bonnet deflection in the deployed state does not exceed the total available clearance between deployed bonnet and under bonnet hard point, i.e.  $(h_2 + h_3) - z_2 > 0$ , see Figure 4.

3.9.2.6.1.4 This would be established using numerical simulations at 40km/h with the appropriate sized pedestrian that loads the least supported part of the bonnet top for that particular size of vehicle. For example, on a small vehicle with a short bonnet it may be that the 50th percentile male contacts the vehicle rearward of the bonnet top. Therefore, a smaller pedestrian stature will be required.

3.9.2.6.1.5 The stance described in Euro NCAP Technical Bulletin TB 024

Version 1.1 shall be used positioning the pedestrian's head centre of gravity on the vehicle centreline. Unchanged certified pedestrian models and simulation settings must be applied.

1. Undeployed simulation: 40 km/h, centreline, walking posture, 50<sup>th</sup>% (if no bonnet contact 5<sup>th</sup>%)

All measures are taken vertically at head impact point at first time of head contact.

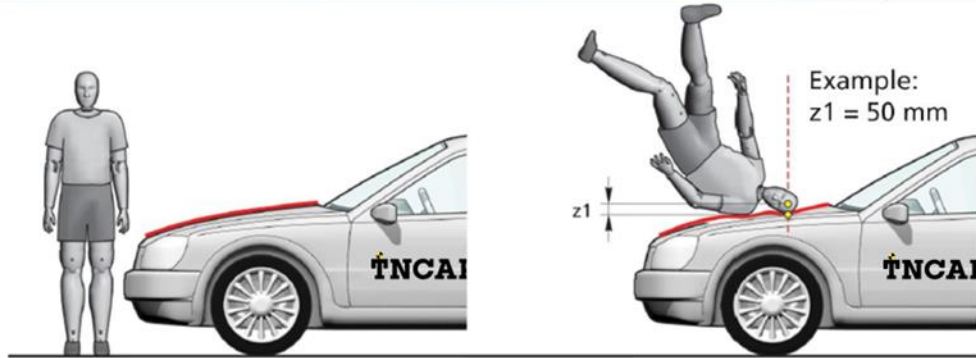

Output:  
a. Z displacement at head contact point: z1 at first time of head contact

2. Deployed simulation: 40 km/h, centreline, walking posture, 50<sup>th</sup>% (if no bonnet contact 5<sup>th</sup>%)

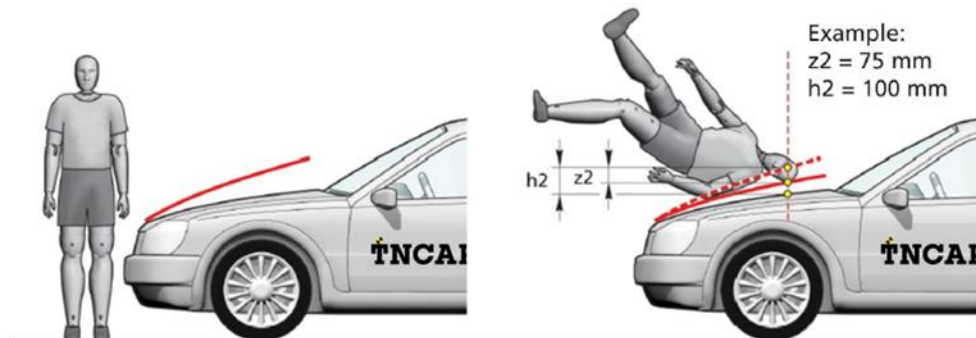

Output:  
b. Z displacement: z2  
c. Deployment height: h2

3. Requirement:

$$z2 - z1 < 75\% \times h2$$

Example:  
75 mm – 50 mm < 75% × 100 mm  
25 mm < 75 mm (= OK)

Bonnet deflection in the deployed state (z2) must not exceed bonnet deflection in the undeployed state (z1) by more than 75% of the deployment height (h2).

Figure 3: Bonnet deflection deployed and undeployed comparison

Simulation: 40 km/h, centreline, walking posture, 50<sup>th</sup>% (if no bonnet contact 5<sup>th</sup>%)

All measures are taken vertically at head impact point at first time of head contact.

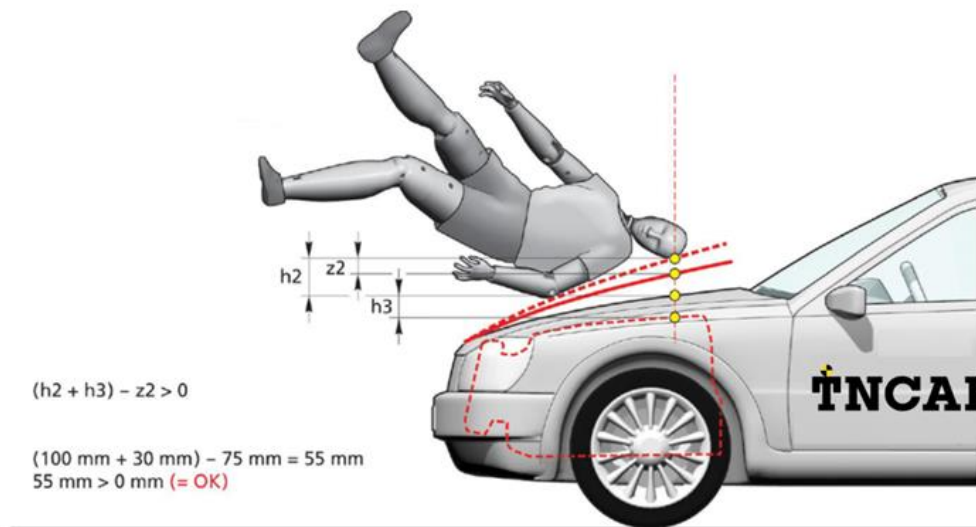

Figure 4: Bonnet deflection total clearance requirement

### 3.9.3 Vehicle Marking

#### 3.9.3.1 General

- 3.9.3.1.1 The vehicle shall be marked with a grid as described in the following sections. The marking procedures divide the front of the car into zones which are then assessed using appropriate impactors.
- 3.9.3.1.2 Where no predicted data is to be provided by the vehicle manufacturer, the testable area shall be marked as described in the Euro NCAP Pedestrian Testing Protocol version 5.3.1, November 2011.
- 3.9.3.1.3 All markings and measurements shall be made with the vehicle is in its Normal Ride Attitude.
- 3.9.3.1.4 The vehicle manufacturer must provide TNCAP with coordinates of all grid points derived from either CAE data or physical mark out.
- 3.9.3.1.5 A comparison of the grid origin C0,0 and two other points on WAD2100, will be made between the technical service mark out and the data provided by the vehicle manufacturer. For manufacturer predicted data to be accepted, grid points must be within 10mm of each other.
- 3.9.3.1.6 Where the grid points of TNCAP and vehicle manufacturer are within 10mm of each other the technical service mark-out shall be used.
- 3.9.3.1.7 Where the two grids differ by more than 10mm the vehicle manufacturer shall be informed and both markings will be examined in greater detail to establish the cause of any differences. The TNCAP executive agency will then take a decision as to how to proceed with vehicle marking.

- 3.9.3.1.8 The vehicle manufacturer must provide data for all headform grid locations. Testing will be carried out by TNCAP to a number of locations to verify the accuracy of data provided by the vehicle manufacturer.
- 3.9.3.1.9 For vehicles fitted with deployable systems, the headform impactor marking will be applied to the vehicle with the system in the undeployed state. This will be the case regardless of whether or not the bonnet is locking or non-locking or the vehicle uses an airbag.
- 3.9.3.1.10 For vehicles fitted with deployable systems, the WAD775mm and WAD930mm will be marked on the vehicle with the system in the undeployed state. If deployment occurs prior to the pedestrian contact with the WAD775mm, creating an increased hazard such as increased height, the TNCAP executive agency will give consideration to marking out the WAD775 and WAD930mm in the deployed state.
- 3.9.3.1.11 Where the vehicle manufacturer provides data showing that a deployable system offers protection to the upper leg, the upper legform tests will be carried out by conducting dynamic tests. The WAD775mm and WAD930mm will be marked on the vehicle in the deployed position.
- 3.9.3.1.12 In case of any gaps in the relevant markup areas of the vehicle front such as WAD 930 and the internal bumper reference line, e.g. in the grille area, approximate the outer contour of the vehicle using tape to span these gaps. Between the lower bumper reference line and the BLE, create a wrap around up to the BLE. All measurements and markings shall be placed on this tape. In case of any doubt how to place the tape use the WAD marking procedure, i.e. the covering tape is placed like the tape measure during WAD marking.

### 3.9.3.2 Bonnet Side Reference Line

The Bonnet Side Reference Line is defined as the geometric trace of the highest points of contact between a straight edge 700mm long and the side of a bonnet, as defined in Section 3.9.3.3.1 and A-Pillar, when the straight edge, held parallel to the lateral vertical plane of the car and inclined inwards by 45° is traversed down the side of the bonnet top and A-Pillar, while remaining in contact with the surface of the body shell, any contact with door mirrors is ignored. See Figure 5. Where multiple or continuous contacts occur the most outboard contact shall form the bonnet side reference line.

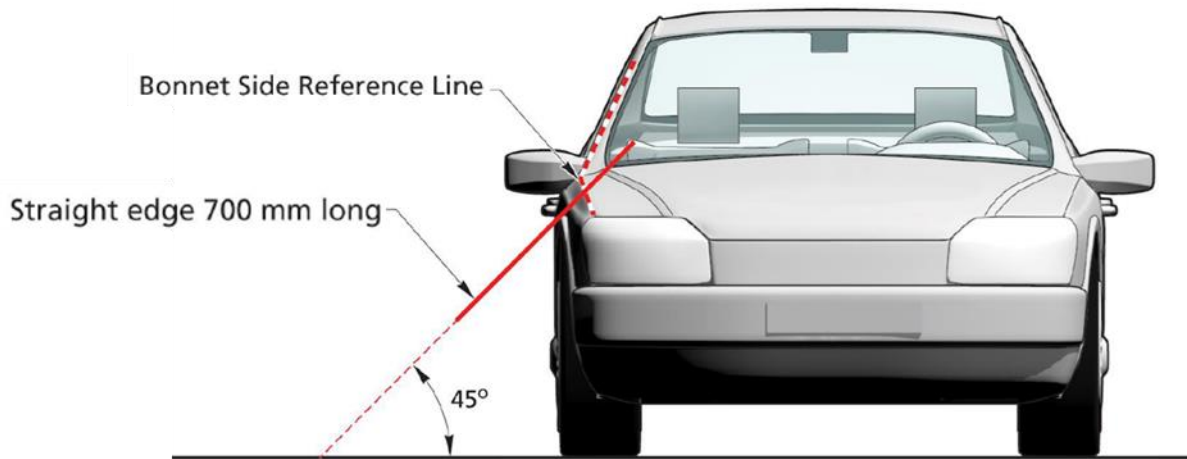

Figure 5: Determination of the bonnet side reference lines

- 3.9.3.2.1 Fix a straight edge that is 700mm long at  $45^\circ$  to the vertical. With this edge in a plane parallel to the lateral vertical plane of the car, position the straight edge at the front of the front wing and in contact with, the bonnet.
- 3.9.3.2.2 Mark the uppermost point of contact of the straight edge and wing.
- 3.9.3.2.3 Pull the straight edge away from the wing, move it towards the other end of the vehicle by not more than 100mm and then back into contact with the wing.
- 3.9.3.2.4 Mark the uppermost point of contact of the straight edge and wing.
- 3.9.3.2.5 Repeat Sections 3.9.3.2.3 to 3.9.3.2.4 moving the edge along the length of the wing, A-Pillar and Cant Rail if required (depending on the anticipated position of the WAD2100).
- 3.9.3.2.6 Using a flexible rule, join the marks on the vehicle to form a line. This line may not be continuous but may ‘jump’ around the wing/wheel arch.
- 3.9.3.2.7 Repeat for the other side of the vehicle.
- 3.9.3.2.8 A partial modification of the side reference lines may be necessary subsequent to the determination of the corner reference points according to Section 3.9.3.6.2.

### 3.9.3.3 Bonnet Leading Edge Reference Line

The Bonnet Leading Edge Reference Line is defined as the geometric trace of the points of contact between a straight edge 1000mm long and the front surface of the bonnet, when the straight edge, held parallel to the vertical longitudinal plane of the car and inclined rearwards by  $50^\circ$  and with the lower end 600mm above the ground, is traversed across and in contact with the bonnet leading edge, see Figure 6. For vehicles having the bonnet top surface inclined at essentially  $50^\circ$ , so that the straight edge makes a continuous contact or multiple contacts rather than a

point contact, determine the reference line with the straight edge inclined rearwards at an angle of  $40^\circ$ . For vehicles of such shape that the bottom end of the straight edge makes first contact then that contact is taken to be the bonnet leading edge reference line, at that lateral position. For vehicles of such shape that the top end of the straight edge makes first contact then the geometric trace of 1000mm wrap around distance will be used as the Bonnet Leading Edge reference line at that lateral position. The top edge of the bumper shall also be regarded as the bonnet leading edge, if it is contacted by the straight edge during this procedure.

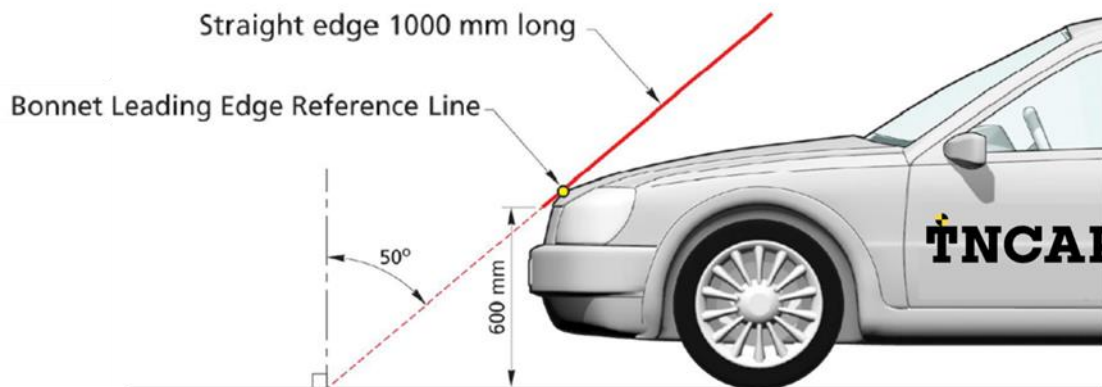

Figure 6: Determination of the Bonnet Leading Edge Reference Line

- 3.9.3.3.1 The bonnet leading edge is defined as the front upper outer structure including the bonnet and wings, the upper side members of the headlight surround and any other attachments.
- 3.9.3.3.2 Fix a straight edge that is 1000mm long at  $50^\circ$  to the vertical and with its lower end at a height of 600mm. If the top surface of the bonnet is inclined at essentially  $50^\circ$  so that the straight edge makes a continuous contact or multiple contacts rather than a point contact, determine the reference line with the straight edge inclined rearwards at an angle of  $40^\circ$ . With this edge in a plane parallel to the vertical longitudinal plane of the car, position the straight edge at one end of, and in contact with, the bonnet.
- 3.9.3.3.3 Mark the point of contact of the straight edge and bonnet.
- 3.9.3.3.4 If the bottom end of the straight edge makes first contact then mark this point of contact.
- 3.9.3.3.5 If the top end of the straight edge makes first contact behind the 1000mm Wrap Around Distance, then use the geometric trace of the 1000mm Wrap Around Distance at that lateral position.
- 3.9.3.3.6 Pull the straight edge away from the bonnet, move it towards the other end of the bonnet by not more than 100mm and then into contact with the bonnet.

- 3.9.3.3.7 Mark the point of contact of the straight edge and bonnet.
- 3.9.3.3.8 Repeat Sections 3.9.3.3.4 to 3.9.3.3.7 across the whole width of the bonnet. Using a flexible rule, join the marks on the bonnet to form a line. This line may not be continuous but may ‘jump’ around the grill and badge area etc. This line is the Bonnet Leading Edge Reference Line.

#### 3.9.3.4 Bonnet Rear Reference Line

The Bonnet rear reference line is defined as the geometric trace of the most rearward point of contact between a 165mm sphere and the frontal upper surface, when the sphere is traversed across the frontal upper surface, while maintaining contact with the windscreen.

- 3.9.3.4.1 Remove the wiper blades and arms.
- 3.9.3.4.2 Place a 165mm sphere at the vehicle centreline on the frontal upper surface so that the rearmost point of contact of the sphere is always on the glass.
- 3.9.3.4.3 Mark the most forward point of contact between the sphere and the vehicle’s frontal upper surface. Repeat this at suitable increments moving outboard until the sphere contacts the side reference line on both sides of the vehicle. See Figure 7.

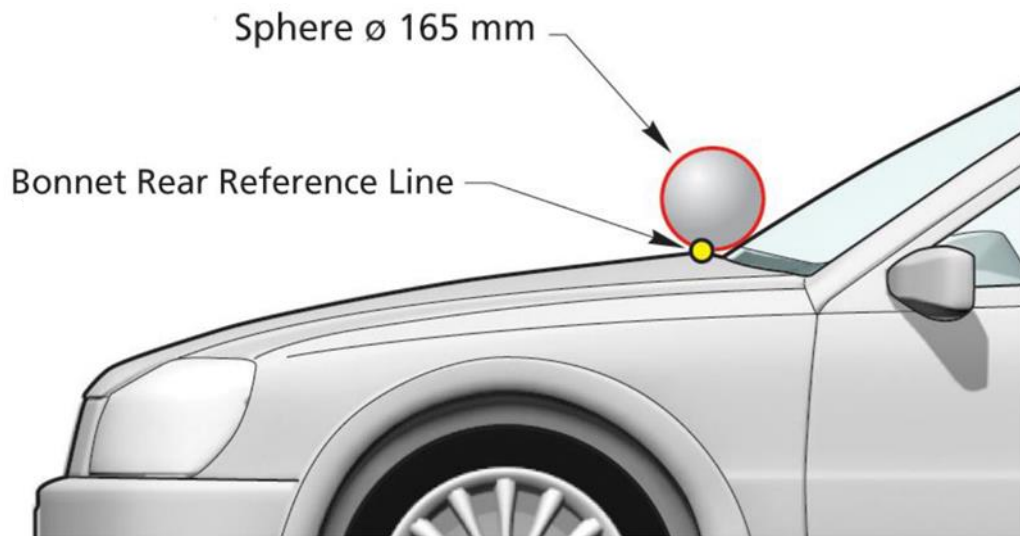

Figure 7: Determination of the bonnet rear reference line

- 3.9.3.4.4 If the bonnet rear reference line is located at a wrap around distance of more than 2100mm, the bonnet rear reference line is defined by the geometric trace of the 2100mm wrap around distance.
- 3.9.3.4.5 Where the bonnet rear reference line and side reference line do not intersect, the bonnet rear reference line is extended and/or modified using a semi-circular template, of radius 100mm. The template shall be made of a thin flexible sheet material that easily bends to a single

curvature in any direction. The template shall, if possible, resist double or complex curvature where this could result in wrinkling. The recommended material is a foam backed thin plastic sheet to allow the template to ‘grip’ the surface of the vehicle.

3.9.3.4.6 The template shall be marked up with four points ‘A’ through ‘D’, as shown in Figure 8, while the template is on a flat surface. The template shall be placed on the vehicle with Corners ‘A’ and ‘B’ coincident with the side reference line. Ensuring these two corners remain coincident with the side reference line, the template shall be slid progressively rearwards until the arc of the template makes first contact with the bonnet rear reference line. Throughout the process, the template shall be curved to follow, as closely as possible, the outer contour of the vehicle’s bonnet top, without wrinkling or folding of the template. If the contact between the template and bonnet rear reference line is tangential and the point of tangency lies outside the arc scribed by points ‘C’ and ‘D’, then the bonnet rear reference line is extended and/or modified to follow the circumferential arc of the template to meet the side reference line, as shown in Figure 8.

3.9.3.4.7 If the template does not make simultaneous contact with the side reference line at points ‘A’ and ‘B’ and tangentially with the bonnet rear reference line, or the point at which the bonnet rear reference line and template touch lies within the arc scribed by points ‘C’ and ‘D’, then additional templates shall be used where the radii are increased progressively in increments of 20mm, until all the above criteria are met.

3.9.3.4.8 Once defined, the modified bonnet rear reference line is assumed in all subsequent paragraphs and the original ends of the line are no longer used.

3.9.3.4.9 Replace the wiper arms and blades.

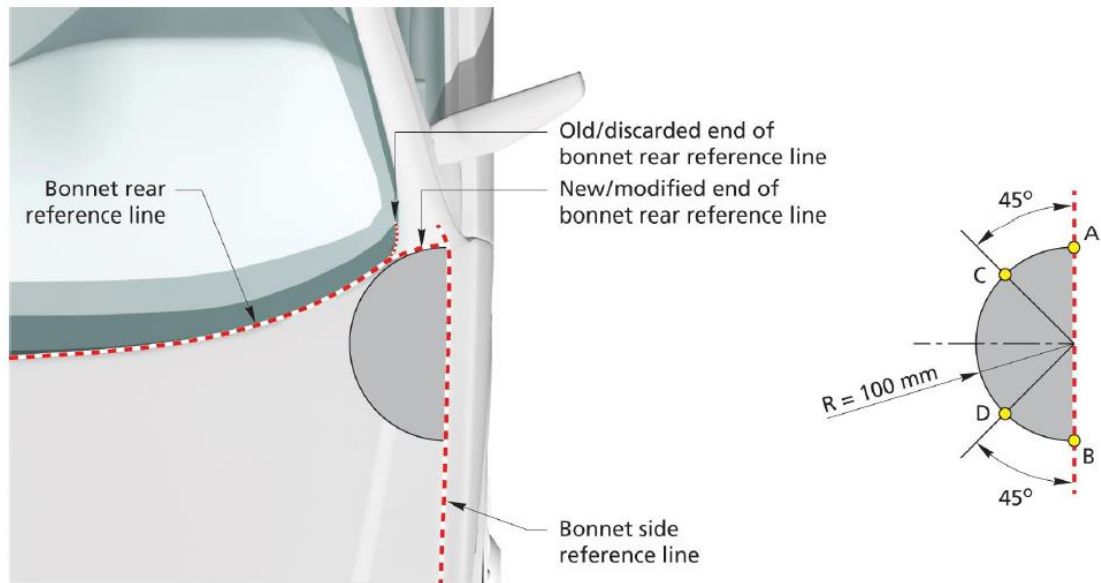

Figure 8: Bonnet rear reference line template and extension

### 3.9.3.5 Marking Wrap Around Distances (WAD)

The headform test area is defined as the outer structure that includes the upper surface of all outer structures. It includes, but is not limited to, the bonnet, wings, windscreen scuttle, wiper arms/spindles, windscreen frame, A-pillars and roof. It is bounded by the geometric trace of the 1000mm wrap around line in the front, the Bonnet Side Reference Lines and the 2100mm wrap around distance (WAD).

3.9.3.5.1 Begin at the vehicle centerline.

3.9.3.5.2 Place the end of a flexible tape measure or graduated wire on the floor vertically below the front face of the bumper.

3.9.3.5.3 Wrap the tape or wire over the bumper, bonnet windscreen and roof ensuring that it is maintained in a vertical longitudinal (X, Z) plane and that its end is still in contact with the ground. The tape shall be held taut throughout the operation, vertically below the front face of the bumper, see Figure 9.

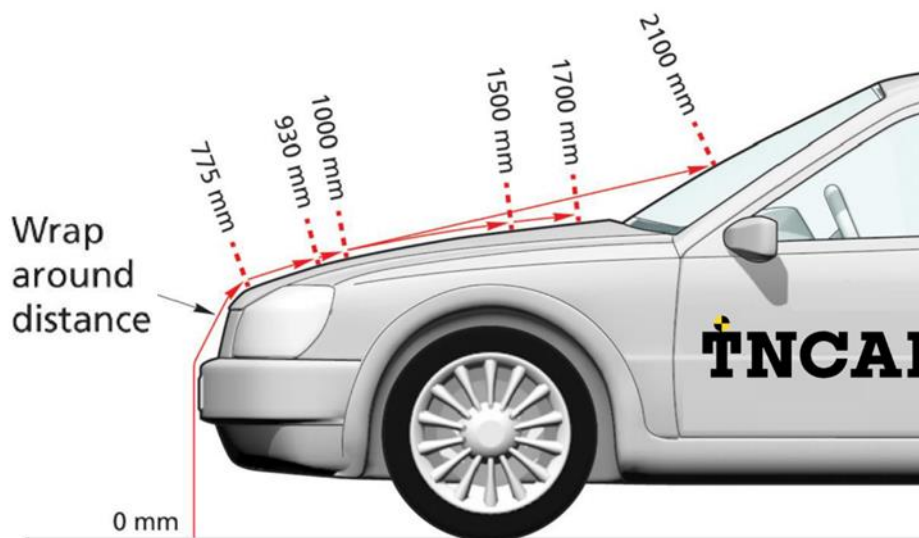

Figure 9: Marking wrap around lines

- 3.9.3.5.4 Mark on the bumper/grille, bonnet top, windscreen, A-pillars and/or roof the wrap around distances of 775mm, 930mm, 1000mm, 1500mm, 1700mm and 2100mm. These are the geometric traces described on the outer surface of the vehicle by the end of flexible tape or wire 775mm, 930mm, 1000mm, 1500mm, 1700mm or 2100mm long, when it is held in a vertical fore/aft plane of the car and traversed across the front of the bonnet and bumper.
- 3.9.3.5.5 Where any of the WAD's lie below the outer contour of the vehicle, for example in the gap behind the bonnet, using the tape or wire approximate the outer contour of the vehicle horizontally rearward from the last point of contact and project the WAD vertically down onto the underlying structure.
- 3.9.3.5.6 Reposition the end of the tape on the ground no further than 100mm laterally outboard starting at the vehicle centreline up to the Corner of Bumper. The tape shall be stretched over the A-pillars where necessary.
- 3.9.3.5.7 Repeat steps 3.9.3.5.2 to 3.9.3.5.6 until the width of the vehicle has been marked up to the Side Reference Lines.
- 3.9.3.5.8 Join the points marked on the bonnet to form lines at wrap around distances of 775mm, 930mm, 1000mm, 1500mm, 1700mm and 2100mm. Points located from 1000mm to 1500mm WAD inclusive will be assessed using the child/small adult headform. Points from 1700mm to 2100 mm WAD inclusive will be assessed with the adult headform, see Figure 10.
- 3.9.3.5.9 Where the bonnet rear reference line is between 1500mm and 1700mm

WAD, points forward of and directly on the bonnet rear reference line will be assessed using the child/small adult impactor. Where the BRRL is rearward of 1700mm WAD, the child/small adult headform shall be used up to and including 1700mm. Points rearward of the bonnet rear reference line between 1500mm and 1700mm WAD will use the adult impactor.

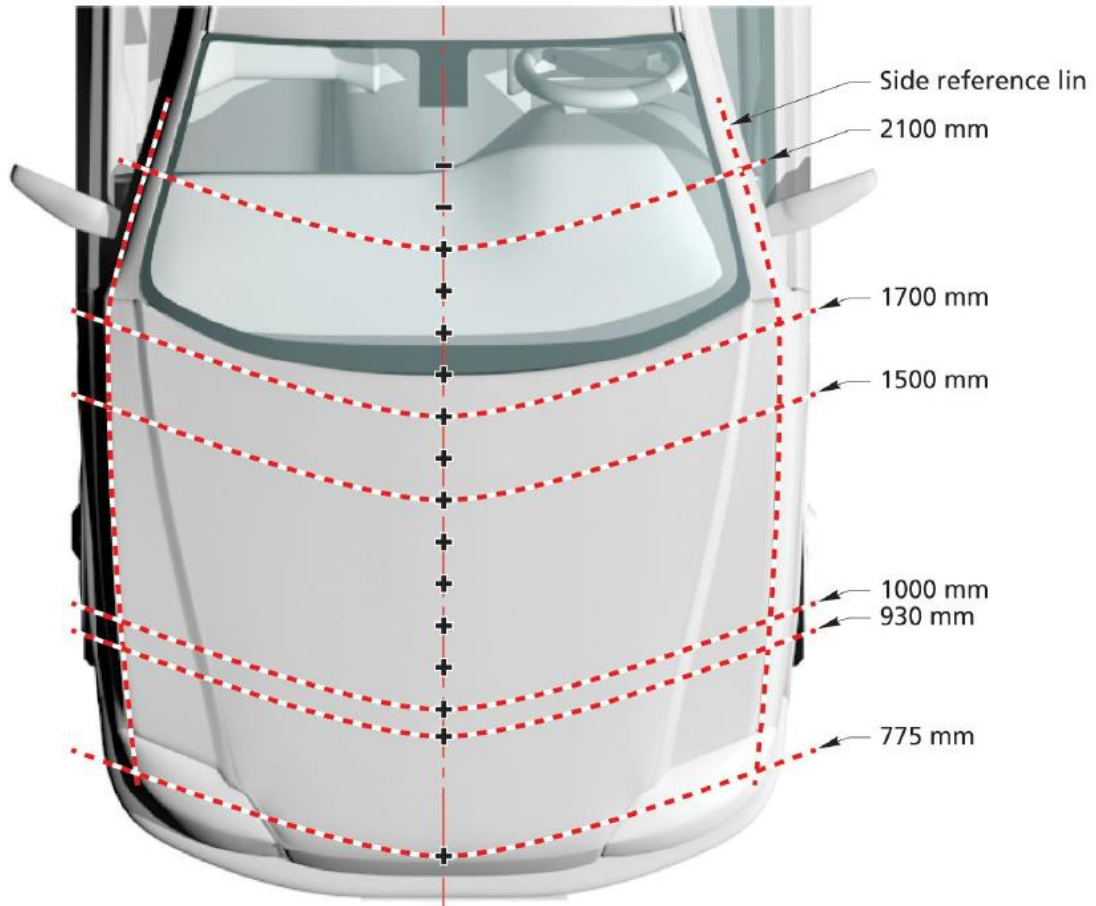

Figure 10: Headform test area

### 3.9.3.6 Corner Reference Point

The Corner Reference Point is defined as the intersection of the Bonnet Leading Edge reference line (Section 3.9.3.3) and the Bonnet Side reference line (Section 3.9.3.2), see Figure 11. Where multiple or continuous contacts occur the most outboard contact shall form the corner reference point.

3.9.3.6.1 The corner reference point shall be transferred forwards onto the WAD775mm at the same distance from the vehicle centreline.

3.9.3.6.2 In case of the corner reference point being located rearwards the WAD 1000 mm, a line connecting the corner reference point and its forward projection onto the WAD 1000 mm at the same distance from the vehicle centerline shall replace the section of the side reference line which is

located forwards the corner reference point.

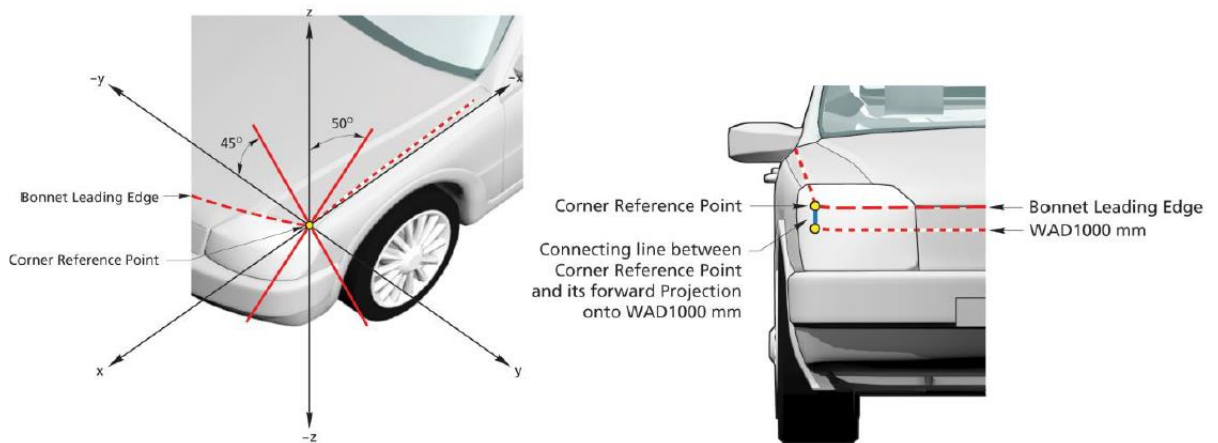

Figure 11: Determination of the corner reference point

### 3.9.3.7 Bumper Reference Lines

For vehicles with an identifiable bumper structure the upper Bumper Reference Line is defined as the geometric trace of the upper most points of contact between a straight edge and the bumper, when the straight edge, held parallel to the vertical longitudinal plane of the car and inclined rewards by 20 degrees, is traversed across the front of the car whilst maintaining contact with the upper edge of the bumper. For a vehicle with no identifiable bumper structure it is defined as the geometric trace of the upper most points of contact between a straight edge 700 mm long and the bumper, when the straight edge, held parallel to the vertical longitudinal plane of the car and inclined rewards by 20 degrees, is traversed across the front of the car, whilst maintaining contact with the ground and the surface of the bumper. See Figure 12.

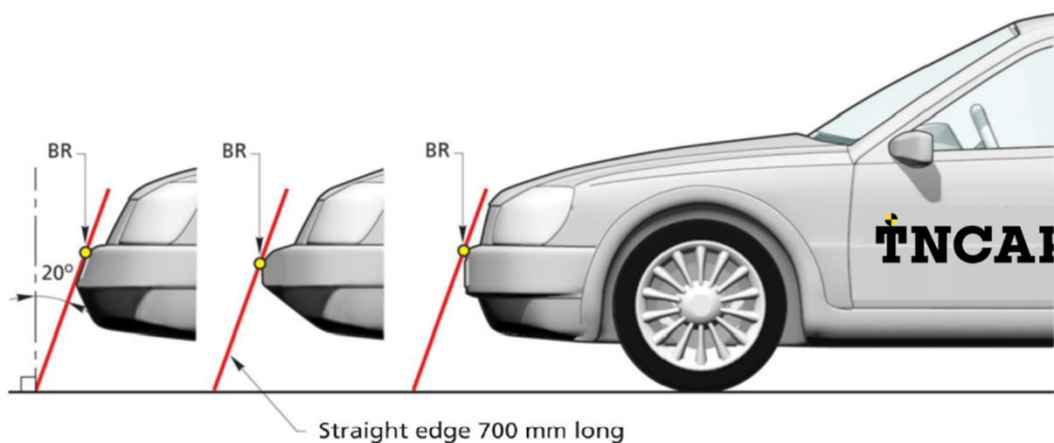

Figure 12: Determination of upper bumper reference line

3.9.3.7.1 With a 700mm straight edge fixed at 20° to the vertical and in a plane parallel to the vertical longitudinal plane of the car, position the straight edge at one end of, and in contact with, the bumper and the ground. The

straight edge may be shortened to avoid contact with structures above the bumper, the straight edge may also be lengthened to reach the bumper.

- 3.9.3.7.2 Mark the uppermost point of contact of the straight edge and bumper.
- 3.9.3.7.3 Pull the straight edge away from the bumper, move it towards the other end of the bumper by not more than 100mm and then into contact with the bumper.
- 3.9.3.7.4 Mark the uppermost point of contact of the straight edge and bumper.
- 3.9.3.7.5 Repeat Sections 3.9.3.7.3 and 3.9.3.7.4 along the whole of the length of the bumper.
- 3.9.3.7.6 Using a flexible rule, join the marks on the bumper to form a line. This line may not be continuous but may 'jump' around the license plate area etc. This line is the Upper Bumper Reference Line (UBRL).
- 3.9.3.7.7 The Lower Bumper Reference Line (LBRL) also needs to be marked on the vehicle. This line identifies the lower limit to significant points of pedestrian contact with the bumper. It is defined as the geometric trace of the lower most points of contact between a straight edge 700mm long and the bumper, when the straight edge, held parallel to the vertical longitudinal plane of the car and inclined forwards by 25°. It is traversed across the front of the car, while maintaining contact with the ground and with the surface of the bumper; see Figure 13.
- 3.9.3.7.8 Proceed as per Sections 3.9.3.7.2 to 3.9.3.7.6 this line is the Lower Bumper Reference Line (LBRL).

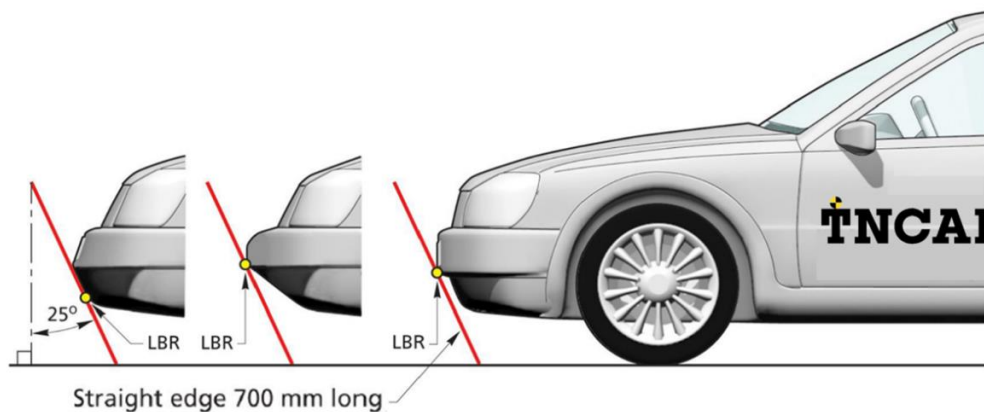

Figure 13: Determination of the Lower Bumper Reference Line

#### 3.9.3.8 Bumper Corners, Bumper Test Zone and Internal Bumper Reference Line

The Corner of Bumper is the point of contact of the vehicle with a vertical plane which makes an angle of 60° with the vertical longitudinal plane of the car and is tangential to the outer surface of the bumper, see Figure 14. Where multiple or

continuous contacts occur the most outboard contact shall form the bumper corner.

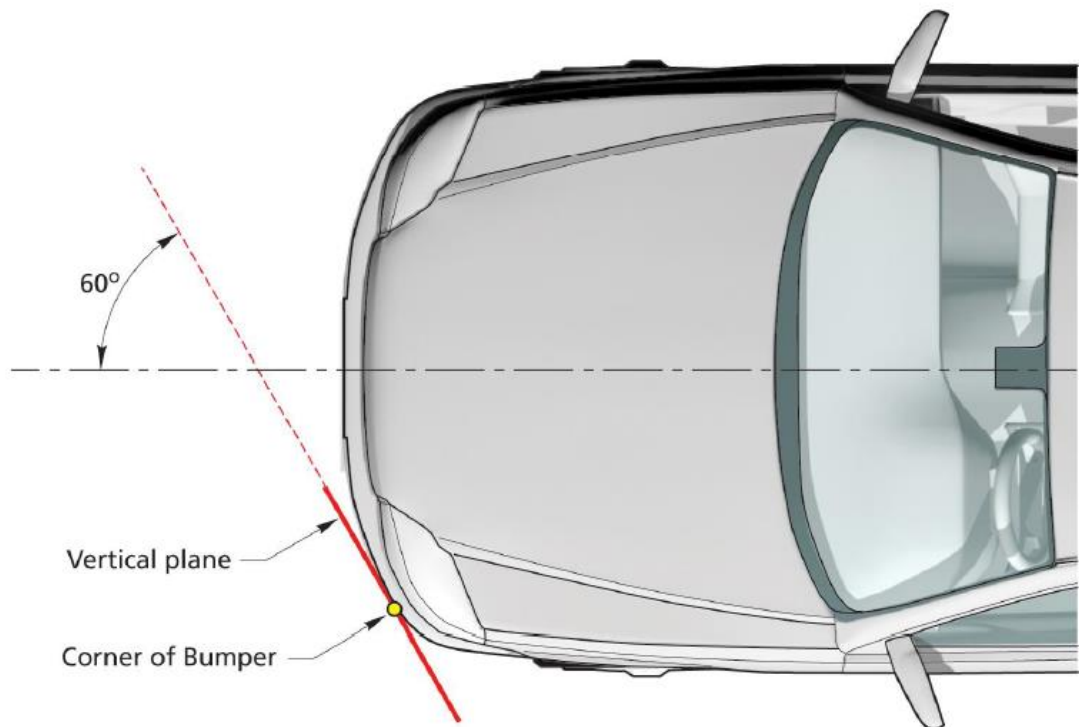

Figure 14 Determination of bumper corner

- 3.9.3.8.1 Fix a 700mm straight edge at  $60^\circ$  to the longitudinal direction of the car. With this edge horizontal move it into contact with the most forward part of the bumper.
- 3.9.3.8.2 Mark the point of contact between the straight edge and the bumper. This is the Bumper Corner.
- 3.9.3.8.3 If the bumper is angled at essentially  $60^\circ$ , so that the straight edge makes a continuous contact or multiple contacts rather than a point contact, the outermost point of contact shall be the Bumper Corner.
- 3.9.3.8.4 Repeat for the other side of the vehicle.
- 3.9.3.8.5 Mark a line across the bumper face at a vertical height of 520mm above ground reference level.
- 3.9.3.8.6 Remove the plastic bumper cover and any associated components such as padding and energy absorbers.
- 3.9.3.8.7 Identify the outermost ends of the bumper beam/lower rails/cross beam structures.
- 3.9.3.8.8 The bumper test zone is defined as either the area limited by the bumper corners or the outermost ends of the bumper beam/lower rails/cross beam structures, whichever is larger.
- 3.9.3.8.9 Record the distance from the vehicle centreline to the end of the bumper test zone.

3.9.3.8.10 To mark the internal bumper reference line (IBRL):

3.9.3.8.11 Measure the height of the bumper from a vertical plane contacting the beam up to 10mm into the profile to get the internal bumper reference line height at 100mm intervals outboard of the vehicle centreline. See Figure 15: Marking IBRL height.

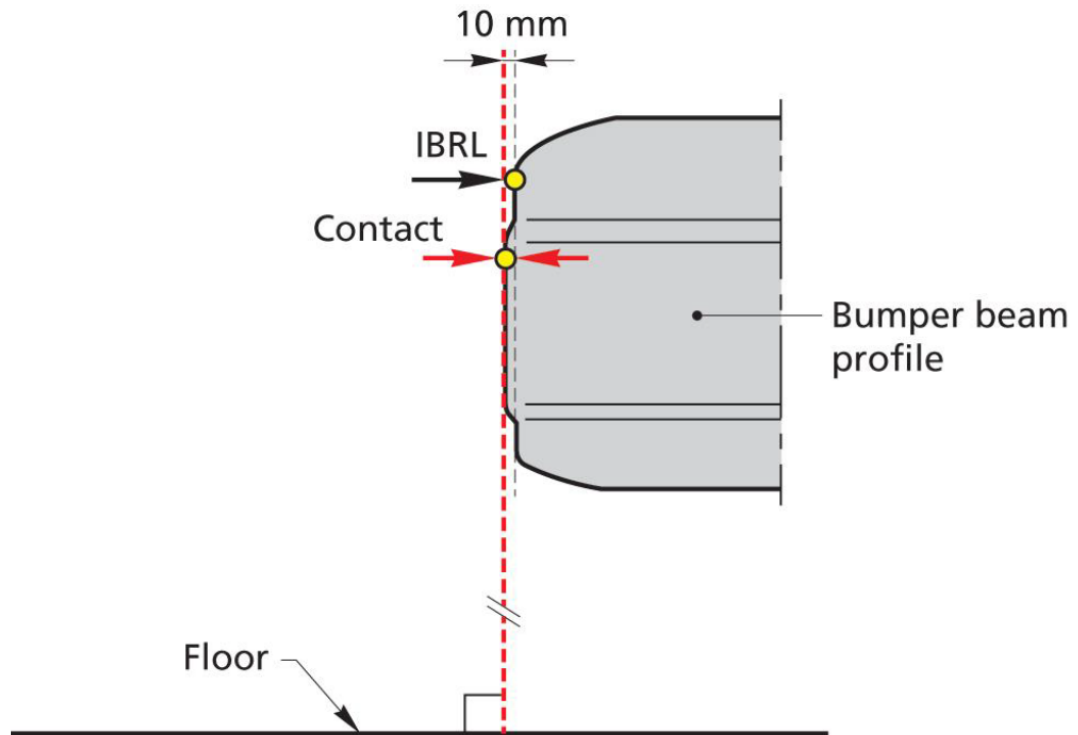

Figure 15: Marking IBRL height

3.9.3.8.12 A bumper beam will be deemed structural for determination of the IBRL where the minimum thickness is  $\geq 1\text{mm}$  for steel and  $\geq 2\text{mm}$  for aluminum.

3.9.3.8.13 For every upper legform grid point outboard of the bumper beam, use the average bumper beam height allocated to the outermost grid point on the bumper beam as defined in 3.9.3.8.14.

3.9.3.8.14 Divide the area between each 100mm mark into three areas of equal width. If the bumper beam extends by 33.3mm or more outboard of the outermost 100mm grid point, mark the distance of 33.3mm on the bumper beam. Take the average height of each 100mm mark and the adjacent two marks. The height at each 100mm interval is the average height of the 100mm mark and adjacent divisions, see Figure 16. If the end of the bumper beam is less than 33.3mm outboard of the outermost grid point, the average height is taken from the height of the grid point and the inboard adjacent mark only.

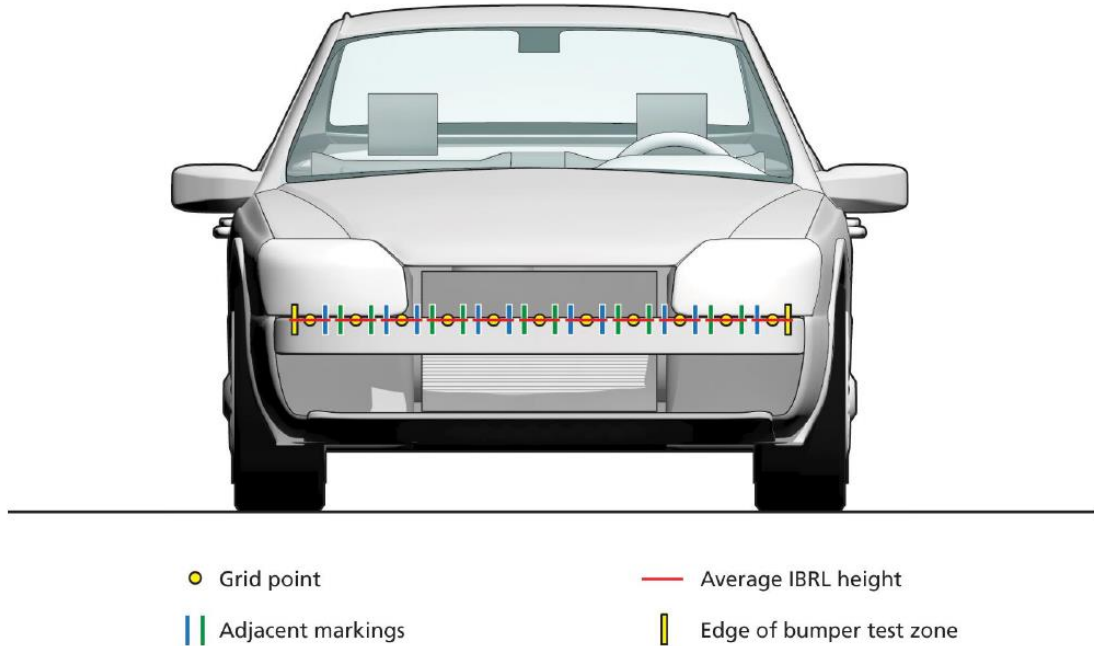

Figure 16: IBRL height at 100mm intervals

3.9.3.8.15 Replace the bumper components and mark both outermost ends of the bumper beam/lower rails/cross beam structures.

3.9.3.8.16 Transfer the average height of the beam calculated at each 100mm interval on the bumper beam onto the external bumper face.

3.9.3.8.17 The internal bumper reference line is then constructed using the heights marked on the bumper face in 3.9.3.8.16 up to a maximum height above ground reference level of 520mm. Where there are locations above 520mm, the internal reference line will be limited to no more than 520mm above ground reference level for those locations.

### 3.9.3.9 Marking Headform Impact Area Grid Points

3.9.3.9.1 Mark the longitudinal centreline of the vehicle on the bumper/grille, bonnet top, windscreen and roof.

3.9.3.9.2 Mark Wrap Around Distances (not lines) on the centreline only at 100mm intervals. Start from Wrap Around Distance 1000mm and end at Wrap Around Distance 2100mm. For vehicles with a V-shaped front end it may also be necessary to mark additional Wrap Around Distances of 2200mm, 2300mm, etc. See Figure 17.

3.9.3.9.3 Starting at one of the wrap around distance marks at the centreline, mark grid points every 100mm in both lateral directions up to the side reference lines. The 100mm distances are measured horizontally in a lateral vertical plane through the respective centreline mark and projected vertically onto the vehicle surface. Where a vehicle has the WAD 1000 mark on the vehicle centreline forward of the Bonnet

Leading Edge Reference Line and having the forward angle being more than  $60^\circ$  to the ground reference level the distances are projected horizontally onto the vehicle surface. The forward angle is defined as the angle to the ground reference level, of a straight line connecting the WAD 1000 mark on the centreline with the intersection point of the Bonnet Leading Edge Reference Line and the centreline. The angle designated by the manufacturer may be deemed as the forward angle if it deviates within  $\pm 2^\circ$  from the actual measurement. If due to the horizontal projection two grid points have a distance of less than 50 mm to each other, the horizontal projected grid point will be deleted. The distance shall be measured with a tautly held flexible tape.

3.9.3.9.4 Repeat step 3.9.3.9.3 for every wrap around distance on the vehicle centreline until the entire headform impact area is marked with grid points. Depending on the shape of the vehicle, (e.g. V-shaped vehicle front end) it may be necessary to also use the wrap around distance points at 2200mm, 2300mm, etc. See Figure 17.

3.9.3.9.5 For A-pillars only, mark an additional grid point at the intersection of the lateral vertical plane and the side reference line for each wrap around distance.

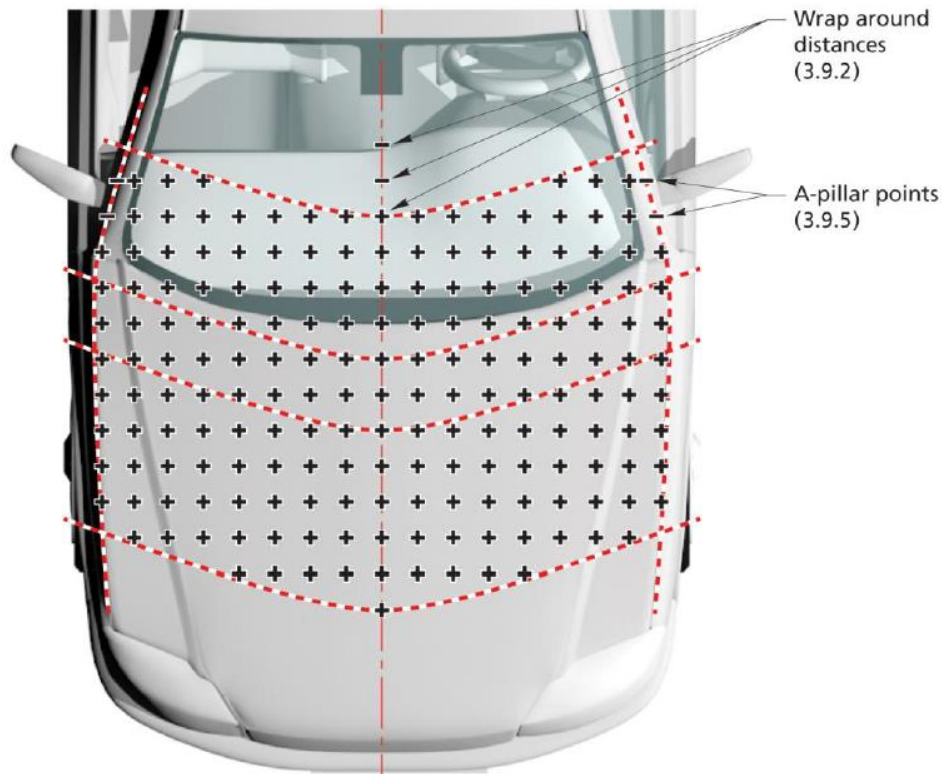

Figure 17: Grid points

3.9.3.9.6 Where any of the grid points lie underneath the outer contour of the

vehicle, for example in the gap behind the bonnet, approximate the outer contour of the vehicle horizontally rearward from the last point of contact by using an adhesive tape. Mark the grid point on the tape to replace the underlying grid point. See Figure 18.

- 3.9.3.9.7 Where a wiper obstructs the placement of the tape, the wiper shall be ignored during tape placement unless the grid point falls on the wiper itself.

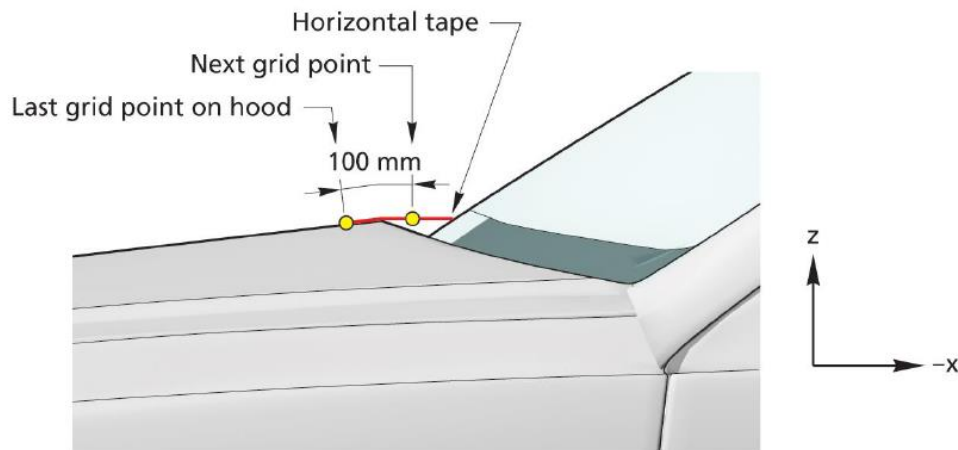

Figure 18: Grid points beneath outer contour (example at vehicle centreline)

- 3.9.3.9.8 Remove those grid points that have a distance, measured in the lateral Y axis, of less than 50mm to the side reference lines, excluding those points which are on A-pillar side reference line. See Figure 19.
- 3.9.3.9.9 The remaining grid points are used for the assessment of the vehicle. For impact testing, these grid points are the aiming points.
- 3.9.3.9.10 Where the vehicle is equipped with an active system, the aiming points will always be considered in the undeployed state.

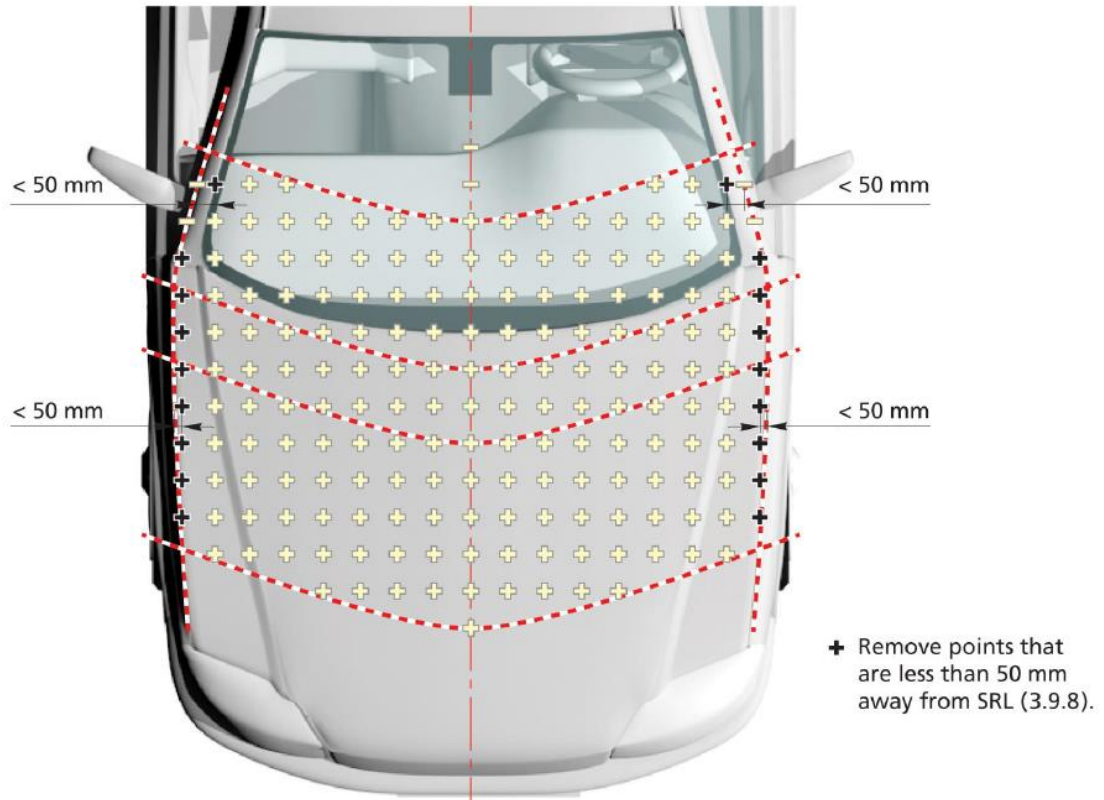

Figure 19: Deleting grid points that are less than 50mm away from side reference line

### 3.9.3.10 Identification of the Headform Grid Points

3.9.3.10.1 All child/small adult headform grid points will contain the prefix 'C'.

All adult headform points will contain the prefix 'A'.

3.9.3.10.2 The grid point will be identified by means of a row and column system.

The origin will be at the grid point on the vehicle centreline and the 1000mm WAD. This point is C0,0.

3.9.3.10.3 The rows at the origin will be row 0, the subsequent rows will be marked in increasing increments of 1 up to the rearmost row.

3.9.3.10.4 The column on the centreline will be column 0, the adjacent column on the right of the vehicle, as shown below, will be column +1, with the other columns increasing by 1 toward the SRL, i.e. +2, +3, ....+8. The column on the left of the vehicle will be column -1 with the other columns decreasing by 1 toward the SRL, i.e. -2, -3, ....-8.

3.9.3.10.5 Every point will be identified firstly by the relevant headform impactor (A or C), then by the row, then by the column. See Figure 20.



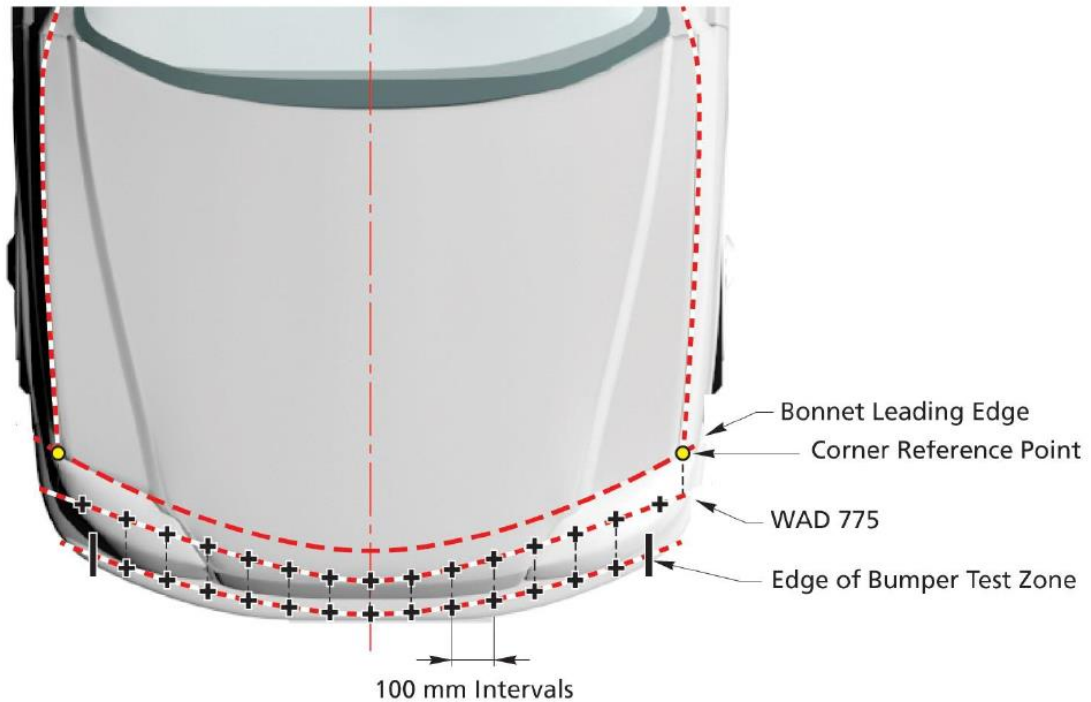

Figure 21: Division of the WAD775 and upper bumper reference lines

### 3.9.3.13 Labelling the Upper Legform and Legform Grid Points

3.9.3.13.1 All upper legform grid points will contain the prefix 'U'. All legform points will contain the prefix 'L'.

3.9.3.13.2 The grid points will be marked sequentially from the origin at the grid points on the vehicle centreline. For the upper legform, the origin will be marked U0. For the legform the origin will be marked L0.

3.9.3.13.3 The adjacent points on the right of the vehicle will be +1, with the other points increasing by 1 with outboard movement, i.e. +2, +3 etc. The points on the left of the vehicle -1 with the other columns decreasing by 1 i.e. -2, -3 etc.

3.9.3.13.4 Every point will be labelled firstly by the relevant impactor (U or L), then by the individual number. See Figure 22.

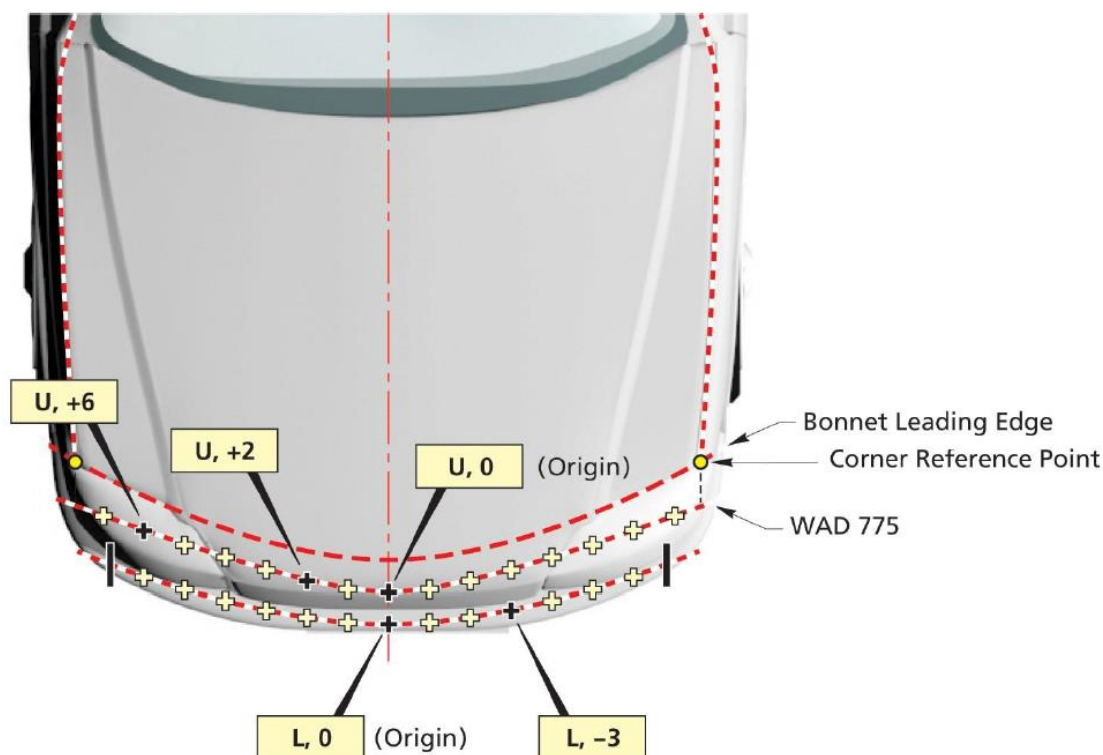

Figure 22: Labelling the Upper Legform and Legform grid points

### 3.9.4 Headform DATA

#### 3.9.4.1 Manufacturer Supplied Data

3.9.4.1.1 The vehicle manufacturer is required to provide the TNCAP executive agency with HIC<sub>15</sub> or color data detailing the protection offered by the vehicle at all headform grid locations.

3.9.4.1.2 All data must be supplied by the manufacturer before any vehicle marking or testing begins, preferably with delivery of the test vehicle(s).

3.9.4.1.3 For the headform area, data shall be provided for each grid point according to the following performance criteria:

HIC <sub>15</sub> < 650	= Green
650 ≤ HIC <sub>15</sub> < 1000	= Yellow
1000 ≤ HIC <sub>15</sub> < 1350	= Orange
1350 ≤ HIC <sub>15</sub> < 1700	= Brown
1700 ≤ HIC <sub>15</sub>	= Red

3.9.4.1.4 Some grid points shall have a default red or green rating awarded to them. These shall be clearly identified as defaulted in the predicted data. The only areas to be defaulted are as follows:

- (1) A-pillars = Default red (unless data is provided to suggest otherwise)
- (2) Windscreen glazing = Default green (except for areas defined in Section 3.9.4.1.5 to 3.9.4.1.7).

- 3.9.4.1.5 Any grid points that are within 165mm of the solid strip around the periphery of the windscreen mounting frame cannot be defaulted green. The 165mm shall be measured along the outer contour of the windscreen. See Figure 23.
- 3.9.4.1.6 Where there are any structures mounted directly behind the windscreen, such as sensor systems, the overlying grid points shall not be defaulted green.
- 3.9.4.1.7 Grid points on the windscreen that are within 100mm of ANY underlying structures in the windscreen base area, measured from the grid point in the impact direction of the relevant headform, cannot be defaulted green.
- 3.9.4.1.8 Where the vehicle manufacturer can provide evidence that shows an A-pillar is not red, those grid points will be considered in the same way as other points.
- 3.9.4.1.9 Grid points on the side reference line that are rearward of the bonnet rear reference line will be deemed as grid points on the A-pillars.
- 3.9.4.1.10 Defaulted locations are not included in the random selection of verification tests, see Section 3.9.5, and the correction factor calculation.
- 3.9.4.1.11 Before test points are selected, defaulted locations will be confirmed by the technical service.

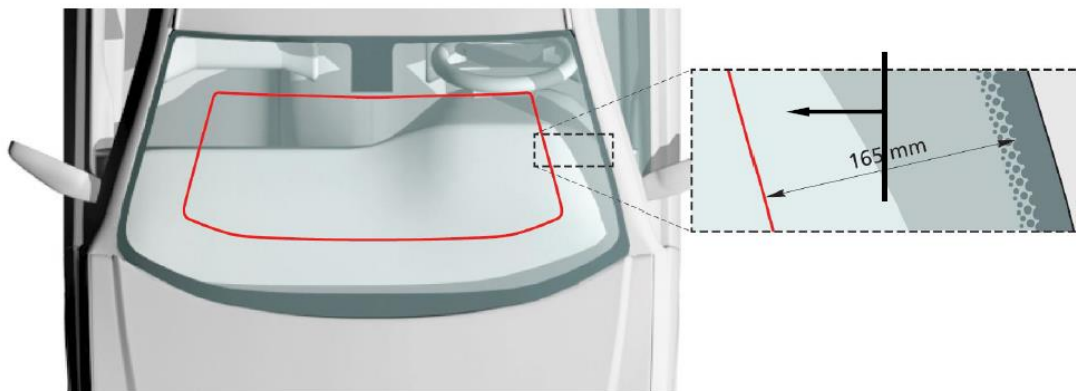

Figure 23: Windscreen periphery measurement

### 3.9.4.2 Unpredictable Grid Locations

- 3.9.4.2.1 Where certain structures are such that the protection offered by particular grid points is unpredictable, those grid points may be colored blue in the predicted data.
- 3.9.4.2.2 Those areas of the vehicle that may contain blue grid points are limited to the following structures:
- (1) Plastic scuttle
  - (2) Windscreen wiper arms and windscreen base
  - (3) Headlamp glazing

#### (4) Break-away structures

3.9.4.2.3 Where blue points are identified, the vehicle manufacturer must provide test results and/or CAE modelling as justification to show the unpredictable performance of the location(s).

3.9.4.2.4 Blue points, either singly or grouped together in pairs, will form a blue zone.

3.9.4.2.5 Where there are two grid points in a zone they must be adjacent (longitudinally, laterally and diagonally) to each other. A maximum of eight zones may be blue over the entire headform impact area.

3.9.4.2.6 The technical service will choose one blue point to assess each zone. Symmetry may be applied.

3.9.4.2.7 The test results of blue points will be applied to the grid point(s) in each zone. The color of each tested blue point will be changed from blue to the color corresponding to the HIC15 measured.

3.9.4.2.8 Blue point tests will not be used in the random selection of verification tests, see Section 3.9.5, and the correction factor calculation.

#### 3.9.4.3 Absence of Manufacturer Data

3.9.4.3.1 Where predicted data is NOT provided by the vehicle manufacturer, the vehicle sponsor may choose for ALL grid points to be tested by the technical service.

3.9.4.3.2 Alternatively, test points will be selected on a worst case performance basis by TNCAP executive agency and the technical service.

3.9.4.3.2.1 The bonnet marking and point selection for all impactors will follow that outlined in the Euro NCAP Pedestrian Testing Protocol version 5.3.1, November 2011.

3.9.4.3.2.2 The latest impactors will be used which are specified in Section 3.9.12.

3.9.4.3.2.3 The latest performance criteria (HIC650-1700) will be applied; details of the criteria are contained in the assessment protocol.

### 3.9.5 Headform Verification Tests

#### 3.9.5.1 Verification Tests

3.9.5.1.1 For vehicles under test (VUT) funded by the government, the cost of the 10 headform model verification tests will be covered by the government budget. If a vehicle manufacturer opts for assessment at its own expense, the cost of the 10 headform model verification tests will be the responsibility of the manufacturer.

3.9.5.1.2 The vehicle manufacturer has the option of sponsoring up to 10 additional headform verification tests. These are in addition to any blue

points and those selected by TNCAP. Where this is the case, the vehicle manufacturer must inform TNCAP of the number of tests when predicted data is provided. All expenses related to these additional verification tests, encompassing testing fees and component-related costs, are the responsibility of the vehicle manufacturer.

3.9.5.1.3 The location of all verification tests will be selected at the same time and at random by TNCAP executive agency and the technical service.

3.9.5.1.4 Only those grid points on defaulted grid positions or those colored blue will be excluded from the randomly selected points. All other grid points are eligible for selection.

3.9.5.1.5 There is no restriction as to the location of the randomly selected tests. Tests to adjacent impact locations are acceptable provided that permanent vehicle damage would not influence other test results.

3.9.5.1.6 Where damage from already tested grid points affects other verification tests, the TNCAP executive agency will be informed and will take a decision on how to proceed.

3.9.5.1.7 The results of all verification tests will be used in the calculation of a correction factor.

#### 3.9.5.2 Headform Tests

3.9.5.2.1 The selected grid point shall be treated as the aiming point for the headform impactor, with deployable system in the undeployed position.

3.9.5.2.2 The centreline of the headform impactor shall be directly in the line of flight toward the aiming point. See Figure 24.

3.9.5.2.3 The effect of gravity shall be considered when positioning the propulsion system for test. Under the influence of gravity the headform will deviate from the trajectory it has initially when leaving the propulsion system.

3.9.5.2.4 Gravity must be taken into account in order to establish the correct trajectory for the headform. The determination of where to position the firing mechanism will require the following information:

(1) Headform diameter.

(2) Distance that the headform must travel after leaving the propulsion system.

(3) Required angle of impact to horizontal.

(4) Angle of the bonnet top at the point of impact.

(5) Required impact velocity.

3.9.5.2.5 Using the above information calculate the distance from the aiming point to ensure that the required correct trajectory is established. The angle to which the propulsion system shall be set and the velocity that the

propulsion system must give to achieve the required velocity at impact and the required angle of incidence at impact must also be calculated.

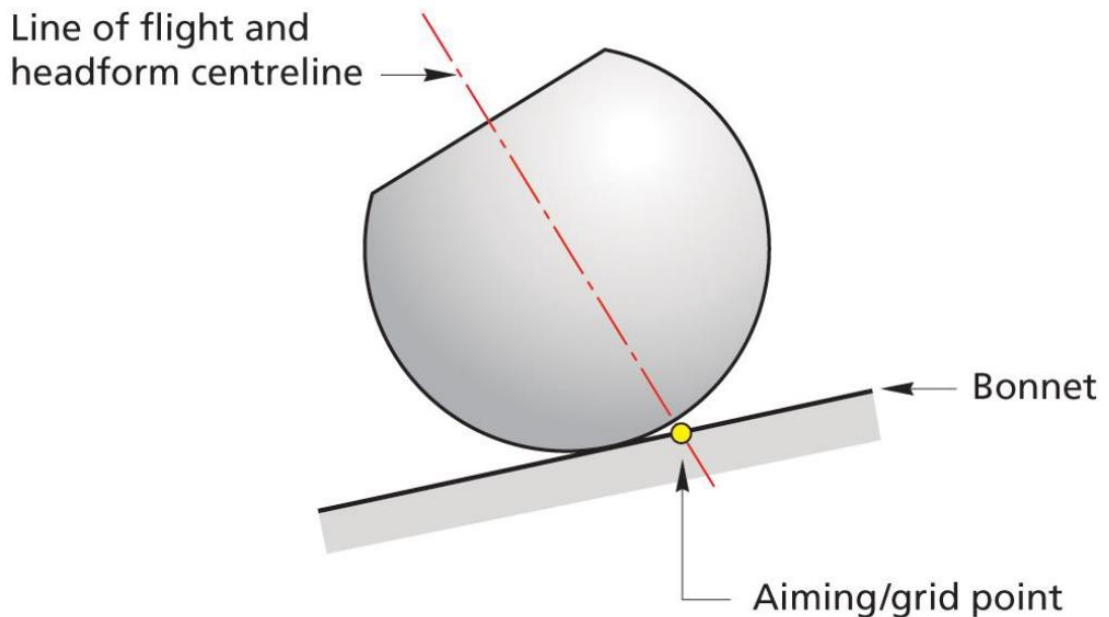

Figure 24: Aiming point

### 3.9.6 Determination of Upper Legform and Legform Impact Points

#### 3.9.6.1 Legform to Bumper Tests

3.9.6.1.1 The legform to bumper tests will be conducted if the lower bumper reference line at the chosen grid point is less than 425mm above the ground when the test vehicle is at its Normal Ride Attitude. For vehicles where part or all of the Lower Bumper Reference Line is above 425mm, select the bumper impact points as in Sections 3.9.6.1.2 to 3.9.6.1.4 and afterwards refer to Section 3.9.6.2.

3.9.6.1.2 The vehicle manufacturer must identify any asymmetrical grid points before the start location is selected and any nominations are made.

3.9.6.1.3 The TNCAP executive agency and the technical service will select one of the locations L0 or L1 for testing; additional tests will then be performed to every second grid point outboard of this point.

3.9.6.1.4 Symmetry is applied across the vehicle. Tests can be made on both sides of the vehicle. For each pair of symmetrical grid points the technical service chooses the point to be actually tested.

3.9.6.1.5 Grid points that have not been tested will be awarded the worst result from one of the adjacent points.

3.9.6.1.6 Where the vehicle manufacturer believes that the performance of a non selected point will not be reflected correctly or symmetry does not apply, they may choose to sponsor additional tests to any of these points.

Nominations must be made for both possible starting points and before the first point to test is chosen as detailed in Section 3.9.6.1.3. All costs associated with these additional tests, including testing fees and component-related expenses, are to be borne by the vehicle manufacturer.

### 3.9.6.2 Upper Legform to Bumper Tests

3.9.6.2.1 These tests are conducted, instead of the legform to bumper tests, where the Lower Bumper Reference Line at the position(s) defined in Section 3.9.6.1, is greater than 500mm vertically above the ground at the vehicle's normal ride attitude. Each grid point shall be regarded individually, i.e. it may be necessary to use the legform to bumper test and the upper legform to bumper test at different locations on the same vehicle.

3.9.6.2.2 Where the Lower Bumper Reference Line at and position defined in Section 3.9.6.1, is between 425mm and 500mm vertically above the ground at the vehicle's normal ride attitude, the vehicle manufacturer may choose to use either the Legform to bumper test or the Upper Legform to bumper test for this test point.

3.9.6.2.3 The upper legform to bumper tests must be carried out at the same lateral position as the points selected in Section 3.9.6.1, with the intersection of the longitudinal and lateral planes, at the centre of the impactor, aimed mid-way between the Upper Bumper Reference Line and the Lower Bumper Reference Line.

### 3.9.6.3 Upper Legform to WAD775mm Tests

3.9.6.3.1 A test is not required if the calculated impact energy would be less than 160J.

3.9.6.3.2 The vehicle manufacturer must identify any asymmetrical grid points before the start location is selected and any nominations are made.

3.9.6.3.3 The TNCAP executive agency and the technical service will select one of the locations U0 or U1 for testing; additional tests will then be performed to every second grid point outboard of this point.

3.9.6.3.4 Symmetry is applied across the vehicle. Tests can be made on both sides of the vehicle. For each pair of symmetrical grid points the technical service chooses the point to be actually tested.

3.9.6.3.5 Grid points that have not been tested will be awarded the worst result from one of the adjacent points.

3.9.6.3.6 Where a point is to be awarded a symmetrical or adjacent result, there must be no more than a 10% difference in the calculated impact energy

between the two points. Where the energy differs by more than 10%, a test is required.

3.9.6.3.7 Where the vehicle manufacturer believes that the performance of a non selected point will not be reflected correctly or symmetry does not apply, they may choose to sponsor additional tests to any of these points. Nominations must be made for both possible starting points and before the first point to test is chosen as detailed in Section 3.9.6.1.2.

### 3.9.7 Recording the Impact Point Locations

#### 3.9.7.1 General

3.9.7.1.1 A three dimensional measuring system with an accuracy of  $\pm 0.5\text{mm}$  shall be used to record the grid origin and the points chosen for test. For all impact locations, record the position of the selected impact points.

3.9.7.1.2 Care shall be taken at all times not to move the vehicle while the impact points are being recorded or transferred.

#### 3.9.7.2 Measuring Impact Points

3.9.7.2.1 Ensure that the vehicle is at its test weight and fully test prepared as defined in Section 3.9.1.

3.9.7.2.2 Measure the ride heights at all four wheels using the marks defined in Section 3.9.1.3.4. Record the ride heights in the test details.

3.9.7.2.3 During digitizing, care shall be taken not to move the vehicle by, for example, leaning on it.

3.9.7.2.4 The co-ordinates of all impact locations shall be digitized with the 3D arm.

3.9.7.2.5 A hard copy of the impact points co-ordinates shall be obtained for reference.

3.9.7.2.6 After digitization, the bonnet top and bumper featuring all the impact points shall be removed and replacements fitted. See Section 3.9.8.3 for fitting procedures.

3.9.7.2.7 The original bonnet and bumper shall be kept for reference and will be replaced on the vehicle once testing is complete.

#### 3.9.7.3 Transferring Impact Points to Replacement Vehicle Parts

3.9.7.3.1 Replacement parts will need to be fitted to the vehicle for the series of tests. It is not practical to have to mark out each of the parts completely for a single test. Therefore, the original marked-out bonnet will be retained as a reference and individual impact locations transferred to replacement components.

3.9.7.3.2 With the new component(s) fitted, measure the ride heights at all four wheels.

3.9.7.3.3 These ride heights must be altered until they match the original recorded ride heights measured in Section 3.9.1.3. If the ride heights are too high then they can be reduced by adding weights. If the ride heights are too low then they can be increased by removing weight from the vehicle and/or inserting blocks under the body of the vehicle. The additional weights and/or blocks shall be removed before testing.

3.9.7.3.4 Set up the 3D measuring system.

3.9.7.3.5 Using the co-ordinates recorded in Section 3.9.7.2 for the original impact points, locate and mark the desired impact point on the new component.

### 3.9.8 Performing of Pedestrian Impact Tests

#### 3.9.8.1 General

3.9.8.1.1 Safety to personnel shall be a priority at all times.

3.9.8.1.2 Ensure that all equipment used is in full working order, has been checked for safety and is in calibration where appropriate.

#### 3.9.8.2 Propulsion System

3.9.8.2.1 An air, spring or hydraulic gun will be used to propel the various body form impactors.

3.9.8.2.2 For the legform and the headform tests the impactors are required to be in free flight at the time of impact.

#### 3.9.8.3 Fitting Replacement Parts to Vehicles

3.9.8.3.1 Careful note shall be taken before any testing is performed as to how any parts liable to need replacement are fitted to the vehicle structure.

3.9.8.3.2 Fitting of parts shall not increase or decrease the strength of the structure of the vehicle.

3.9.8.3.3 If significant repair work is required, this will be done at a manufacturer-approved dealer.

#### 3.9.8.4 Photographic Record

3.9.8.4.1 A photographic record shall be kept of each test.

3.9.8.4.2 Before any testing has been conducted but after the vehicle is fully test prepared including all markings, the vehicle shall be photographed according to the following schedule. Note that these shall be the only pre-test photographs taken.

#### 3.9.8.4.3 List of still photographs

<u>Amount of vehicle visible</u>	<u>View Point</u>
Full vehicle	Left side
Full vehicle	Right side
Front third vehicle	Left side
Front third vehicle	Right side

Full vehicle	Front
Left half vehicle	Front
Right half vehicle	Front
Front third of vehicle	Top
Front third, right half of vehicle	Top
Front third, left half of vehicle	Top
Legform test point	Front
Upper legform test points	Front
Child head zone test points	Top
Adult head zone test points	Top

3.9.8.4.4 Post-test photographs are detailed for each test type in the individual test procedures.

### 3.9.8.5 Testing Active Systems

#### 3.9.8.5.1 Static pedestrian tests

3.9.8.5.1.1 Static pedestrian tests will be performed in the normal way and according to the usual tolerances.

#### 3.9.8.5.2 Dynamic pedestrian tests

3.9.8.5.2.1 Where dynamic tests are required, only a lateral impact tolerance of +/-10mm will be required. The headform shall be aimed at the grid point, the subsequent impact location on the vehicle will then be determined by the timing of the system deployment relative to the propulsion of the headform.

3.9.8.5.2.2 The vehicle manufacturer will be required to provide Euro NCAP with data from numerical simulations performed with the bonnet in the undeployed position. Simulations are to be conducted with a vehicle speed of 40km/h with all pedestrian statures that result in head contact to bonnet. Pedestrian models shall be selected from the following statures, a 6 year old, 5th percentile female, 50th percentile male and 95th percentile male. The pedestrian position and stance to be used in the model is defined in Euro NCAP Technical Bulletin TB 024 Version 1.1.

3.9.8.5.2.3 From the simulations both head impact time (HIT as defined in Euro NCAP TB 024 Version 1.1) and the wrap around distance shall be recorded.

3.9.8.5.2.4 A graph shall be plotted with a best fit straight line as shown in Figure 25. When a test point is selected, as the wrap distance will be known, the equivalent head impact time can be obtained from the graph that will be used in the dynamic test set up.

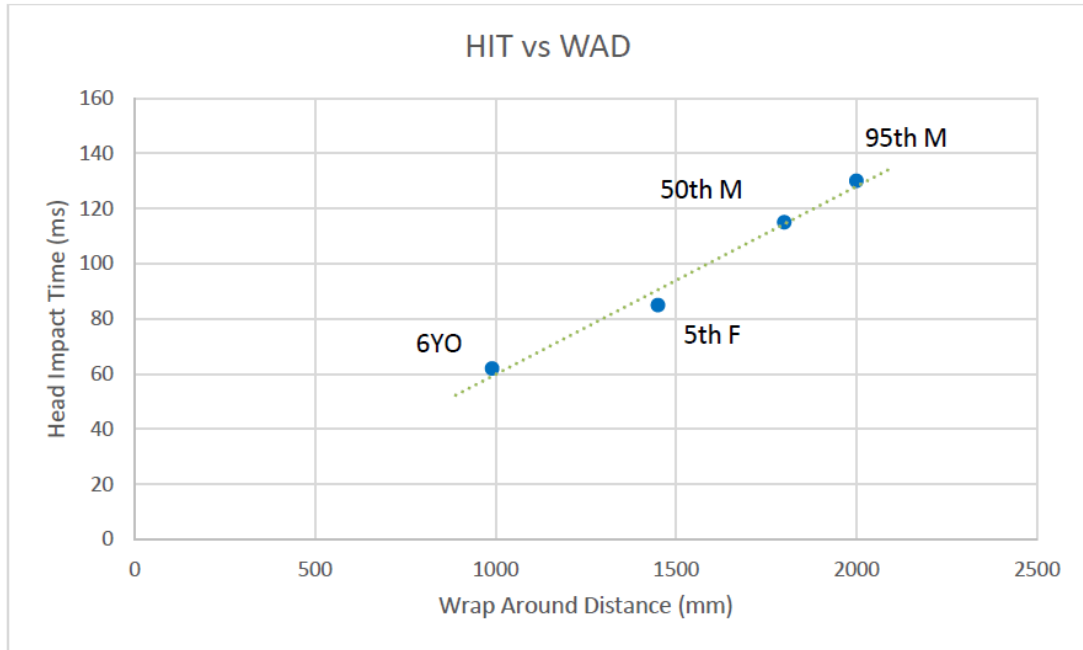

Figure 25: WAD vs HIT

3.9.8.5.2.5 The vehicle manufacturer must provide the technical service with all the necessary details of how to trigger the system, monitor trigger signals and replace spare parts.

### 3.9.8.5.3 Upper leg testing

3.9.8.5.3.1 If deployment occurs prior to pedestrian contact with the WAD775mm, creating an increased hazard such as increased height, the TNCAP executive agency will give consideration to marking out the WAD775mm in the deployed state.

3.9.8.5.3.2 Unless there is concern about additional hazards being created by the system deploying prior or during pedestrian contact with the WAD775mm, all upper legform testing will be carried out with the system in the un-deployed state.

3.9.8.5.3.3 Where the vehicle manufacturer provides data showing that a deployable system offers protection to the upper leg, the upper legform tests will be carried out by conducting dynamic tests.

## 3.9.9 Legform Tests

### 3.9.9.1 Description of Legform and its Instrumentation

3.9.9.1.1 The legform impactor used shall conform to that specified in UN Regulation No. 127 Revision 2, Annex 4.

#### 3.9.9.1.2 Instrumentation:

Location	Measurement	CFC(Hz)	CAC	No. of Channels

Tibia Bending	Tibia-1	180	400Nm	4
	Tibia-2			
	Tibia-3			
	Tibia-4			
Knee Elongation	Medial collateral ligament Anterior cruciate ligament Posterior cruciate ligament	180	30mm	3
Tibia*	Acceleration	180	500g	1

Note: \* Optional

### 3.9.9.2 Certification

3.9.9.2.1 The certification procedures are detailed in UN Regulation No. 127 Revision 2, Annex 6, Chapter 1.4.

3.9.9.2.2 The legform shall be re-certified after a maximum of 20 impacts and at least once every 12 months.

3.9.9.2.3 If the legform exceeds any of its lower performance limits then it shall be re-certified.

3.9.9.2.4 The legform shall be re-certified according to the procedures prescribed in UN Regulation No. 127 Revision 2, Annex 6, Chapter 1.2 at least once a year.

### 3.9.9.3 Test Procedure - Pre-test

3.9.9.3.1 Ensure that the vehicle is fully test prepared as described in Section 3.9.1.

3.9.9.3.2 Ensure that the legform, the vehicle, the propulsion system and the data acquisition equipment has soaked in a temperature in the range of 16°C to 24°C for at least 4 hours prior to testing.

3.9.9.3.3 Align the vehicle so that the propulsion system can aim at the impact position and the propulsion system can fire the legform in a direction that is parallel to the vehicle centre line.

3.9.9.3.4 Roll the vehicle forwards to give the desired free flight distance.

3.9.9.3.5 At the time of first contact the bottom of the legform shall be 75mm above Ground Reference Level  $\pm 10$ mm. The measurement must be taken from the bottom of the legform without any protective covers.

3.9.9.3.6 Insert blocks under the wheels of the vehicle such that vehicle height is raised as required by the gravity correction method used to ensure the above tolerance; and the tolerance for direction of impact are both satisfied. Alternatively, ensure that the vehicle is positioned above a trench in the floor. See Figure 26.

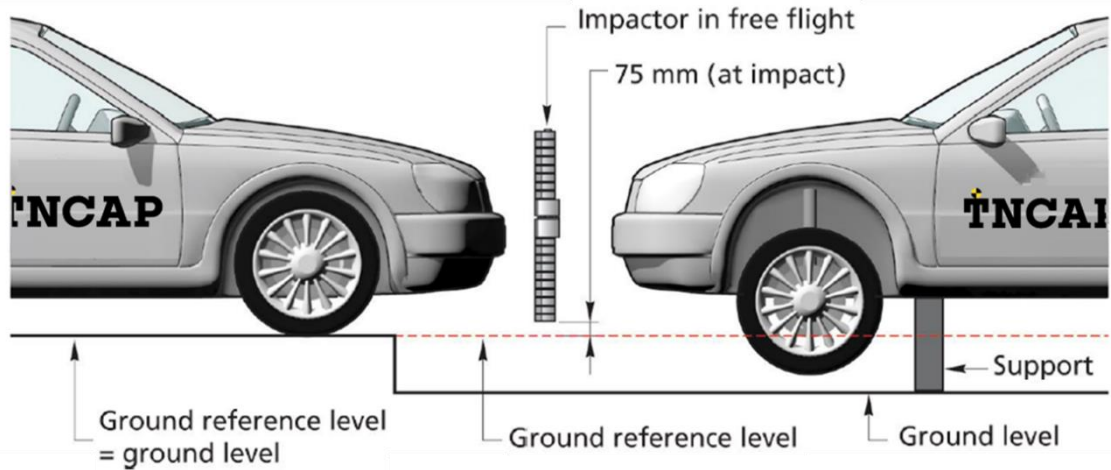

Figure 26: Legform to Bumper tests

3.9.9.3.7 If required, ensure the vehicle is at the same ride heights as those recorded during marking up of the vehicle, friction in the vehicle's suspension system may be a source of variance.

3.9.9.3.8 To ensure that the legform impacts with its bottom at the correct height above the ground a correction to take into account the action of gravity when the legform is in free flight is required. This can take the form of raising the legform a distance  $h$ , and firing it horizontally so that the action due to gravity results in the bottom of the impactor being at 75mm above ground level at the point of first contact with the vehicle. This can be achieved using the method in Section 3.9.9.4. However, this method will only remain within the tolerance specified in 3.9.9.5.9 if its free flight distance is about 400mm or less. For test houses that use a free flight distance of more than 400mm then the legform shall be fired using a ballistic correction procedure as described in Section 3.9.9.5.

#### 3.9.9.4 Compensation for Gravity (horizontal firing)

3.9.9.4.1 Measure the distance  $d$  (in meters) between the point of first contact and the point from where the legform will leave the propulsion system and begin free flight (release point).

3.9.9.4.2 The distance that the legform will fall due to gravity can be calculated from the formula:

$$\text{Fall due to Gravity } h = \frac{gd^2}{2v^2}$$

Assuming values for  $g$ , acceleration due to gravity =  $9.81 \text{ ms}^{-2}$  and  $v$ , exit velocity of the legform from the propulsion system (at the release point) =  $11.1 \text{ ms}^{-1}$  gives:

$$\text{Fall due to Gravity } h = 0.03981d^2$$

3.9.9.4.3 Raise the propulsion system by this calculated amount,  $h$ . The angle  $\theta$  must remain within the tolerance specified in Section 3.9.9.5.9. See Figure 27.

3.9.9.4.4 Proceed to Section 3.9.9.5.8.

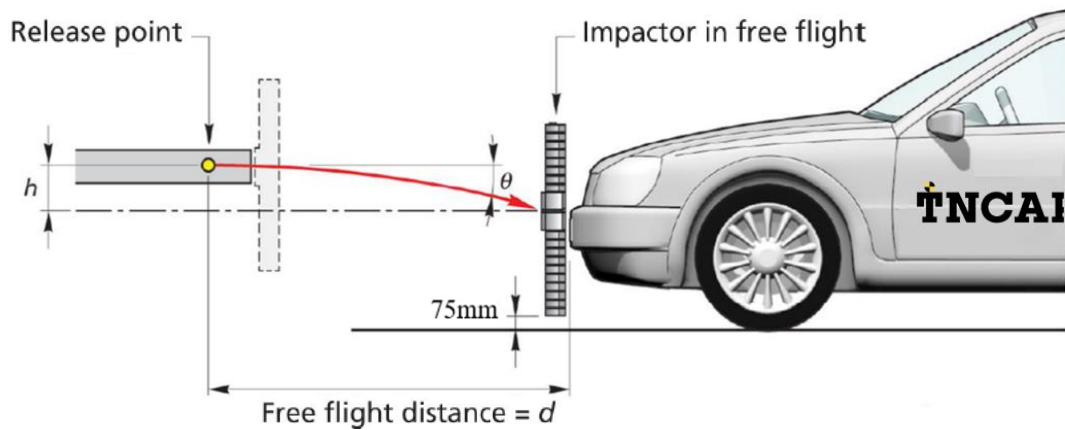

Figure 27: Droop Compensation

### 3.9.9.5 Ballistic Compensation

There are two procedures which can be used for ballistic compensation, it is at the discretion of the test house as to the most appropriate method, see Figure 28. The terms used for the calculations are:

At the release point	At the point of first contact
$u$ = initial velocity	$v$ = impactor velocity (11.1m/s)
$\phi$ = firing angle	$\theta$ = direction of impact ( $\theta^\circ$ )
	$d$ = free flight distance
	$h$ = height increase

3.9.9.5.1 The first case is where  $\phi$  is fixed, and  $\theta = 0^\circ$ ,  $v = 11.1\text{m/s}$ . The vehicle must be positioned in relation to the fixed propulsion system, therefore  $u$ ,  $d$ , and  $h$  are the subjects.

3.9.9.5.2 Using the following equations find  $u$ ,  $d$ , and  $h$ :

$$u = \frac{v}{\cos(\phi)}$$

$$d = \frac{v^2}{g} \tan(\phi)$$

$$h = \frac{v^2}{2g} \tan^2(\phi)$$

3.9.9.5.3 Position the vehicle to be the correct distance away from, and height above the release point. Proceed to Section 3.9.9.5.8.

3.9.9.5.4 The second case is where  $d$  is fixed, and  $\theta = 0^\circ$ ,  $v = 11.1\text{m/s}$ . The

propulsion system is positioned and aimed in relation to the vehicle, therefore  $u$ ,  $h$  and  $\phi$  are the subjects.

3.9.9.5.5 Using the following equations find  $u$ ,  $h$  and  $\phi$ :

$$u = v \left( 1 + \frac{g^2 d^2}{v^4} \right)^{\frac{1}{2}}$$

$$h = \frac{gd^2}{2v^2}$$

$$\phi = \tan^{-1} \left( \frac{gd}{v^2} \right)$$

3.9.9.5.6 Position the propulsion system to be the correct distance away from, height above and correctly aimed at the vehicle.

3.9.9.5.7 The angle  $\phi$  shall be set so that the impactor is at the top of the ballistic at the point of first contact.

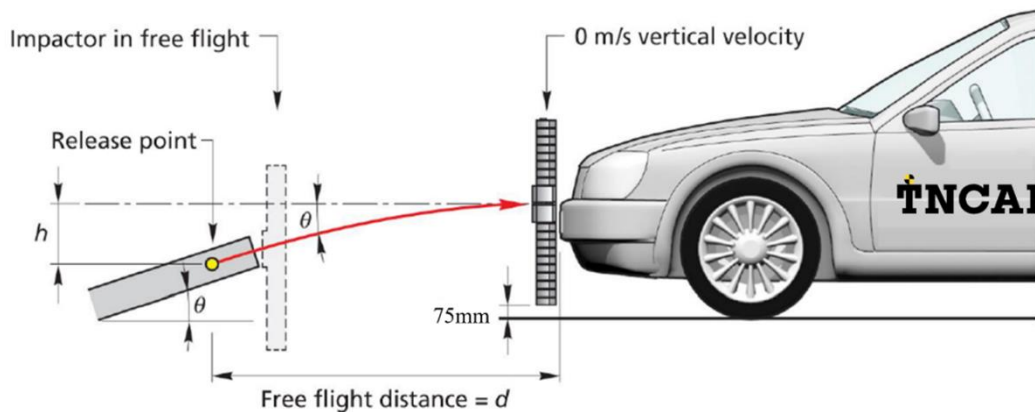

Figure 28: Ballistic Correction Procedure

3.9.9.5.8 Set the speed control on the propulsion system to give  $11.1\text{m/s} \pm 0.2\text{m/s}$  at the point of first contact. The velocity measuring device shall be able to measure to an accuracy of at least  $\pm 0.02$  m/s. The effect of gravity shall be taken into account when the impact velocity is obtained from measurements taken before the point of first contact.

3.9.9.5.9 The direction of impact at the point of first contact shall be in the horizontal plane and parallel to the longitudinal vertical plane of the vehicle. The axis of the legform shall be vertical at the time of first contact. The tolerance to these directions is  $\pm 2^\circ$ .

3.9.9.5.10 At the time of first contact the impactor shall have the intended orientation about its vertical axis, for correct operation of the knee joint,

with a tolerance of  $\pm 2^\circ$ .

3.9.9.5.11 The bending moments shall be  $\pm 10.0\text{Nm}$  within the 30ms immediately prior to impact.

3.9.9.5.12 At the time of first contact the centre line of the legform impactor shall be within  $\pm 10\text{mm}$  of the selected impact point.

3.9.9.5.13 It is recommended that the above tolerances are halved for the purposes of TNCAP testing.

3.9.9.5.14 During contact between the legform impactor and the vehicle, the impactor shall not contact the ground or any object not part of the vehicle.

3.9.9.5.15 Fire the propulsion system to commence the test.

#### 3.9.9.6 Test Procedure - Post Test

3.9.9.6.1 Take at least two still photographs of the resultant dent, one from the side and one from the front. Each photograph shall have some means of identifying the vehicle and test location. The preferred method shall be to use unique run numbers for each test.

3.9.9.6.2 Additional photographs may be required for an individual test at TNCAP discretion.

3.9.9.6.3 Check that no CAC has been exceeded before conducting the next test, if this has occurred then the impactor must be re-certified before the next test.

3.9.9.6.4 Replace any damaged part of the vehicle that will affect the results of the next test with new parts according to Section 3.9.8.3.

3.9.9.6.5 Repeat procedure for the next impact location.

### 3.9.10 Upper Legform to Bumper Tests

#### 3.9.10.1 Description of Upper Legform and its Instrumentation

3.9.10.1.1 The upper legform impactor used shall conform to that specified in UN Regulation No. 127 Revision 2, Annex 4.

#### 3.9.10.1.2 Instrumentation:

Location	Measurement	CFC (Hz)	CAC	No. of Channels
Upper femur	Force	180	10kN	1
Lower femur	Force	180	10kN	1
Centre of femur	Bending moment	180	1000Nm	1
50mm above center of femur	Bending moment	180	1000Nm	1
50mm below center of femur	Bending moment	180	1000Nm	1

#### 3.9.10.2 Certification

The official provisions are written in Chinese, this English edition is for your reference only.

- 3.9.10.2.1 The certification procedures are detailed in Regulation UN Regulation No. 127, Revision 2, Annex 6, Chapter 2.
- 3.9.10.2.2 The foam sheet from which the pieces of foam shall be taken shall be certified before the test program. The foam shall be 25mm thick Confor™ foam type CF-45 or equivalent.
- 3.9.10.2.3 The upper legform shall be re-certified after a maximum of 20 impacts and at least once every 12 months.
- 3.9.10.2.4 If the upper legform exceeds any of its lower performance limits then it shall be re-certified.

### 3.9.10.3 Test procedure - Pre-test

- 3.9.10.3.1 Ensure that the vehicle is fully test prepared as described in Section 3.9.1.
- 3.9.10.3.2 Ensure the vehicle is at the normal ride attitude as recorded during marking up of the vehicle.
- 3.9.10.3.3 Ensure that the upper legform, the vehicle, the propulsion system and the data acquisition equipment has soaked in a temperature in the range of 16°C to 24°C for at least 2 hours prior to testing.
- 3.9.10.3.4 The total mass of the upper legform impactor including those propulsion and guidance components which are effectively part of the impactor during the impact shall be 9.5kg ±0.1kg. The upper legform impactor mass may be adjusted from this value by up to ±1kg, provided the required impact velocity is also changed using the formula:

$$V = \sqrt{\frac{1170}{M}}$$

Where: V= impact velocity (m/s)

M= mass (kg), measured to an accuracy of better than ±1%.

- 3.9.10.3.5 The total mass of the front member and other components in front of the load transducer assemblies, together with those parts of the load transducer assemblies in front of the active elements, but excluding the foam and skin, shall be 1.95 ± 0.05kg.
- 3.9.10.3.6 Fit new pieces of foam, from the certified sheet of foam, to the upper legform.
- 3.9.10.3.7 Align the vehicle so that the propulsion system can aim at the impact position as defined in Section 3.9.6.1 and the propulsion system can propel and guide the upper legform in a direction that is parallel to the vehicle centre line ±2°. At the time of first contact the impactor centre line shall be midway between the Upper Bumper Reference Line and the Lower Bumper Reference Line with ±10 mm tolerance and laterally

with the selected impact location with a tolerance of  $\pm 10$  mm.

3.9.10.3.8 The impact velocity of the upper legform impactor when striking the bumper shall be  $11.1\text{m/s} \pm 0.2\text{m/s}$ . The velocity measuring device shall be able to measure to an accuracy of at least  $\pm 0.02$  m/s. The effect of gravity shall be taken into account when the impact velocity is obtained from measurements taken before the point of first contact.

3.9.10.3.9 Roll the vehicle forwards to give the desired distance, so that the impactor strikes the vehicle after it has been accelerated to the test speed and so that any end stops on the guidance system do not interfere with its interaction with the vehicle.

3.9.10.3.10 The direction of impact shall be in the horizontal plane and parallel to the longitudinal vertical plane of the vehicle. The axis of the upper legform shall be vertical at the time of first contact. The tolerance to these directions is  $\pm 2^\circ$ .

3.9.10.3.11 Fire the propulsion system to commence the test.

#### 3.9.10.4 Test Procedure - Post Test

3.9.10.4.1 Take at least two still photographs of the resultant dent, one from the side and one from the front. Each photograph shall have some means of identifying the vehicle and test location. The preferred method shall be to use unique run numbers for each test.

3.9.10.4.2 Additional photographs may be required for an individual test at TNCAP discretion.

3.9.10.4.3 Check that no CAC has been exceeded before conducting the next test, if this has occurred then the impactor must be re-certified before the next test.

3.9.10.4.4 Replace any damaged part of the vehicle which would affect the results of the next test with new parts according to Section 3.9.8.3.

3.9.10.4.5 Repeat procedure for the next impact location.

### 3.9.11 Upper Legform to WAD775mm Tests

#### 3.9.11.1 Description of Upper Legform and its Instrumentation

3.9.11.1.1 The upper legform used shall conform to that specified in UN Regulation No. 127 Revision 2, Annex 4.

#### 3.9.11.1.2 Instrumentation:

Location	Measurement	CFC (Hz)	CAC	No. of Channels
Upper femur	Force	180	10kN	1
Lower femur	Force	180	10kN	1

Centre of femur	Bending moment	180	1000Nm	1
50mm above center of femur	Bending moment	180	1000Nm	1
50mm below center of femur	Bending moment	180	1000Nm	1

### 3.9.11.2 Certification

3.9.11.2.1 The certification procedures are detailed in Regulation UN Regulation No. 127 Revision 2 Annex 6, Chapter 2.

3.9.11.2.2 The foam sheet from which the pieces of foam shall be taken shall be certified before the test program. The foam shall be 25mm thick Confor™ foam type CF-45 or equivalent.

3.9.11.2.3 The upper legform shall be re-certified after a maximum of 20 impacts and at least once every 12 months.

3.9.11.2.4 If the upper legform exceeds any of its lower performance limits then it shall be re-certified.

### 3.9.11.3 Determination of Impact Angle, Impact Energy and Impact Velocity

3.9.11.3.1 The impact angle  $\alpha$  in relation to the ground at each grid point is perpendicular to a straight line passing through the internal bumper reference line and WAD930mm at the same lateral position from the vehicle centreline. Measure and record the angle  $\alpha$  at each grid point to be tested.

3.9.11.3.2 The nominal impactor energy to be used in the test shall be calculated using the following formula:

$$En = 0.5 \times m_n \times v_c^2$$

Where:

$$\begin{aligned} m_n &= 7.4kg \\ v_c &= v_o \cos(1.2\alpha) \\ v_o &= 11.11 \frac{m}{s} \end{aligned}$$

3.9.11.3.3 The test velocity  $V_t$  shall then be adjusted to meet the nominal energy by using the following formula:

$$vt = \sqrt{\frac{2En}{10.5kg}}$$

### 3.9.11.4 Test procedure - Pre-test

3.9.11.4.1 Ensure that the vehicle is fully test prepared as described in Section 3.9.1.

3.9.11.4.2 Ensure the vehicle is at the same ride heights as those recorded during marking up of the vehicle.

3.9.11.4.3 Ensure that the upper legform, the vehicle, the propulsion system and the data acquisition equipment has soaked in a temperature in the range

of 16°C to 24°C for at least 2 hours prior to testing.

- 3.9.11.4.4 Fit a new piece of foam to the upper legform impactor from the certified sheet of foam.
- 3.9.11.4.5 Apply weights to the back of the upper legform impactor to bring the total mass to 10.5kg. Larger weights shall first be applied and various smaller weights shall then be added to achieve the correct weight. The upper legform impactor mass shall be measured to an accuracy of better than  $\pm 1\%$ .
- 3.9.11.4.6 Where  $\alpha < 0^\circ$ , then  $\alpha = 0^\circ$ . The impact will be in the same Y-Z plane as each grid point. The tolerances to these directions are  $\pm 2^\circ$ .
- 3.9.11.4.7 The upper legform impactor shall be aligned such that the centre line of the propulsion system and the longitudinal axis of the upper legform impactor are in the fore and aft vertical plane of the section of the vehicle to be tested. The tolerances to these directions are  $\pm 2^\circ$ . At the time of first contact the impactor centre line shall be coincident with the WAD775mm with a  $\pm 10$ mm tolerance, and laterally with the selected impact location with a tolerance of  $\pm 10$ mm.
- 3.9.11.4.8 Adjust the propulsion system to give the correct velocity and angle of incidence at the point of impact with the tolerance on the impact velocity being  $\pm 2\%$ . The effect of gravity shall be taken into account when the impact velocity is obtained from measurements taken before the first point of contact. The velocity measuring device shall be able to measure to an accuracy of at least  $\pm 0.02$ m/s. The effect of gravity shall be taken into account when the impact velocity is obtained from measurements taken before the point of first contact. The tolerance on impact direction  $\pm 2^\circ$ .
- 3.9.11.4.9 Roll the vehicle forwards to give the desired distance, so that the impactor strikes the vehicle after it has been accelerated to the test speed and so that any end stops on the guidance system do not interfere with its interaction with the vehicle. See Figure 29.
- 3.9.11.4.10 Fire the propulsion system to commence the test.

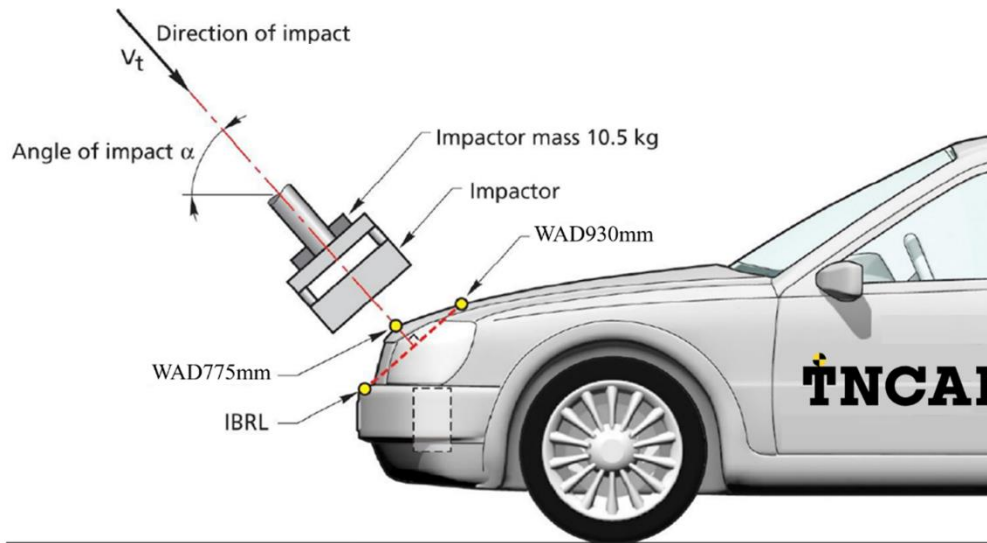

Figure 29: Upper Legform to WAD775mm Test

### 3.9.11.5 Test Procedure - Post Test

3.9.11.5.1 Take at least two still photographs of the resultant dent, one from the side and one from the front. Each photograph shall have some means of identifying the vehicle and test location. The preferred method shall be to use unique run numbers for each test.

3.9.11.5.2 Additional photographs may be required for an individual test at TNCAP discretion.

3.9.11.5.3 Check that no CAC has been exceeded before conducting the next test, if this has occurred then the impactor must be re-certified before the next test.

3.9.11.5.4 Replace any damaged part of the vehicle which would affect the results of the next test with new parts according to Section 3.9.8.3.

3.9.11.5.5 Repeat procedure for the next impact location.

### 3.9.12 Headform Testing

#### 3.9.12.1 Description of Headforms and Their Instrumentation

3.9.12.1.1 The headforms used shall conform to that specified in UN Regulation No. 127 Revision 2, Annex 4.

3.9.12.1.2 The child/small adult impactor to be used is defined in UN Regulation No. 127 Revision 2, Annex 4, Chapters 5.1 and 5.2. The adult impactor to be used is defined in UN Regulation No. 127 Revision 2, Annex 4, Chapters 5.3 and 5.4.

#### 3.9.12.1.3 Instrumentation:

Location	Measurement	CFC	CAC	No. of Channels
Centre of gravity of	Fore/Aft acceleration <sup>1</sup>	1000	500g	1

headform				
Centre of gravity of headform	Vertical acceleration	1000	500g	1
Centre of gravity of headform	Lateral acceleration	1000	500g	1

Note 1: Relative to the direction of motion of the headform

### 3.9.12.2 Certification - Dynamic

3.9.12.2.1 The certification procedures are detailed in Regulation UN Regulation No. 127 Revision 2, Annex 6, Chapter 3.

3.9.12.2.2 The headforms shall be certified after a maximum of 20 impacts and at least once every 12 months.

3.9.12.2.3 If the headforms exceed any of their lower performance limits then they shall be re-certified.

### 3.9.12.3 Test Procedure - Pre-Test

3.9.12.3.1 Ensure that the vehicle is fully test prepared as described in Section 3.9.1.

3.9.12.3.2 Ensure the vehicle is at the same ride heights as those recorded during marking up of the vehicle.

3.9.12.3.3 Ensure that the headforms, the vehicle, the propulsion system and the data acquisition equipment have soaked in a temperature in the range of 16°C to 24°C for at least 2 hours prior to testing.

3.9.12.3.4 Fit the required headform to the propulsion system. A child/small adult headform impactor shall be used for tests to the forward section of the bonnet top, A-pillars, windscreen, roof (labelled C in Section 3.9.3.10), with the test locations lying between boundaries described by wrap around distances of 1000mm and 1500mm. An adult headform impactor shall be used for tests to the rearward section of the bonnet top (labelled A in Section 3.9.3.10), with the test locations lying between boundaries described by wrap around distances of 1700 mm and 2100 mm. Where test locations lie between 1500 mm and 1700 mm the structure being tested will determine the headform to be used, see Section 3.9.3.5.9.

3.9.12.3.5 The position of the 'test location' describes the location of the grid point and will always determine which impactor shall be used; this will also be the case where the grid point is not coincidental with the point of first contact. For example, between 1500 mm and 1700 mm a grid point on the windscreen base will be impacted by the adult headform even if the point of first contact is with the rear edge of the bonnet.

- 3.9.12.3.6 Roll the vehicle forwards to give the desired free flight distance.
- 3.9.12.3.7 Adjust the propulsion system so that it can fire the headform at the grid point with the correct angle of incidence and is aimed at the impact point.
- 3.9.12.3.8 The direction of impact shall be in the fore and aft vertical plane of the section of the vehicle to be tested. The tolerance for this direction is  $\pm 2^\circ$ . The direction of impact of tests to the bonnet top shall be downward and rearward, as if the vehicle were on the ground.
- 3.9.12.3.9 The angle of impact for tests with the child/small adult headform impactor shall be  $50^\circ \pm 2^\circ$  to the Ground Reference Level. For all headform grid points on or forward of the bonnet leading edge reference line, defined in Section 3.9.3.3, the angle of impact shall be  $20^\circ \pm 2^\circ$  to the Ground Reference Level.
- 3.9.12.3.10 For tests with the adult headform impactor the angle of impact shall always be  $65^\circ \pm 2^\circ$  to the Ground Reference Level. For tests with the adult headform impactor to heavy vehicles, the angle of impact shall always be  $50^\circ \pm 2^\circ$  to the Ground Reference Level. Heavy vehicles are defined as vehicles meeting the following criteria:
- (1) M1 category
  - (2) Maximum Mass (Gross Vehicle Weight)  $> 2500\text{kg}$  and  $< 3500\text{kg}$
  - (3) 8 or 9 seats, including the driver's seat
  - (4) Derived from commercial vehicle
- 3.9.12.3.11 The effect of gravity shall be taken into account when the impact angle is obtained from measurements taken before the time of first contact.
- 3.9.12.3.12 The centreline of the headform impactor shall be within a  $\pm 10\text{mm}$  tolerance to the selected grid point.
- 3.9.12.3.13 Set the speed control on the propulsion system to give a velocity of  $11.1 \pm 0.2\text{m/s}$  at the point of first contact. The velocity measuring device shall be able to measure to an accuracy of at least  $\pm 0.02\text{ m/s}$ . The effect of gravity shall be taken into account when the impact velocity is obtained from measurements taken before the point of first contact.
- 3.9.12.3.14 Fire the propulsion system to commence the test.
- 3.9.12.4 Test Procedure - Post Test
- 3.9.12.4.1 Take at least two still photographs of the resultant dent, one from the side and one from the front. Each photograph shall have some means of identifying the vehicle and test location. The preferred method shall be to use unique run numbers for each test.
- 3.9.12.4.2 Additional photographs may be required for an individual test at TNCAP discretion.

3.9.12.4.3 Check that no CAC has been exceeded before conducting the next test, if this has occurred then the impactor must be re-certified before the next test.

3.9.12.4.4 Replace any damaged part of the vehicle which would affect the results of the next test with new parts according to Section 3.9.8.3.

3.9.12.4.5 Repeat procedure for the next impact location.

### 3.9.13 Glossary of Terms

3.9.13.1 Dynamic pedestrian tests - Synchronization of the headform propulsion device and system deployment to achieve correct head impact time.

3.9.13.2 Static pedestrian tests - Test to be carried out without the need to trigger the bonnet in due time. Bonnet is deployed and maintained in place with appropriate systems recommended by vehicle manufacturer.

3.9.13.3 Locking devices - systems that reach and remain in the intended position before head impact.

3.9.13.4 Non locking devices - systems that do not remain in a permanent deployed position or systems that do not reach the intended position before head impact.

3.9.13.5 Initiate deployment - Initiation of deployment means that there must be visible movement of the deployable component, such as the bonnet top. The signal sent from the ECU to the deployable components alone is NOT considered as 'initiation of deployment'.